

Series 270XT Freeze Protection Thermostats

Introduction

These controls are designed for protection against freeze-up of hydronic heating coils, cooling coils and similar application.

Description

Sensing element is 3 or 6 meters long to permit attaching across the surface of a coil to guard against freezing at any point. When any 30 cm or more of this element senses a temperature as low as the control setpoint, it will "switch off".

A special version is available with bulb and 2 m capillary, range -24/+18°C for clamp-on or immersion purposes.

SPDT change over contacts permit the use of an alarm signal.

Note

These controls are designed for use only as operating controls. Where an operating control failure would result in personal injury or loss of property it is the responsibility of the installer to add devices or systems that protect against, or warn of, control failure.



270XT-95008
 (with 6 m 'wrap-around' capillary)

Feature and Benefits

<input type="checkbox"/> Dust tight Pennswitch	Prevent pollution of the contacts by electrostatic influences
<input type="checkbox"/> SPDT contacts	Change-over contacts permits the use of an alarm signal
<input type="checkbox"/> 270XTAN provided with trip-free manual reset	Safety lock-out, override is not possible in the control function
<input type="checkbox"/> Controls have adjustable range	Suitable for several applications

Mounting

The control can be wall mounted either by using two screws through the holes in the back of the case or using the standard mounting bracket. The control must be mounted in that position where the sensing element is downside the control.

Note

The control should be installed where the ambient temperature surrounding the case and bellows is always higher than the control setting. If the ambient temperature around the enclosure drops below the control setting the bellows rather than the sensing element will operate the control.

Adjustment

The controls have a field adjustable setting and a fixed differential. A low limit stop, factory setting at 3 °C can be supplied at additional cost for quantity orders only.

Contact functions

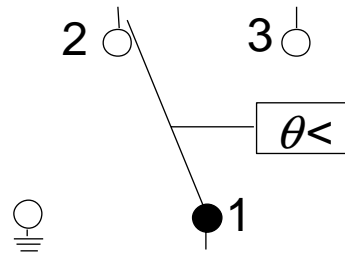

Fig. 1

1-2 open on temperature decrease

Repair and replacement

Repair is not possible. In case of an improperly functioning control, please check with your nearest supplier. When contacting the supplier for a replacement you should state the type/model number of the control. This number can be found on the data plate or cover label.

Type number selection table

Range °C	Diff. °C	Bulb and capillary	Bulb well no (not incl.)	Sensing element	Max. bulb temp. °C	Order number
-10 to +12	3 fixed	3 m cap. style 9**	-	3.2 mm x 3 m	200	270XT-95078
-10 to +12	manual reset	3 m cap. style 9**	-	3.2 mm x 3 m	200	270XTAN-95088
-10 to +12	3 fixed	6 m cap. style 9**	-	3.2 mm x 6 m	200	270XT-95008
-10 to +12	manual reset	6 m cap. style 9**	-	3.2 mm x 6 m	200	270XTAN-95008
-24 to +18	4 fixed	2 m cap. style 1*	WEL14A602R	9.5 x 77 mm bulb and 2 m cap.	120	270XT-95068
-24 to +18	manual reset	2 m cap. style 1*	WEL14A602R	9.5 x 77 mm bulb and 2 m cap.	120	270XTAN-95048

* With 7.5 cm bulb support to apply packing nut FTG13A-600 for direct immersion applications.

** With 6 m "wrap-around" capillary, when any 30 cm or more of this element senses a temperature as low as the cut-out point, the contact will open.

Optional accessories (for 270XT and 270XTAN, with "wrap-around" cap.

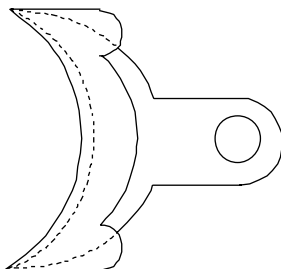

Fig. 2

Bracket:

Order number KIT012N600 (6 pcs)

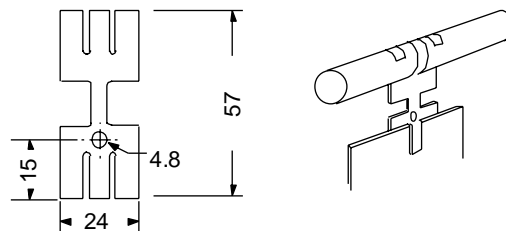
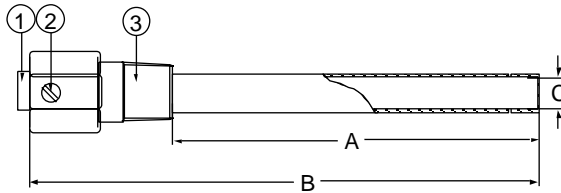

Fig. 3

Mounting clip:

Order number T-275-101

Optional accessories (for 270XT and 270XTAN with 2 m capillary and bulb)



Order no.	DIM. 'A'	DIM. 'B'	DIM. 'C' Internal
WEL14A602R	125 mm	171 mm	10mm

Fig. 4
Bulb well

1. Bushing
2. Set screw
3. Adapter, 1/2" - 14 NPT

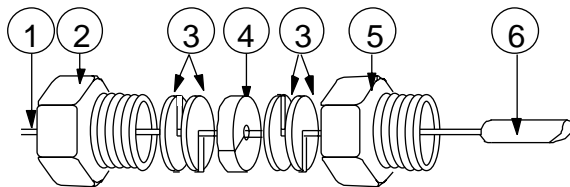

1. Style 1b bulb support tube
2. Packing nut
3. Washer
4. Packing
5. Adapter, 1/2" - 14 NPT
6. Bulb

Fig. 5
Closed-tank-connector
Order number **FTG13A-600R**

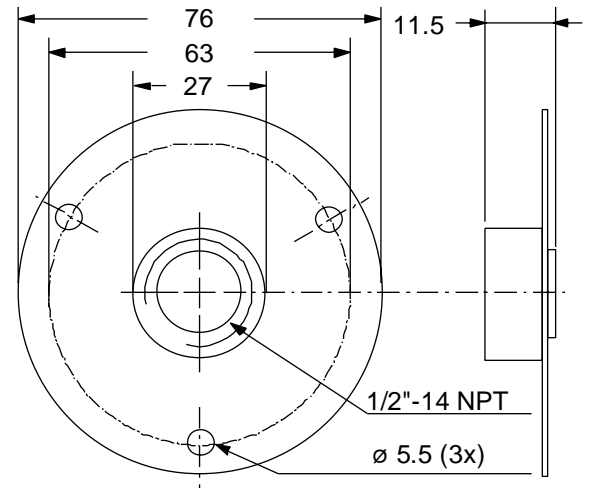

Fig. 6
Duct flange
Order number **T-752-1001**

Dimensions (mm)

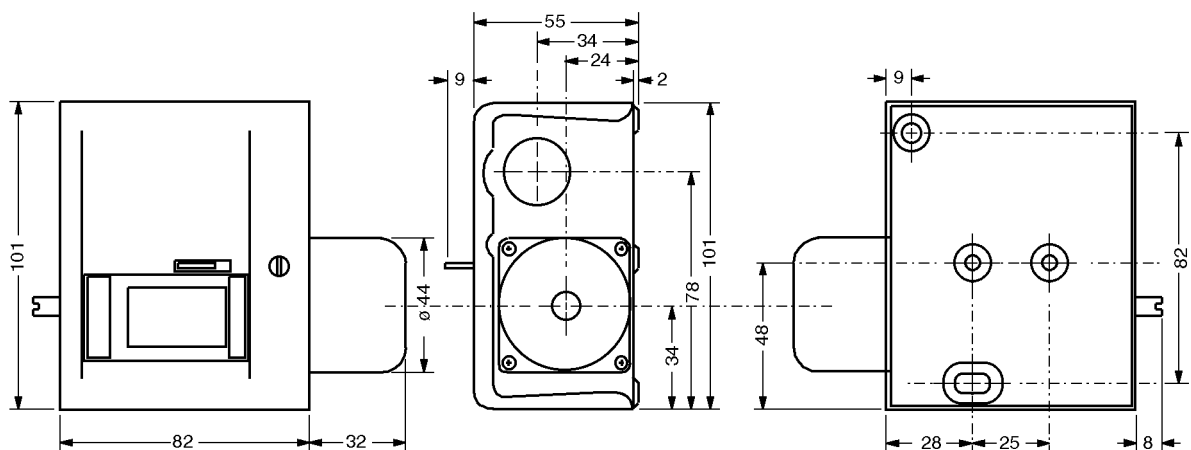

Fig. 7

Specifications

Product type	270XT / 270XTAN		
Operating range	-24 to + 18 °C (refer to type number selection table)		
Differential	fixed (refer to type number selection table)		
Range adjustment	Screwdriver, external scale		
Electrical rating	~15(8)A, 230V		
Contact function	SPDT		
CE Conformity	According to low voltage directive and EMC directive		
Max. ambient temperature	55 °C Note: The operating ambient temperature of the control should always be higher than the sensing element temperature		
Material	Case	Cold-rolled zinc plated steel	
	Cover	blue coloured cold-rolled steel	
Enclosure (protection class)	IP30		
Dimensions (HxWxD)	82 x 101 x 53 mm (excl. bellows)		
Shipping weight	Individual pack standard		
Ind. pack	270XT-95078/270XTAN-95088	1.00 Kg	
	270XT-95008/270XTAN-95008	1.15 Kg	
	270XT-95068/270XTAN-95048	0.9 Kg	
Overpack	270XT-95078/270XTAN-95088	13	Kg (13 pcs.)
	270XT-95008/270XTAN-95008	15	Kg (13 pcs.)
	270XT-95068/270XTAN-95048	12	Kg (13 pcs.)

The performance specifications are nominal and conform to acceptable industry standards. For applications at conditions beyond these specifications, consult the local Johnson Controls office or representative. Johnson Controls shall not be liable for damages resulting from misapplication or misuse of its products.



Johnson Controls International, Inc.

Headquarters: Milwaukee, Wisconsin, USA
 European Customer Service Center: Westendhof 3, D-45143 Essen, Germany
 European Factories: Essen (Germany), Leeuwarden (The Netherlands) and Lomagna (Italy)
 Branch Offices: Principal European Cities.
 This document is subject to change

Printed in Europe

Series A19A/A19B/A19D

Thermostats for Refrigeration, Cooling, Heating, Ventilation and Air-conditioning

Introduction

These thermostats are designed for refrigeration, cooling, heating, ventilation and air-conditioning applications. Standard models are provided for remote sensing or room sensing. Models with manual reset are available for low or high limit functions.

Description

These thermostats are available with fixed or adjustable differential. The various control ranges cover a broad range of temperature applications with a minimum number of models. On request a built-in high or low limit stop is possible and can be adjusted quickly and easily in the field. All models have a universal way of adjustment. For this purpose a knob and sealing cap are enclosed.

All A19 style 1 wholesaler code models have a bulb clamp plus screw also enclosed.



A19A capillary thermostat
A19B space thermostat

Feature and Benefits

<input type="checkbox"/> Liquid filled sensing element	No cross ambient temperature problems Contact differential over the whole range
<input type="checkbox"/> Dust tight Penn switch	Prevents pollution of the contacts by electrostatic influences.
<input type="checkbox"/> Trip free manual reset	Override is not possible in the control function
<input type="checkbox"/> Front adjustment	Less mounting space required.

Note

These controls are designed for use only as operating controls. Where an operating control failure would result in personal injury or loss of property it is the responsibility of the installer to add devices or systems that protect against, or warn of, control failure.

SPDT contacts are standard on all models. Instruments have compact sizes. Types A19ACC and A19ADC have a trip-free manual reset. Reset button must be pressed and released. Contact cannot be blocked in closed position. All types have VDE and SEV approval.

To facilitate ordering, wholesaler codes have been added on some universal models. All models are provided with a separate knob and sealing cap.

Type number matrix

- A19AAC** capillary thermostat, fixed differential.
- A19AAF** capillary thermostat, special close fixed differential.
- A19ABC** capillary or immersion thermostat, adjustable differential.
- A19ACC** capillary thermostat, lock-out low with manual reset.
- A19ADC** immersion thermostat, lock-out high with manual reset.
- A19BAC** space thermostat, fixed differential.
- A19BBC** space thermostat, adjustable differential.
- A19DAC** strap-on thermostat.
- A19DAF** strap-on thermostat

Adjustment

1. Models "set low" (refer to cover label)
The dial indicates the low switch point (1 - 2 open, 1 - 3 closed).
The high switch point (1 - 2 closed, 1 - 3 open) is obtained by adding the differential to the low switch point.
2. Models "set high" (refer to cover label)
The dial indicates the high switch point (1 - 2 closed, 1 - 3 open). The low switch point (1 - 2 open, 1 - 3 closed) is obtained by deducting the differential from the high switch point.

Exception: Type A19ADC, dial indicates high switch point (1 - 3 closed, 1 - 2 open).

Note

The standard screwdriver adjustment can be converted easily in the field to knob adjustment. Also concealing of adjustment and scale is possible after installation.

Contact functions

Types A19AAC, A19AAF, A19ABC, A19BAC, A19BBC, A19DAC

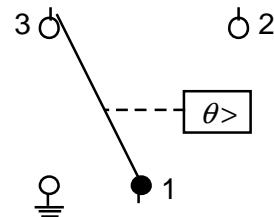

Fig. 1

1-2 closes on temperature increase

Type A19ACC

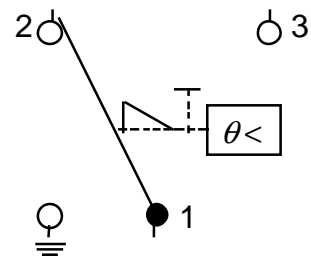

Fig. 2

1-2 opens on temperature decrease

Type A19ADC

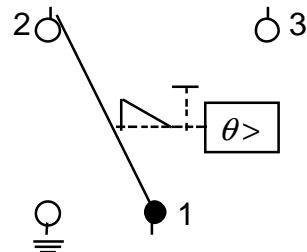

Fig.3

1-2 opens on temperature increase

Repair and replacement

Repair is not possible. In case of an improperly functioning control, please check with your nearest supplier. When contacting the supplier for a replacement you should state the type/model number of the control. This number can be found on the data plate or cover label.

Sensor styles

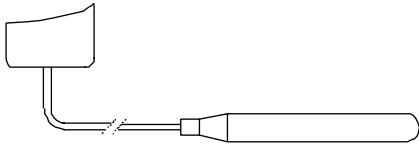

Fig. 4
Style 1a (drawn bulb)

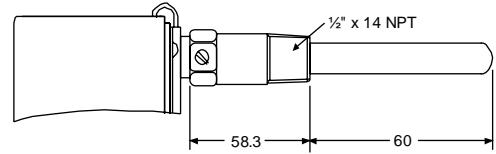

Fig. 7
Style 2

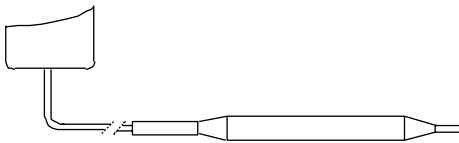

Fig. 5
Style 1b swaged bulb, can be used with closed-tank connector FTG13A-600

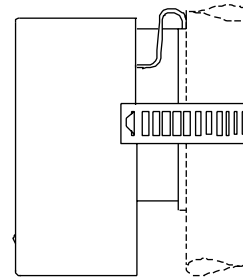

Fig. 8
Style 20

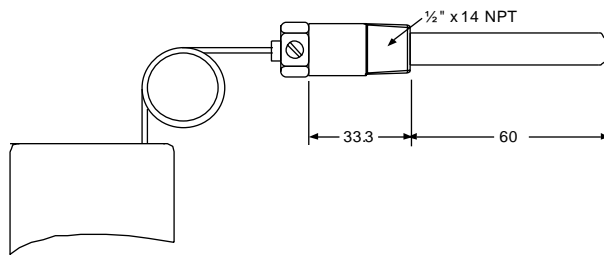

Fig. 6
Style 4h

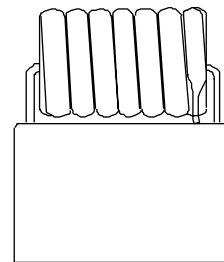

Fig. 9
Style 3 (coil)

Bulb size and finish, bulb wells

Range (°C)	Style	Bulb size (mm)	Finish	Bulb well (optional)
-35 to +10	1b	9.5 x 110	Tin-plated	WEL14A602R
-35 to +10	3	-	Stainless Steel	-
-5 to +28	1b	9.5 x 135	Tin-plated	WEL14A603R
-5 to +28	3	-	Stainless Steel	-
-35 to +40	1b	9.5 x 110	Tin-plated	WEL14A602R
-35 to +40	3	-	Stainless Steel	-
0 to 13	1a	9.3 x 80	-	WEL16A601R
0 to 43	3	-	Stainless Steel	-
1 to 60	1b	9.5 x 115	-	WEL14A602R
5 to 32	1b	9.5 x 155	Tin-plated	No bulb well available
10 to 95	1a	7.4 x 75	-	WEL11A601R
40 to 120	1b	9.5 x 100	-	WEL14A602R
35 to 150	1a	5 x 265	-	No bulb well or closed tank connector possible
90 to 290	1a	5 x 155	-	No bulb well or closed tank connector possible

Type number selection table:

Range (°C)	Diff. (K)	Bulb style	Setting (see page 2 adjustment)	Cap. length	Max. bulb temp.	Wholesaler code	Order number
------------	-----------	------------	---------------------------------	-------------	-----------------	-----------------	--------------

Type A19AAC Capillary thermostat, fixed differential

-35 to +10	2.5	1b	set low	2 m	60 °C		A19AAC-9102
-5 to +28	2	1b	set low	2 m	60 °C		A19AAC-9005
-5 to +28	2	1b	set low	5 m	60 °C		A19AAC-9124
1 to 60	2	1b	set low	3 m	85 °C		A19AAC-9127
40 to 120	3.5	1b	set high	2 m	145 °C		A19AAC-9009
35 to 150	4	1a	set high	2 m	180 °C		A19AAC-9107
90 to 290	5.5	1a	set high	2 m	290 °C		A19AAC-9108

Type A19ABC Capillary or immersion thermostat, adjustable differential

-35 to +40	2.8 to 8	1b	set low	3.5 m	60 °C	A19-A4	A19ABC-9037
-35 to +40	2.8 to 8	1b	set low	6.5 m	60 °C	A19-A5	A19ABC-9036
-35 to +10	2.8 to 11	1b	set low	2 m	60 °C	A19-A1	A19ABC-9103
-5 to +28	2 to 8	1b	set low	2 m	60 °C	A19-A2	A19ABC-9104
1 to 60	2 to 8	1b	set low	5 m	85 °C		A19ABC-9117
1 to 60	2 to 8	1b	set low	3 m	85 °C	A19-A3	A19ABC-9116
10 to 95	3.5 to 13	1a	set high	3.5 m	115 °C		A19ABC-9106
40 to 120	3.5 to 13	2	set high	-	145 °C		A19ABC-9011 bulb well incl.
40 to 120	3.5 to 13	4h	set high	2 m	145 °C		A19ABC-9012 bulb well incl.

Type A19ACC Capillary thermostat, lock-out low with manual reset

-35 to +10	6 ↘	1b	set low	2 m	60 °C		A19ACC-9100
-35 to +10 ✖	6 ↘	1b	set low	3.5 m	60 °C		A19ACC-9105
-35 to +10 ✖	6 ↘	1b	set low	5 m	60 °C		A19ACC-9111
-35 to +10 ✖	6 ↘	1b	set low	6.5 m	60 °C	A19-F	A19ACC-9116
-5 to +28	4 ↘	1b	set low	2 m	60 °C		A19ACC-9101
-5 to +28	4 ↘	1b	set low	5 m	60 °C		A19ACC-9103
-5 to +28	4 ↘	1b	set low	3 m	60 °C		A19ACC-9107

Type A19ADC immersion thermostat, lock-out high with manual reset

40 to 120	7 †	2	set high	-	145 °C		A19ADC-9200 bulb well incl.
-----------	-----	---	----------	---	--------	--	---------------------------------------

Type A19AAF Capillary thermostat, close, fixed differential

0 to 10	1.5	1a	set low	2 m	80 °C		A19AAF-9101
0 to 10	1.5	1a	set low	2 m	80 °C	A19-M ‡	A19AAF-9102
5 to 32	0.75	1b	set high	2 m	60 °C		A19AAF-9103

↘ Indicates temperature increase above cut-out point to make reset possible.

✖ Low limit stop factory set +2.5 °C may be removed in the field.

† Indicates temperature decrease below cut-out point to make reset possible.

‡ Milk-cooler thermostat.

***T*ype number selection table:**

Range (°C)	Diff. (K)	Bulb style	Setting (see page 2 adjustment)	Cap. length	Max. bulb temp.	Wholesaler code	Order number
-------------	-----------	------------	---------------------------------	-------------	-----------------	-----------------	--------------

Type A19BAC Space thermostat, fixed differential

-35 to +10	2.5	3	set low	-	60 °C	A19-B1	A19BAC-9250
-5 to +28	2	3	set low	-	60 °C	A19-B2	A19BAC-9251
0 to 43	2	3	set high	-	60 °C	A19-B3	A19BAC-9001

Type A19BBC Space thermostat, adjustable differential

-35 to +40	2.8/8	3	set low	-	60 °C	A19-B4	A19BBC-9275
------------	--------------	---	---------	---	-------	--------	--------------------

Type A19DAC, Strap-on thermostat, fixed differential

40 to 120	4.5	20	set high	-	145°C		A19DAC-9001
92 to 116	2	20	set high	-	145°C		A19DAF-9001

Note: If what you need is not in the type number selection table, then please contact your representative.

Accessories (optional)

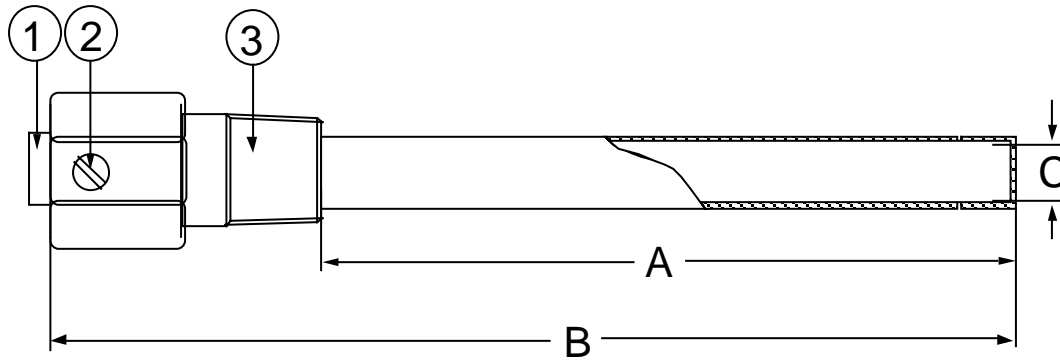

Order no.	Dimension A	Dimension B	Dimension C Internal
WEL11A601R	60 mm	118 mm	7.3 mm
WEL14A602R	125 mm	171 mm	9.8 mm
WEL14A603R	147 mm	193 mm	9.8 mm
WEL16A601R	71 mm	117 mm	9.5 mm

1. Bushing
2. Set screw
3. Adapter, 1/2"-14 NPT

Fig. 10
Bulb well (brass, copper pipe)

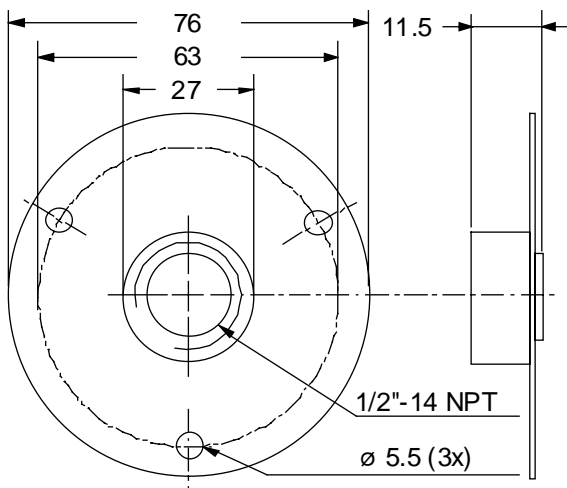
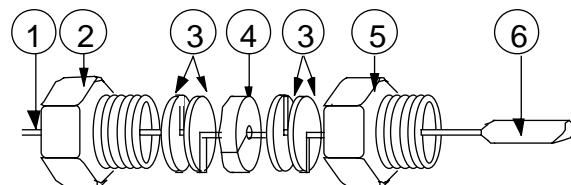

Fig. 11
Duct flange to be used with closed-tank connector FTG13A-600R.
Order number T-752-1001



1. Style 1b bulb support tube
2. Packing nut
3. Washer
4. Packing
5. Adapter, 1/2"-14 NPT
6. Bulb

Fig. 12
Closed-tank connector
Order number FTG13A-600R

Specifications

CE Conformity	According to low voltage directive and EMC directive	
Operating range	-35 to +290 °C. See type number selection table.	
Differential	See type number selection table.	
Differential adjustments	Controls with adjustable differential (types A19ABC and A19BBC) have an adjustment lever under the cover.	
Sensor styles	Styles 1a, 1b, 2, 3, 4h, and 20 (see drawings page 3)	
Electrical ratings	~15(8) A, 230 V; except A19AAF and A19DAF: ~15(3) A 230 V, and A19ABC-9036/9037: ~15(5) A 230 V	
Ambient temp. limits	-35 to +55 °C	
Conduit opening	22.3 mm diam. hole for PG-16 connector	
Material	Case	1.75 mm cold-rolled zinc plated steel
	Cover	1.5 mm ABS plastic
Protection Class	IP30	
Shipping weight	Individual pack	0.4 kg
	Overpack	10 kg (24 pcs)
Dimensions	(see dimension drawing)	

The performance specifications are nominal and conform to acceptable industry standards. For applications at conditions beyond these specifications, consult the local Johnson Controls office or representative. Johnson Controls shall not be liable for damages resulting from misapplication or misuse of its products.



Johnson Controls International, Inc.

Headquarters: Milwaukee, WI, USA
 European Headquarters: Westendhof 8, 45143 Essen, Germany
 European Factories: Lomagna (Italy), Leeuwarden (The Netherlands) and Essen (Germany)
 Branch Offices: Principal European Cities.

This document is subject to change

Printed in Europe

Series A19ARC/BRC/AQC/AQF/BQC Thermostats Splash-proof and Dust-tight Enclosure

Introduction

These thermostats are designed for applications where a splash-proof and/or dust-tight enclosure is required. Four types are available.

- Types A19ARC are general purpose capillary thermostats.
- Types A19BRC and A19BQC are space thermostats with coiled element to be used as farm control, outdoor thermostats or in cold storage rooms.
- Types A19AQF is specially designed for milkcool-tank applications.
- Type A19AQC-9101 is specially designed for ice-bank application.

Description

These thermostats are available with fixed or adjustable differential. The various control ranges cover a broad range of temperature applications with a minimum number of models. SPDT contacts are standard on all models.

Note: To facilitate ordering wholesaler codes have been added on some universal models.



A19ARC
Thermostat with style 1b bulb

Feature and Benefits

<input type="checkbox"/> Liquid filled sensing element	No cross ambient temperature problems Contact differential over the whole range
<input type="checkbox"/> Dust tight Penn switch	Prevents pollution of the contacts by electrostatic influences.
<input type="checkbox"/> IP65 protection class	Suitable for outdoor applications
<input type="checkbox"/> Front adjustment	Less mounting space required.

Note

These controls are designed for use only as operating controls. Where an operating control failure would result in personal injury or loss of property it is the responsibility of the installer to add devices or systems that protect against, or warn of, control failure.

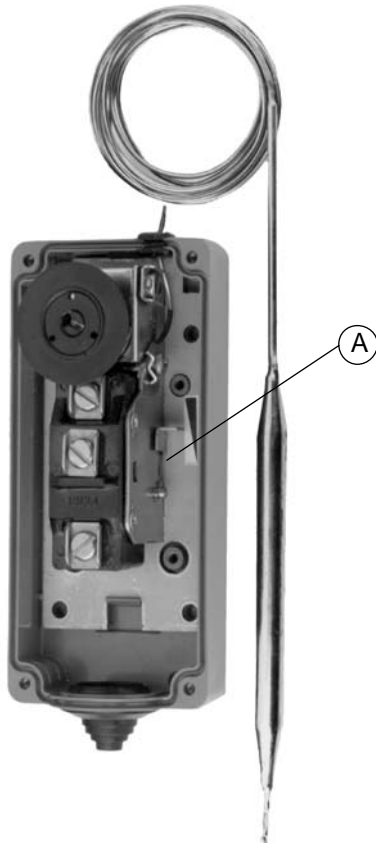

Fig.1
Thermostat A19ARC, cover removed
A Differential adjustment lever.

Adjustment

The dial set point indicates the low switch point (1 - 2 open, 1 - 3 closed). The high switch point (1 - 2 closed, 1 - 3 open) is obtained by adding the differential to the low switch point. Adjustable differential models can be adjusted by means of the differential adjustment lever (A). (See Fig.1)

Contact functions

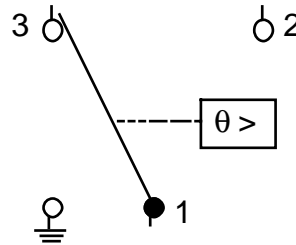

Fig.2
1-2 closes on temperature increase

Repair and replacement

Repair is not possible. In case of an improperly functioning control, please check with your nearest supplier. When contacting the supplier for a replacement you should state the type/model number of the control. This number can be found on the data plate or cover label.

Sensor styles

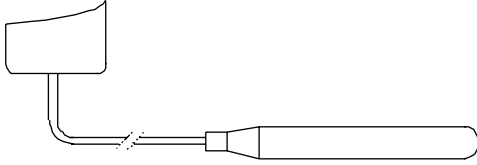

Fig. 3
Style 1a (drawn bulb)

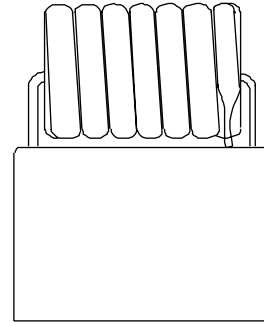

Fig. 5
Style 3 (coil)

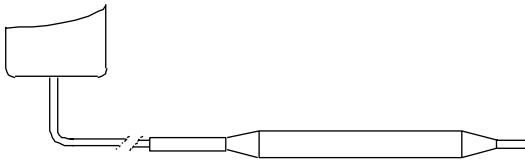

Fig. 4
**Style 1b swaged bulb, can be used with
closed-tank connector FTG13A-600R**

Bulb size and finish, bulb wells

Range (°C)	Style	Bulb size (mm)	Finish	Bulb well (optional)
-35 to +10	1b	9.5 x 110	Tin-plated	WEL14A602R
-35 to +10	3	-	Stainless Steel	-
-35 to +40	1b	9.5 x 135	Tin-plated	WEL14A602R
-35 to +40	3	-	Stainless Steel	-
-20 to +65	1a	7.4 x 75	-	WEL11A601R
-10 to +50	1b	9.5 x 110	-	WEL14A602R
- 5 to +5	1a	9.3 x 80	-	WEL16A601R
- 5 to +28	1b	9.5 x 135	Tin-plated	WEL14A603R
- 5 to +28	3	-	Stainless Steel	-
0 to 43	3	-	Stainless Steel	-
1 to 60	1b	9.5 x 115	-	WEL14A602R
5 to 50	1	10.5 x 110	Neoprene coated	-
0 to 10	1a	9.3 x 80	-	WEL16A601R
40 to 120	1b	9.5 x 110	-	WEL14A602R

Type number selection table:

Range (°C)	Diff. (K)	Bulb style	Cap. length	Max. bulb temp.	Wholesaler code	Order number
-------------	-----------	------------	-------------	-----------------	-----------------	--------------

Type A19ARC Capillary thermostat, adjustable differential, knob adjustment

-35 to +10	2.8 to 11	1b	2 m	60 °C	A19-AS1	A19ARC-9100
-35 to +40	2.8 to 11	1b	2 m	60 °C	A19-AS4	A19ARC-9113
-20 to +65	3.5 to 13	1a	3.5 m	85°C		A19ARC-9104
-5 to +28	2 to 8	1b	2 m	60°C	A19-AS2	A19ARC-9101
1 to 60	2 to 8	1b	3 m	85°C	A19-AS3	A19ARC-9109
40 to 120	3.5 to 13	1b	2 m	143°C		A19ARC-9107

Type A19ARC Capillary thermostat, adjustable differential, concealed adjustment

-10 to +50	2.5 to 11	1b	2m	80°C		A19ARC-9110
40 to 120	3.5 to 13.5	1b	2m	143°C		A19ARC-9112

Cooling tower thermostat, neoprene coated bulb and capillary, concealed adjustment

5 to 50	2.5 to 11	1	2 m	100°C		A19ARC-9105
---------	-----------	---	-----	-------	--	--------------------

Cooling tower thermostat, concealed adjustment fixed differential

-5 to +55	2.5	2	-	85 °C	A19-A3	A19AQC-9200
-----------	-----	---	---	-------	--------	--------------------

A19AQC Ice bank thermostat, case compensation, concealed adjustment, fixed differential

-5 to +5	2	1a	2 m	80°C		A19AQC-9101
----------	---	----	-----	------	--	--------------------

A19AQC capillary thermostat, fixed differential, knob adjustment

-5 to +28	2	1b	2 m	60 °C		A19AQC-9102
-----------	---	----	-----	-------	--	--------------------

Type A19AQF Milkcool thermostat, small fixed differential, concealed adjustment, case compensation

0 to 13	1.5	1a	2 m	80°C		A19AQF-9100
0 to 13	1.5	1a	3 m	80°C		A19AQF-9102

Type A19BRC Space thermostat, adjustable differential, knob adjustment

-35 to +10	2.8 to 11	3	-	60 °C	A19-BS1	A19BRC-9252
-35 to +40	2.8 to 11	3	-	60 °C	A19-BS4	A19BRC-9253
-5 to +28	2 to 8	3	-	60 °C	A19-BS2	A19BRC-9250
0 to 43	2 to 8	3	-	60 °C	A19-BS3	A19BRC-9251

Outdoor change-over thermostat, concealed adjustment. For bivalent heatpumps

-5 to +25	2	3	-	60°C		A19BQC-9252
-----------	---	---	---	------	--	--------------------

Note: If what you need is not in the type number selection table then please contact your representative.

Accessories (optional)

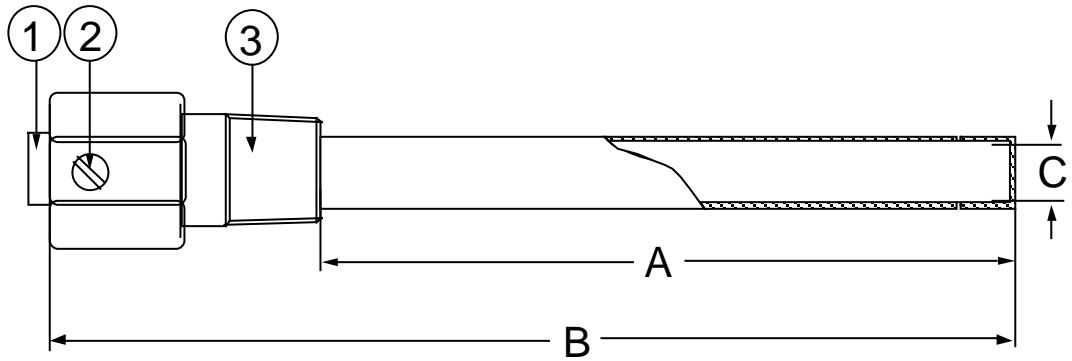

Order no.	Dimension A	Dimension B	Dimension C Internal
WEL11A601R	60 mm	118 mm	7.3 mm
WEL14A602R	125 mm	171 mm	9.8 mm
WEL14A603R	147 mm	193 mm	9.8 mm
WEL16A601R	71 mm	117 mm	9.5 mm

1. Bushing
2. Set screw
3. Adapter, 1/2"-14 NPT

Fig. 6
Bulb well (brass, copper pipe)

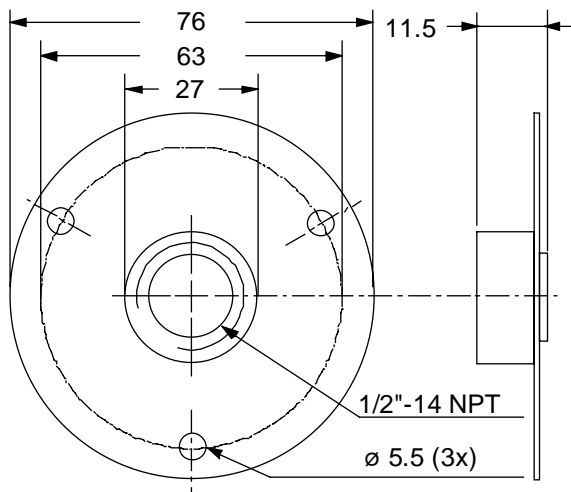
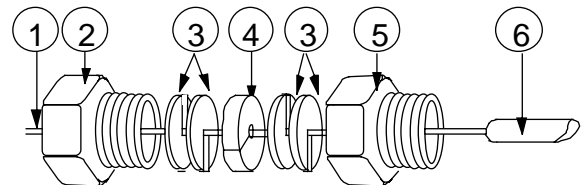

Fig. 7
Duct flange to be used with closed-tank
connector FTG13A-600RR.
Order number **T-752-1001**



1. Style 1b bulb support tube
2. Packing nut
3. Washer
4. Packing
5. Adapter, 1/2"-14 NPT
6. Bulb

Fig. 8
Closed-tank connector
Order number **FTG13A-600R**

Dimensions (mm)

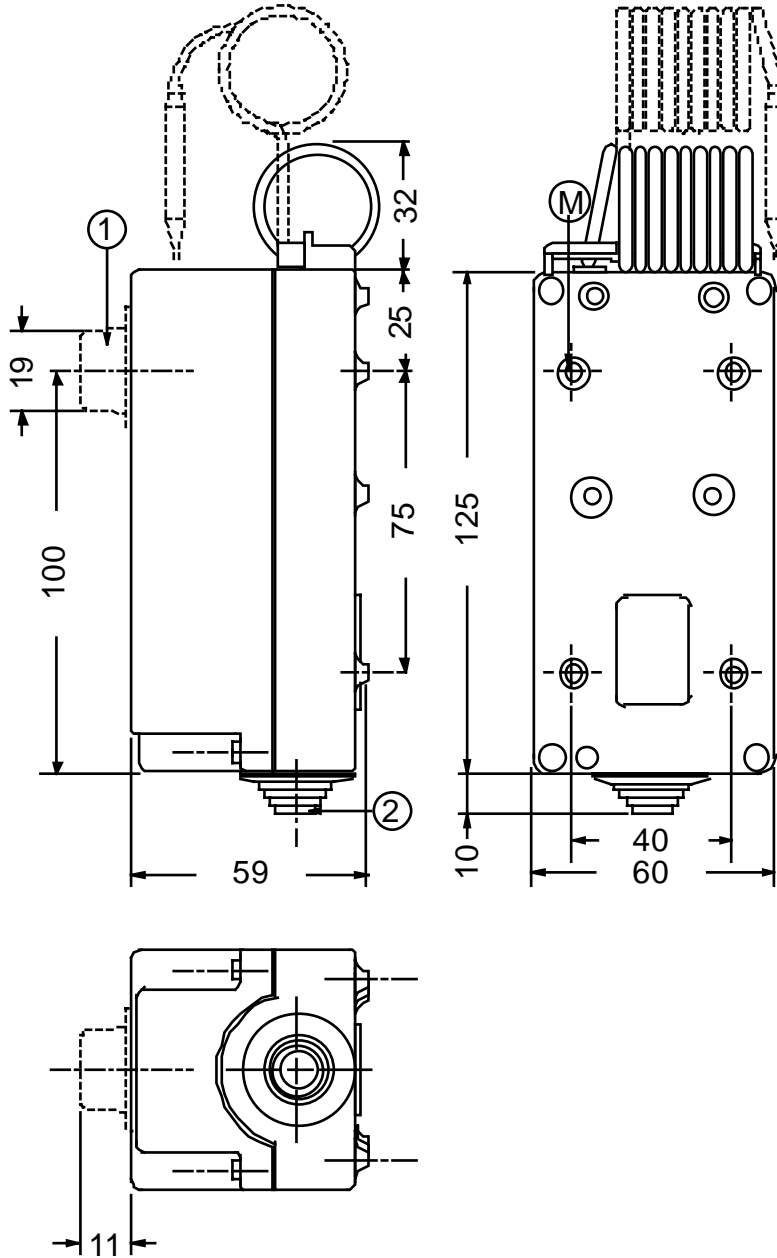

- 1 Knob (knob models only)
- 2 Cable grommet \varnothing 5 to \varnothing 13 mm
- M 4 Mounting holes \varnothing 4.5 mm use 2 holes only

Fig. 9

Dimensions (mm)

A19AQC-9200

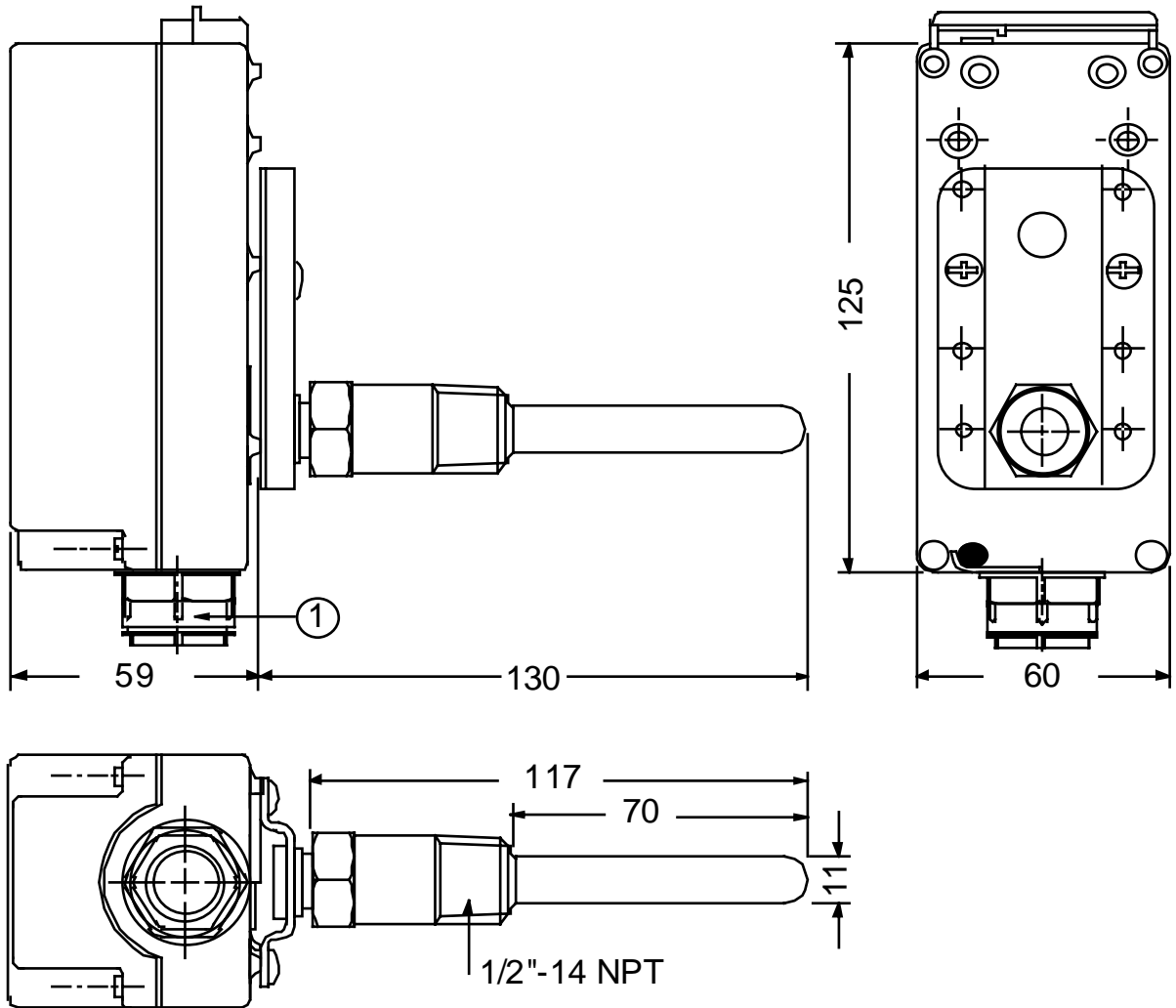

1 PG16 connector

Fig. 10

Specifications

CE Conformity	According to low voltage directive and EMC directive	
Operating range	-35 to +120 °C. See type number selection table.	
Differential	See type number selection table.	
Differential adjustments	Controls with adjustable differential (types A19ARC and A19BRC) have an adjustment lever under the cover	
Sensor styles	1a, 1b, 3 and 2 (see page 3)	
Electrical ratings	~15(8)A 230V; except A19AQC-9101 ~15(5)A 230V; A19AQF ~15(3)A 230V	
Ambient temp. limits	-35 to +55 °C	
Conduit connector	Cable grommet. Conduit opening also applicable for PG16 connector.	
Material	Case/Cover	Polycarbonate
Protection Class	Dust-tight, splash-proof IP65	
Shipping weight	Individual pack	0.5 kg
	Overpack	12 kg (24 pcs) (A19AQC-9200 =14 pcs.)
Dimensions	(see dimension drawing)	

The performance specifications are nominal and conform to acceptable industry standards. For applications at conditions beyond these specifications, consult the local Johnson Controls office or representative. Johnson Controls shall not be liable for damages resulting from misapplication or misuse of its products.

JOHNSON
CONTROLS

Johnson Controls International, Inc.

Headquarters: Milwaukee, WI, USA
 European Headquarters: Westendhof 8, 45143 Essen, Germany
 European Factories: Lomagna (Italy), Leeuwarden (The Netherlands) and Essen (Germany)
 Branch Offices: Principal European Cities.

This document is subject to change

Printed in Europe

Serie A25CN Limit Control Manual Reset

Introduction

These warm air limit controls "lock out" on a temperature increase to the control setpoint. Manual reset is required to re-close the electrical contacts. A typical application is to stop air-conditioning or ventilating fans in the event of excessive return air temperature, as from a fire.

Description

A rod and tube type sensing element actuates the switch contacts. Main contacts (1 - 2) are normally closed, and open when the temperature at the element rises to the dial setpoint. Contacts are re-closed only by operation of the reset lever. The reset lever is "trip-free" and cannot be used to block contacts in a closed position.

Location

Select a location in the duct or plenum where the temperature element senses the average temperature to be controlled and is in free air circulation.

Mounting

The instrument is mounted by means of the flange which is supplied with the control. The element is to be inserted in the duct and must be in the airstream as much as possible. It should not be in contact with any object inside the duct.

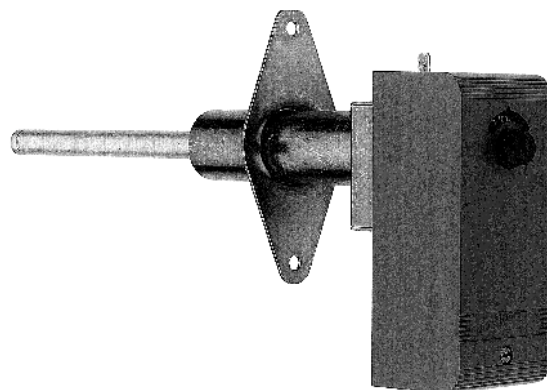

A25CN

Note

These controls are designed for use only as operating controls. Where an operating control failure would result in personal injury or loss of property it is the responsibility of the installer to add devices or systems that protect against, or warn of, control failure.

Adjustment

These thermostats are standard available with a knob adjustment. This knob can be removed in the field to provide screwdriver adjustment.

Feature and Benefits

<input type="checkbox"/> Rod and tube type of element	Gives maximum response Allows high maximum element temperature
<input type="checkbox"/> Adjustable duct mounting flange	Allows various lengths insertion of the element into the airstream
<input type="checkbox"/> Trip-free manual reset	Override is not possible in the control function
<input type="checkbox"/> Dust-tight Penn switch	Prevent pollution of the contacts by electromagnetic influences

Contact function

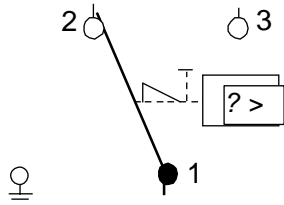

Fig. 1

1 - 2 opens on temperature increase.

Repair and replacement

Repair is not possible. In case of an improperly functioning control, please check with your nearest supplier. When contacting the supplier for a replacement you should state the type/model number of the control. This number can be found on the data plate or cover label.

Dimensions (mm)

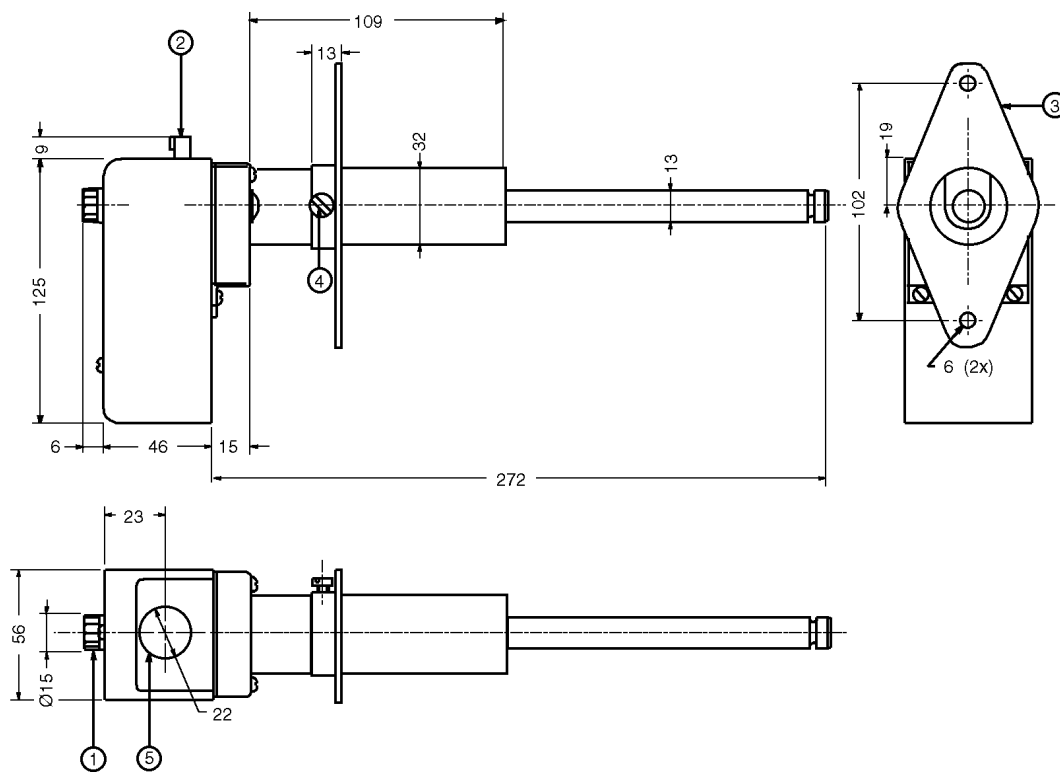

- 1 Dial knob
- 2 Reset lever
- 3 Flange
- 4 Set screw 1/4 "- 20 UNC
- 5 Ø 22.3 cable inlet hole for PG 16.

Notes

Specifications

Type number	A25CN-9001
CE Conformity	According to low voltage directive and EMC directive
Range	0 to 100 °C
Electrical rating	~15(8) A 230 V
Max. element temperature	150 °C
Max. case temperature	55 °C
Power element	Rod and tube construction
Reset	Positive, trip-free reset mechanism. Control can be reset when temperature drops 15 K below dial setting.
High limit dial stop	Adjustable (in steps) between 50 °C and 95 °C.
Shipping weight	Individual pack 0.9 kg Overpack 15 kg (16 pcs)
Enclosure (protection class)	IP30
Dimensions	(see dimension drawing)

The performance specifications are nominal and conform to acceptable industry standards. For applications at conditions beyond these specifications, consult the local Johnson Controls office or representative. Johnson Controls shall not be liable for damages resulting from misapplication or misuse of its products.



Johnson Controls International, Inc.

Headquarters: Milwaukee, WI, USA
 European Headquarters: Westendhof 8, 45143 Essen, Germany
 European Factories: Lomagna (Italy), Leeuwarden (The Netherlands) and Essen (Germany)
 Branch Offices: Principal European Cities.
 This document is subject to change

Printed in Europe

Series A28 Two stage Thermostats

Introduction

These thermostats are designed for various types of heating, cooling, ventilation, or air-conditioning applications. All models have two SPDT switches providing the following control possibilities:

- 2 stage heating
- 2 stage cooling
- heating/cooling with automatic changeover

Models are provided with a standard IP30 case or splashproof, dust-tight IP65 plastic case

Description

Controls are compact with fixed differential per stage and (on most models) adjustable differential between stages. Liquid filled element provides wide range, constant differential over whole range and no influence from barometric pressure. Since the bulb contains the major portion of the total fill the thermostat may be considered as cross-ambient, capillary and cup temperature variations affect the operating point only slightly due to the small amount of fill they contain.

For quantity orders it is possible to have the below stated optional constructions

- Without case and cover for panelmounting
- Close differential per stage
- Different capillary lengths

All standard IP30 enclosure models have a universal way of adjustment. For this purpose a knob and sealing cap are enclosed.



A28QA
splashproof dust-tight thermostat with 2m
capillary and style 1b bulb (left).

A28AA
thermostat with style 3 element (right).

Feature and Benefits

<input type="checkbox"/> Liquid filled sensing element	No cross ambient temperature problems Constant differential over the whole range
<input type="checkbox"/> Dust tight Penn switch	Prevents pollution of the contacts by electrostatic influences.
<input type="checkbox"/> IP65 protection class models available	Suitable for outdoor applications
<input type="checkbox"/> Front adjustment	Less mounting space required

Note

These controls are designed for use only as operating controls. Where an operating control failure would result in personal injury or loss of property it is the responsibility of the installer to add devices or systems that protect against, or warn of, control failure.

Adjustment

Models "set low" (see also cover label):
The dial indicates the switch point "SP1" (see switching diagram).

Models "set high" (see also cover label):
The dial indicates the switch point "SP2" (see switching diagram)

For IP30 models the standard screwdriver adjustment can be converted easily in the field to knob adjustment. Also concealing of adjustment is possible after installation.

Contact function

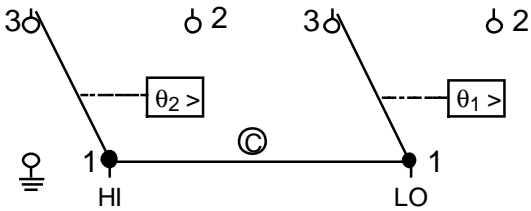

$$\theta_1 < \theta_2$$

Fig. 1
1-2 closes on temperature increase.
C Removable jumper.

Switching diagram (Heating Mode)

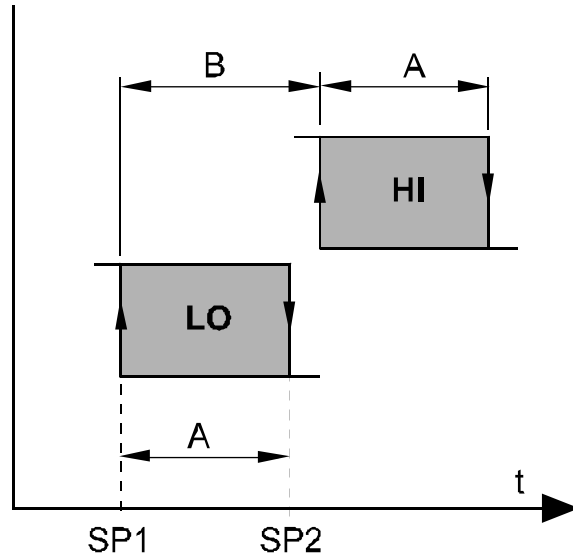

Fig.2

- A** Differential per stage.
- B** Differential between the stages.
- SP1** Dial setting (for exceptions see 'SP2').
- SP2** Dial setting (range 0 to 43°C and 1 to 60°C).
- t** Temperature increase.
- LO** Low stage.
- HI** High stage.

Repair and Replacement

Repair is not possible. In case of an improperly functioning control, please check with your nearest supplier. When contacting the supplier for a replacement you should state the type/model number of the control. This number can be found on the data plate or cover label.

Type number selection table:

Range (°C)	Diff. per stage (K)	Diff. between stages (K)	Element style (cap. length)	Bulb size (mm)	Element finish	Setting (see page 2 adjustment)	Max. bulb temp (°C)	Bulb well (optional)	Order number
------------	---------------------	--------------------------	-----------------------------	----------------	----------------	---------------------------------	---------------------	----------------------	--------------

Type A28AA Capillary Thermostats, General Purpose IP30

-35 to +10	2	1 to 4	1b(2m)	9.5 x 110	Tin-plated	set low	60	WEL14A602R	A28AA-9006
-5 to +28	1.5	1 to 4	1b(2m)	9.5 x 135	Tin-plated	set low	60	WEL14A603R	A28AA-9007
-5 to +28	1.5	1 to 4	1b(5m)	9.5 x 135	Tin-plated	set low	60	WEL14A603R	A28AA-9106
1 to 60	2	1 to 4	1b(3m)	9.5 x 115	-	set high	85	WEL14A602R	A28AA-9118

Type A28AA Space thermostat

0 to +43	1.5	1 to 4	3	-	St. Steel	set high	60	-	A28AA-9113
----------	-----	--------	---	---	-----------	----------	----	---	-------------------

Type A28QA Capillary Thermostats, Splashproof IP65, Dust-tight Case

-35 to +10	2	1 to 4	1b(2m)	9.5 x 110	Tin-plated	set low	60	WEL14A602R	A28QA-9110
-5 to +28	1.5	1 to 4	1b(2m)	9.5 x 135	Tin-plated	set low	60	WEL14A603R	A28QA-9111
-35 to +40	2	1 to 4	1b(3.5m)	9.5 x 110	Tin-plated	set low	60	WEL14A602R	A28QA-9114
1 to 60	2	1 to 4	1b(3m)	9.5 x 115	-	set high	60	WEL14A602R	A28QA-9115

Type A28QA Space Thermostats, Splashproof IP65, Dust-tight Case

0 to +43	1.5	1 to 4	3	-	St. Steel	set high	60	-	A28QA-9113
----------	-----	--------	---	---	-----------	----------	----	---	-------------------

Type A28QA Capillary Thermostats, Splashproof IP65, Dust-tight Case, Concealed adjustment. For use on cooling-towers evaporative condensers, or air cooled condensers

5 to 50	2	4	1b(2m)	9.5 x 110	Tin-plated	set low	100	WEL14A602R	A28QA-9101
---------	---	---	--------	-----------	------------	---------	-----	------------	-------------------

Type A28QJ Capillary Thermostats, Splashproof IP65, Dust-tight Case For use on heat pumps and heat recovery units

10 to 95	1.5	1 to 4	1b(3m)	9.5 x 100	-	set low	115	WEL14A602R	A28QJ-9100
----------	-----	--------	--------	-----------	---	---------	-----	------------	-------------------

Note: If what you need is not in the specific type numbering selection table then please contact your representative.

Sensor styles

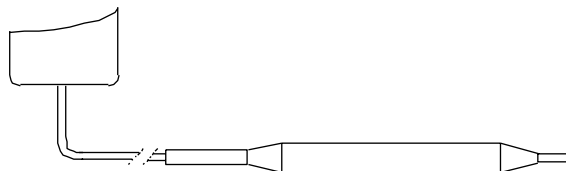

Fig. 3
Style 1b

swaged bulb, can be used with closed-tank connector **FTG13A-600**

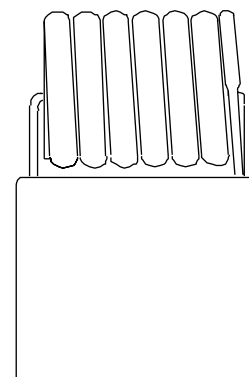
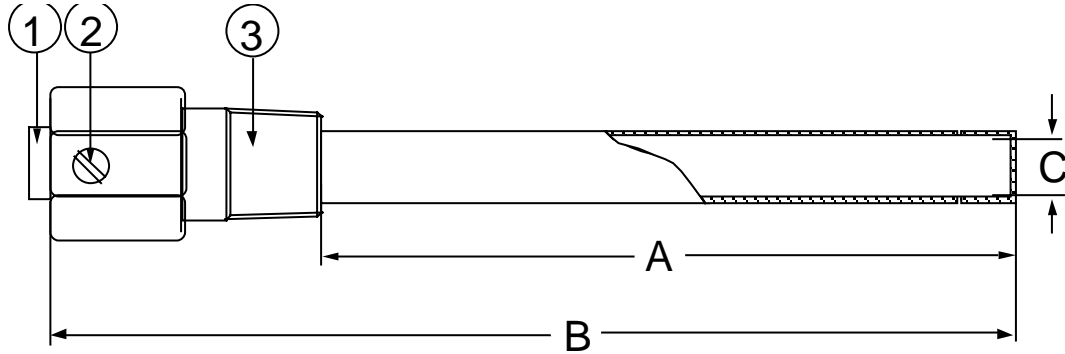

Fig. 4
Style 3 (coil)

Accessories (optional)



Order no.	Dimension A	Dimension B	Dimension C Internal
WEL14A602R	125 mm	171 mm	9.8 mm
WEL14A603R	147 mm	193 mm	9.8 mm

1. Bushing
 2. Set screw
 3. Adapter, 1/2"-14 NPT
- Bulb well (brass, copper pipe)**

Fig. 5

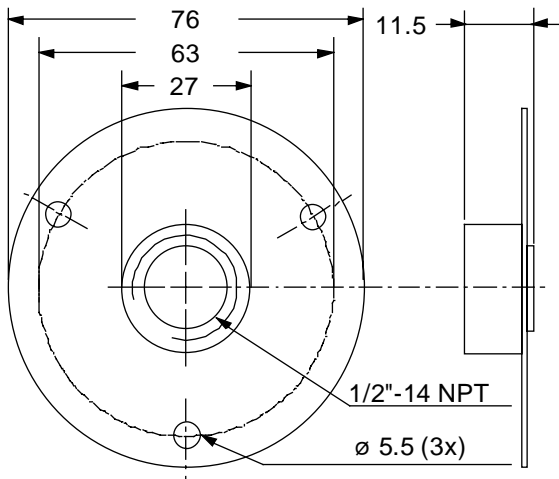
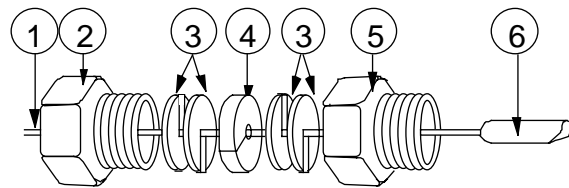

Fig. 6

Duct flange to be used with closed-tank connector FTG13A-600R.
Order number T-752-1001



1. Style 1b bulb support tube
2. Packing nut
3. Washer
4. Packing
5. Adapter, 1/2"-14 NPT
6. Bulb

Fig. 7

Closed-tank connector
Order number FTG13A-600R

Dimensions (mm)

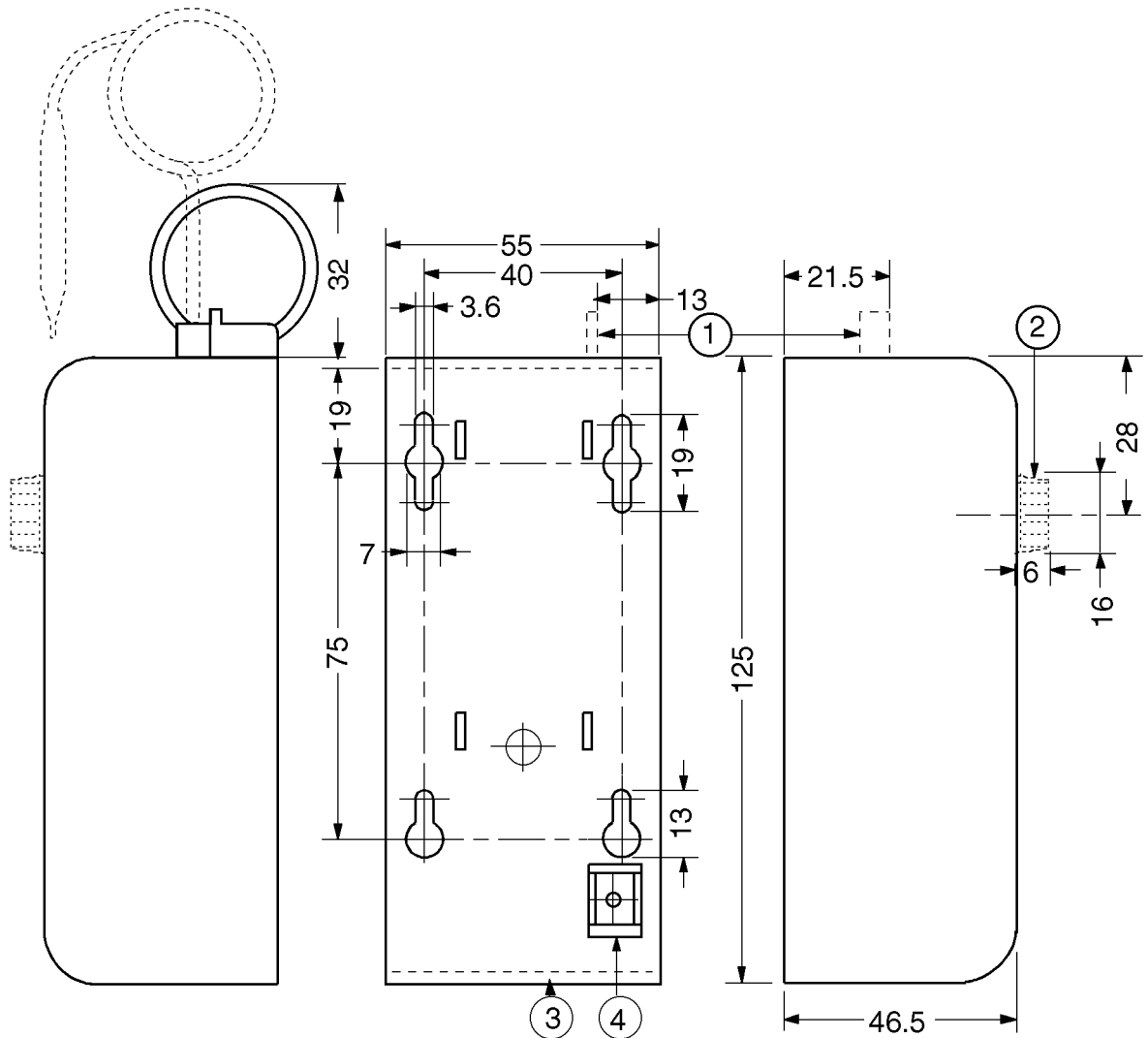

Fig. 8
A28AA (standard IP30 enclosure)

- 1 Reset lever
- 2 Knob packed separately with the control
- 3 22.3 mm dia. cable inlet hole for PG-16
- 4 Earth screw

Dimensions (mm)

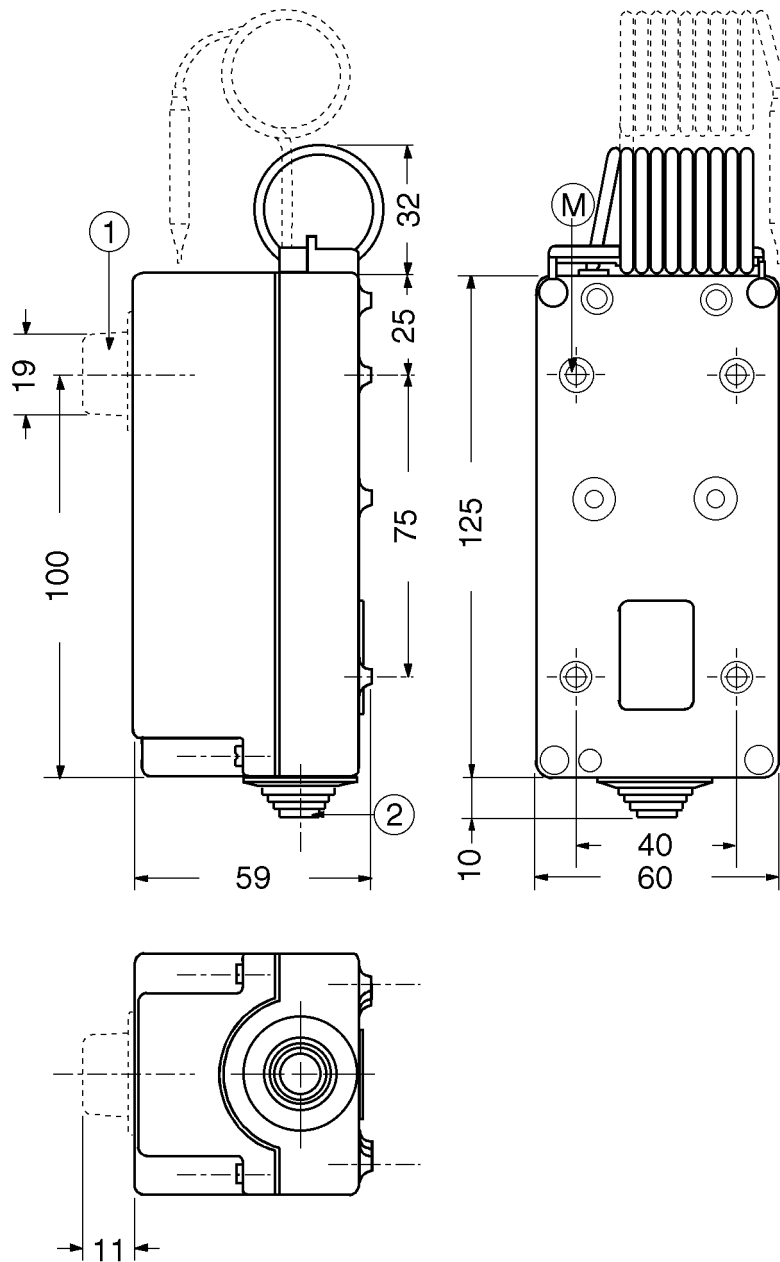

Fig. 9
A28Q/QJ (splash-proof IP65, dust-tight enclosure)

- 1 Knob (knob models only)
- 2 Cable grommet \varnothing 5 to \varnothing 13 mm
- M** 4 Mounting holes \varnothing 4.5 mm use 2 holes only

Notes

Specifications

Type number	A28AA (standard IP30 enclosure)		A28QA/QJ (splashproof, dust-tight IP65 enclosure)	
Element style	Style 1b bulb element	Style 3	Style 1b bulb element	Style 3
Application	General purpose -	Space -	General purpose Cooling towers and air-cooled condensers	Space (out-door and agriculture) -
Operating ranges	See type number selection table			
Differentials	See type number selection table			
Adjustment	Universal	-	External knob (general purpose) Concealed under cover (cooling-tower and air-cooled condensers) Controls with adjustable differential between stages have an adjustment lever under the cover	
Material Case Cover	1.75 mm cold-rolled zinc plated steel 1.5 mm ABS plastic		Polycarbonate Blue-colour finish Polycarbonate Blue-colour finish	
Conduit opening	22.3 mm dia. hole for PG16		Cable grommet. Conduit opening also applicable for PG16 connector	
Amb. temp. limits	-35 to +55°C		-35 to +55°C	
CE Conformity	According to low voltage directive and EMC directive			
Electrical ratings	~15(5)A 230V		~15(5)A 230V (A28QJ: ~15(3)A 230V)	
Enclosure	IP30		IP65	
Shipping weight	ind. pack 0.4 kg	overpack 10 kg (24 pcs.)	0.5 kg 12 kg (24 pcs.)	

The performance specifications are nominal and conform to acceptable industry standards. For applications at conditions beyond these specifications, consult the local Johnson Controls office or representative. Johnson Controls shall not be liable for damages resulting from misapplication or misuse of its products.

**JOHNSON
CONTROLS**

Johnson Controls International, Inc.

Headquarters: Milwaukee, WI, USA
 European Headquarters: Westendhof 8, 45143 Essen, Germany
 European Factories: Lomagna (Italy), Leeuwarden (The Netherlands) and Essen (Germany)
 Branch Offices: Principal European Cities.
 This document is subject to change

Printed in Europe

Series A36

3- and 4 Stage Thermostats for Refrigeration, Cooling, Heating, Ventilation and Air-conditioning

Introduction

Designed for multi-stage thermostatic operation of electrically controlled equipment such as:

- packaged liquid chillers
- heat pumps
- electric duct heaters
- computer room airconditioners

Description

Models are available in 'open' construction for panel mounting. Single knob adjustment moves the entire staging band up and down within the range of the control. The differential on each stage and sequencing between stages are factory set.

This permits the OEM to completely engineer the cycling of their equipment without the hazard of field mis-adjustments and erratic sequencing.



A36 Three and Four Stage Thermostat

Note

These controls are designed for use only as operating controls. Where an operating control failure would result in personal injury or loss of property it is the responsibility of the installer to add devices or systems that protect against, or warn of, control failure.

Feature and Benefits	
<input type="checkbox"/> Dust-tight SPDT switches	Prevents pollution of the contacts by electrostatic influences
<input type="checkbox"/> Cushion mounted	Prevents vibrations and chattering contacts
<input type="checkbox"/> Operation from a single, liquid filled element	Easy mounting
<input type="checkbox"/> Case compensation standard on all models	Assures uniform performance at different ambient conditions

Repair and Replacement

Repair is not possible. In case of an improperly functioning control, please check with your nearest supplier. When contacting the supplier for a replacement you should state the

type/model number of the control. This number can be found on the data plate or cover label.

Contact functions

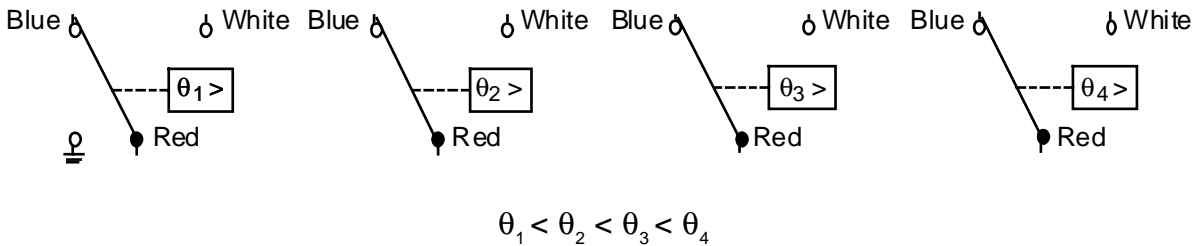
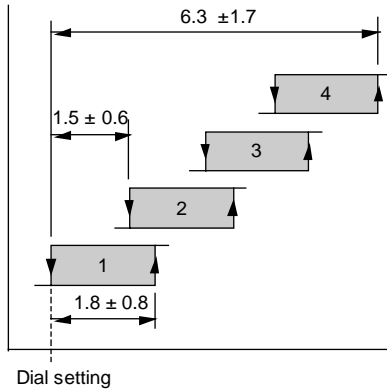
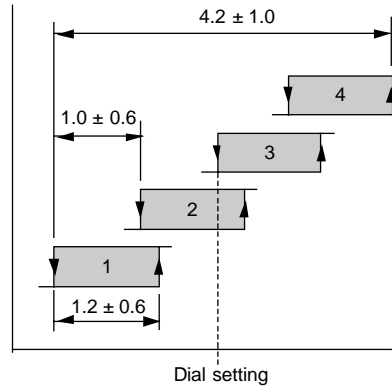

Fig. 1
Red - white closes on temperature increase.

Adjustment codes and tolerances



B1 Chiller/refrigeration standard differential



B2 Range close differential

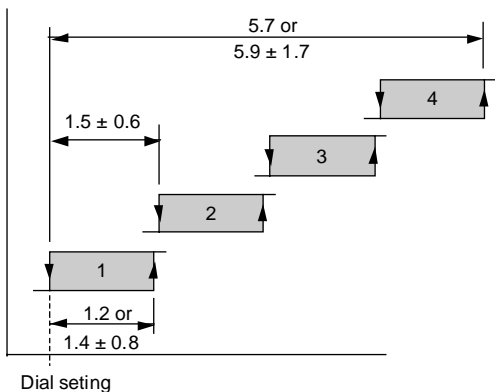

C1 Air-conditioning/heating standard differential

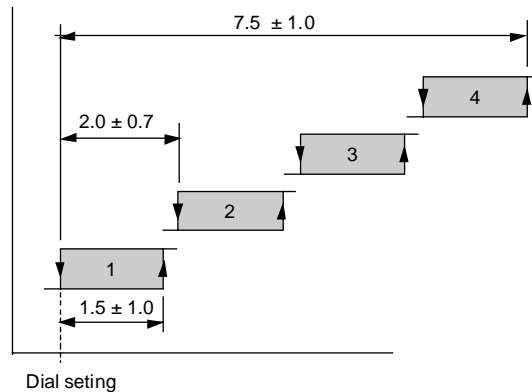

D2 Range wide differential

*T*ype number selection table:

Range °C	Diff. each stage	Between stage diff.	Adj. code	Bulb 9.5 mm Ø x length (mm)	Cap. length (m)	Special features	Electrical rating Amp. ~230V	Order number
----------	------------------	---------------------	-----------	-----------------------------	-----------------	------------------	------------------------------	--------------

3 stage models

-18 to +20	1.8	1.5	B1	125	5.0	PVC armoured	15(5)	A36AGA-9101
-18 to +20	1.8	1.5	B1	125	3.5	PVC armoured	15(5)	A36AGA-9102
-18 to +20	1.2	1.5	B2	125	3.5	PVC armoured	15(3)	A36AGB-9103
15 to 35	1.2	1.0	C1	140	3.5	PVC armoured	15(5)	A36AGA-9103

4 stage models

-18 to +20	1.8	1.5	B1	125	3.5	PVC armoured	15(5)	A36AHA-9105
-16 to +20	1.8	1.5	B1	125	5.0	PVC armoured	15(5)	A36AHA-9107
15 to 35	1.2	1.0	C1	140	3.5	PVC armoured	15(5)	A36AHA-9108
10 to 95	1.5	2.0	D2	100	3.0		15(3)	A36AHB-9103
-18 to +20	1.2	1.5	B2	125	3.5	PVC armoured	15(3)	A36AHB-9104
-18 to +20	1.2	1.5	B2	125	5.0	PVC armoured	15(3)	A36AHB-9105
-15 to +30	1.4	1.5	B2	110	5.0		15(3)	A36AHB-9109

Accessories (optional)

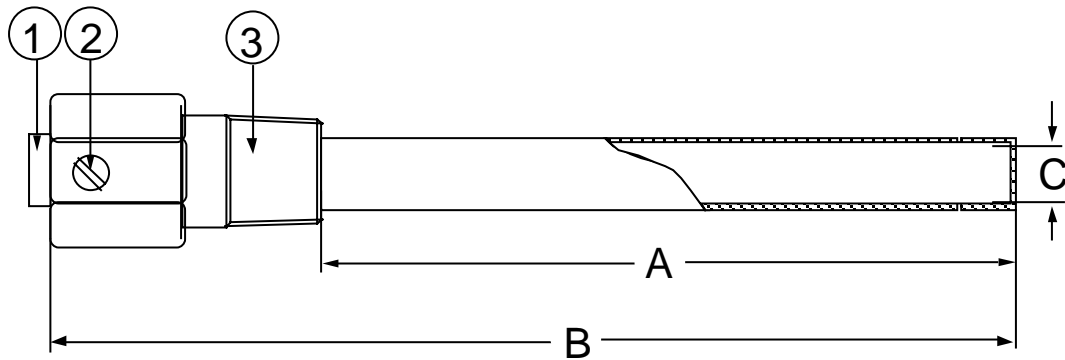

Order no.	Dimension (A)	Dimension (B)	Dimension (C) Internal
WEL14A602R	125 mm	171 mm	9.8 mm
WEL14A603R	147 mm	193 mm	9.8 mm

Fig. 3
Bulb well (brass, copper tube)

- C. Bushing
- D. Set screw
- E. Adapter, 1/2"-14 NPT

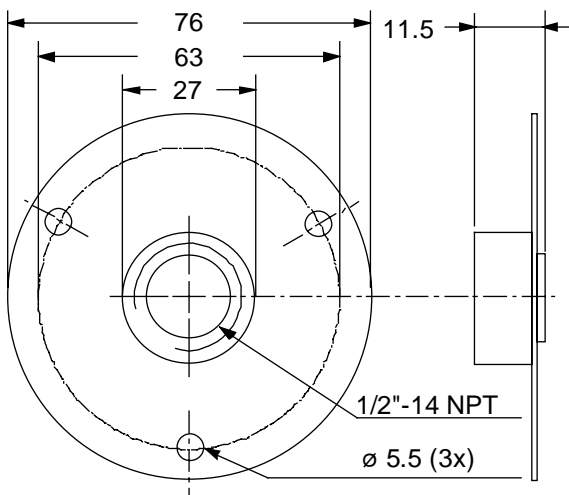

Fig. 4
Duct flange to be used with closed-tank
connector FTG13A-600R.
order number T-752-1001

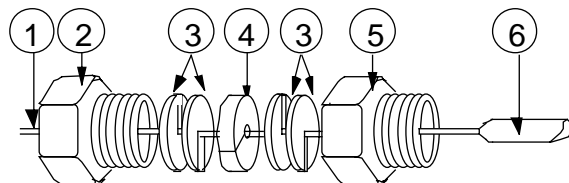

Fig. 5
Closed-tank connector
order number FTG13A-600R

- 1. Style 1b bulb support tube
- 2. Packing nut
- 3. Washer
- 4. Packing
- 5. Adapter, 1/2"-14 NPT
- 6. Bulb

Element styles

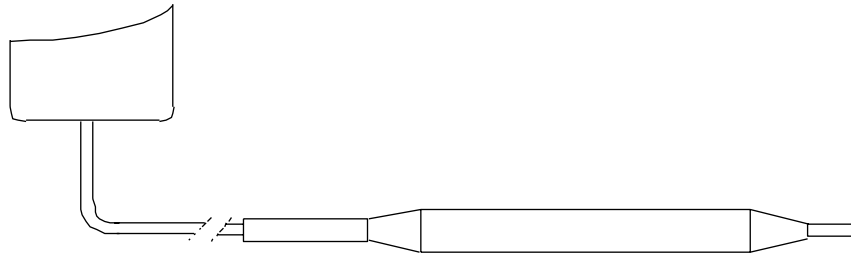
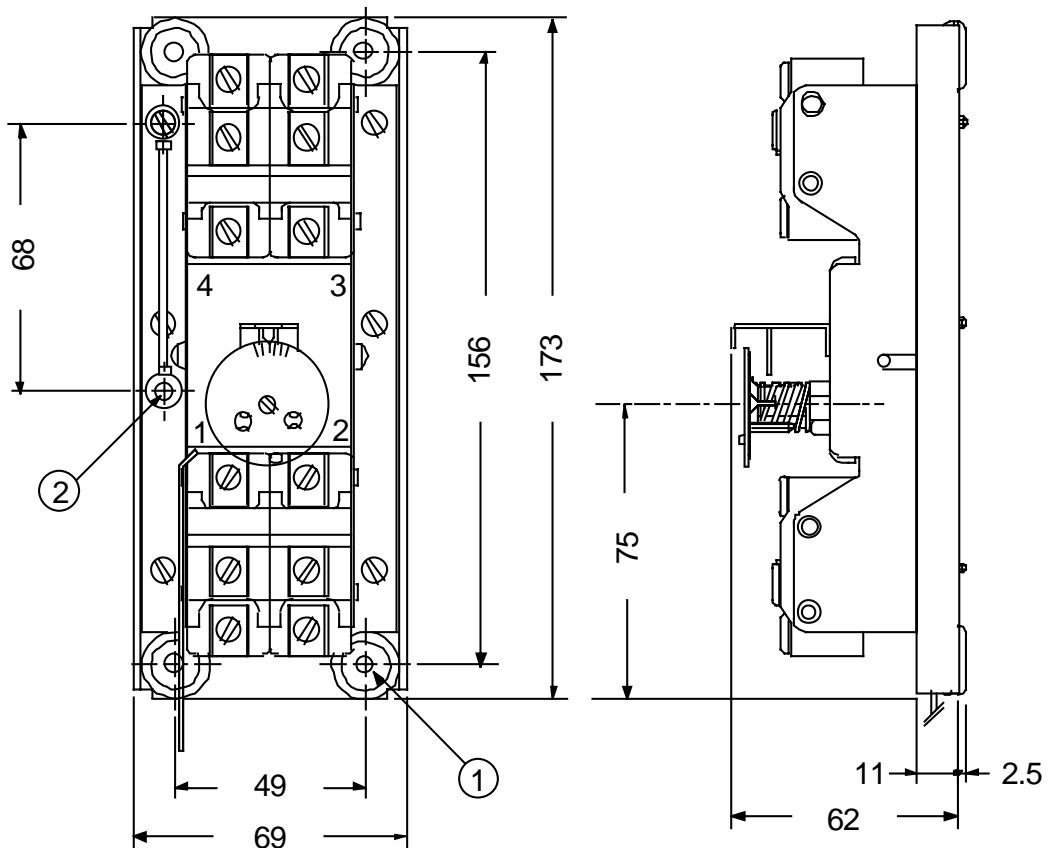

Fig. 6
Style 1b

Can be used with closed tank connector FTG13A-600RR

Dimensions (mm)



1. 4 Mounting grommets \varnothing 4.5 mm
2. Earth wire

Fig. 7

Notes

Notes

Specifications

CE Conformity	According to low voltage directive and EMC directive	
Element style	Liquid filled, copper bulb Ø 9.5 mm and capillary tube	
Operating ranges and differentials	See corresponding type number selection table.	
Adjustment	Calibrated dial and pointer	
Max. bulb temperature after installation	50 °C	
	115 °C for A36AHB-9103	
	75 °C for A36AHB-9109	
Max. temperature	+55 °C	
Shipping weights	Individual pack	1 kg
	Over pack	14 kg (14 pcs)
Contact functions	SPDT, snap-acting, enclosed and dust-tight switches	

The performance specifications are nominal and conform to acceptable industry standards. For applications at conditions beyond these specifications, consult the local Johnson Controls office or representative. Johnson Controls shall not be liable for damages resulting from misapplication or misuse of its products.



Johnson Controls International, Inc.

Headquarters:

Milwaukee, WI, USA

European Customer Service Center:

Westendhof 3, D-45143 Essen, Germany

European Factories:

Lomagna (Italy), Leeuwarden (The Netherlands) and Essen (Germany)

Branch Offices:

Principal European Cities.

This document is subject to change

Printed in Europe

PRODUCT BULLETIN

**MR10 Electronic Controls
for compressor and defrost management**

The MR10 range of controllers has been specifically designed for 'static' or 'ventilated' refrigeration units working at positive or negative temperatures. It incorporates all the features needed by modern units such as compressor and evaporator fan full management, 'off-cycle' or 'active' defrost control.

Particular emphasis has been given to the cost, the MR10 offers the basic features for a complete solution maintaining the cost at a very competitive level.

Its style has been particularly studied in order to better suit your machine design.



**MR14 controller
with defrost and fan management**

Features and Benefits

<input type="checkbox"/> Attractive Panel mount enclosure	Easy and quick installation
<input type="checkbox"/> Up to 4 relays in a single package	Reduced space
<input type="checkbox"/> Up to 16A thermostat output	Allows direct control of compressor without the need for an additional contactor.
<input type="checkbox"/> 230Volt power supply models available	Reduced installation time
<input type="checkbox"/> Accurate and interchangeable IP 68 sensor	Accurate control performance No recalibration needed
<input type="checkbox"/> Wide range of sensors with various enclosures available	Possibility to match a wide variety of temperature sensing needs
<input type="checkbox"/> SMD technology	Higher quality and reliable components
<input type="checkbox"/> Keyboard lock	Avoids accidental tampering by personnel

General feature

Display

The display has three 7-segment LEDs to display temperatures from -40°C to +70°C (-40 to 158°F). See Individual LEDs Status table here below.

Sensor input

This range of controllers uses Johnson Controls A99 temperature sensor. Its accuracy is within 0.5°C between -15 and 75°C. Its tolerance increases at temperatures outside this range, as shown below.

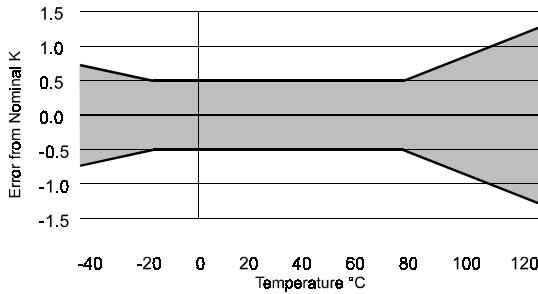

Its gas tight packaging makes it the best sensor for refrigeration applications. *For details please refer to A99 documentation.* An offset of the measured temperature can be configured for temperature compensation or cable extension.

Adjustable setpoint limits

The setpoint range can be limited in order to avoid “too high” or “too low” setpoint setting of the equipment. The final user cannot set a setpoint value exceeding these limits.

Anti short cycle protection

In order to protect the compressor against short cycling all models have a built-in anti short cycle protection. This feature determines the minimum time that must elapse between two start-ups of a compressor.

Keyboard lock

A sequence of keystrokes allows you to disable/enable modification of the internal parameters. This prevents unauthorised personnel from making parameter modifications.

Self-testing procedure

This feature helps you to check the installation and configuration of the controller once installed. After the keystroke sequence + , it will cycle all outputs and flash all LED's.

Deep freezing

From the front panel, by pressing simultaneously the + keys it's possible to force the compressor output ON for a pre-set time in order to start a freezing cycle. This feature is very handy when a loading operation of a cold room or a display cabinet is performed and there is the need to bring down the temperature very quickly.

Alarm management

All devices include a high and low temperature limit alarm. This alarm is related to the main setpoint of the thermostat and displays “Hi” or “Lo” in case of exceeding temperature limits. A delay can be configured in order to prevent non-significant events from triggering the alarm (i.e. door open). The differential of the alarm is also adjustable. On models with defrost management, this alarm is disabled during defrost and for a period after defrost cycle.

Events such as a disconnected or short-circuited sensor will be detected, signaled and will result in a selectable status of the output relay(s). The output cannot only be forced permanently ON or permanently OFF, but it can also be switched ON and OFF alternately. This new and innovative function will control the output of the compressor according to the average of the last 10 cycles, allowing both energy savings and goods preservation.

Units

Units can be selected from degree Celsius or Fahrenheit.

Output relay rating

Some models feature a 16A thermostat output which allows direct control of compressor without the need for an additional contactor.

LEDs Status table

LED	Status	Signification
	ON	compressor ON
	Blinking	deep-freezing cycle active
	ON	defrost cycle active
	ON	Fan ON

Dimensions (in mm)

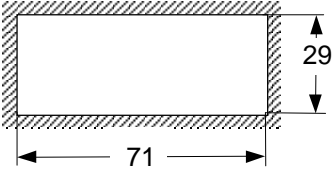
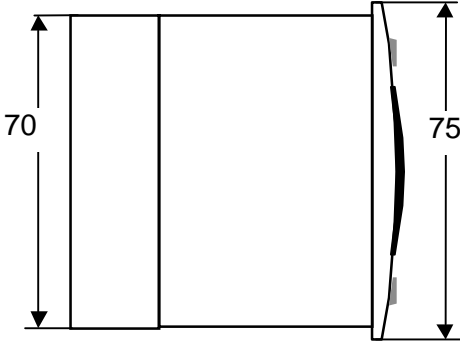
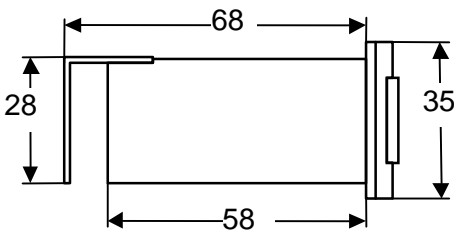
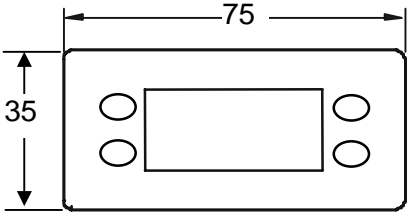

Panel cut-out

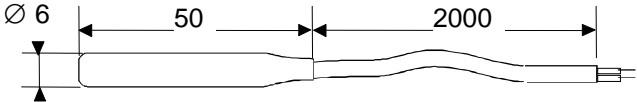

A99BB-200C Temperature sensor

Configuration

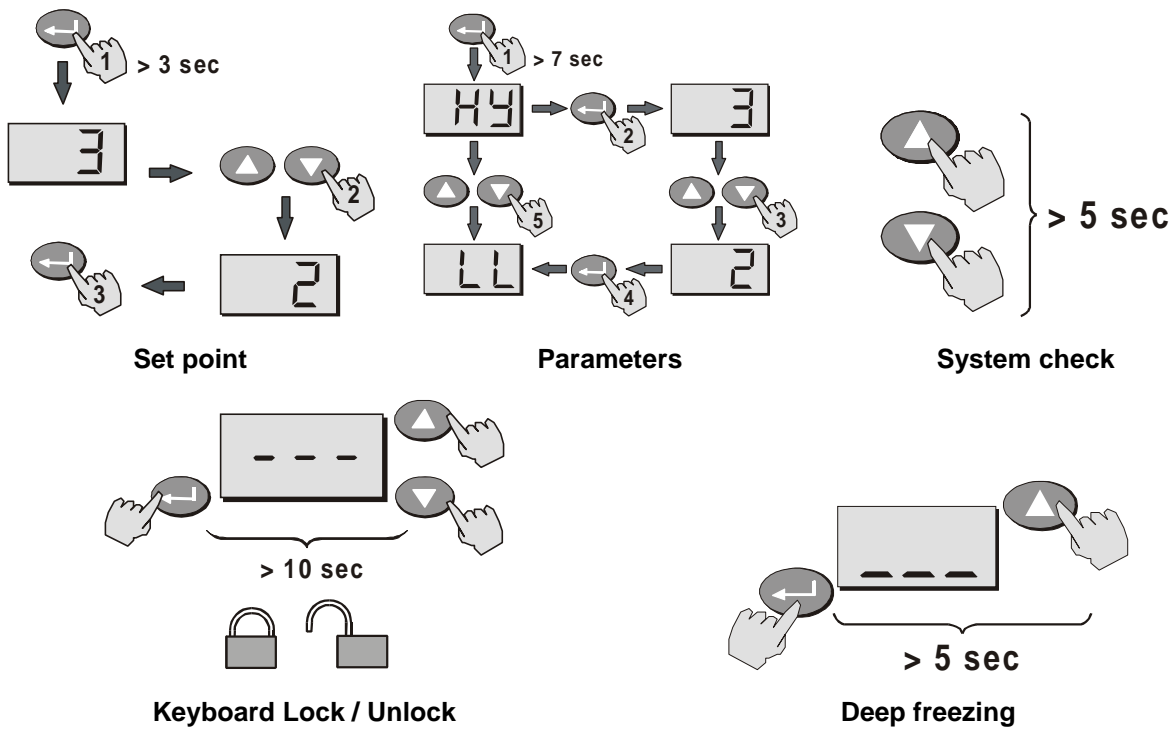

Wiring Instruction

WARNING

When wiring and servicing make sure that:

- the electric supply to the actuator is switched off to avoid possible damage to the equipment, personal injury or shock.
- you do not touch or attempt to connect or disconnect wires when electric power is on.

Note

These controls are intended to control equipment under normal operating conditions. Where failure or malfunction of the control could lead to an abnormal operating condition that could cause personal injury or damage to the equipment or other property, other devices (limit or safety controls) or systems (alarm or supervisory systems) intended to warn of or protect against failure or malfunction of the control must be incorporated into and maintained as part of the control system.

Compressor control - MR11

This control is specifically designed for the control of refrigeration units operating at positive temperatures.

Description

These controllers are equipped with an SPDT 8(3)A relay for the compressor control.

Two models are available, either with 12VAC/dc or 230Vac power supply.

Note: A detailed list of available parameters and their description can be found at the end of this documentation.

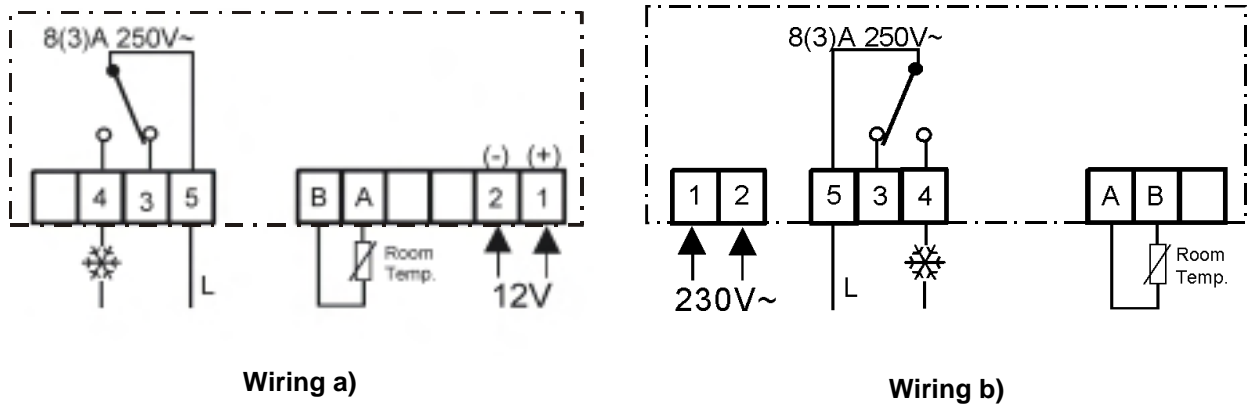

Selection table:

Item code	Enclosure	Power supply	Shipping weight	Wiring diagram
MR11PM12R-1C	Panel 75x35	12 Vac/dc 50/60 Hz	230 g	a)
MR11PM230-1C	Panel 75x35	230 Vac 50/60 Hz	300 g	b)

Note: Temperature sensor included in the package

Thermostat with “off cycle” defrost control - MR12

This control is specifically designed for the controls of static defrost refrigeration applications operating at positive temperatures.

Defrost functions

The defrost is initiated and terminated by a timer. The user sets the interval between successive cycles and its duration.

During the defrost cycle, the display can show either the last measure before defrost or the setpoint. You can also delay the normal display function after a defrost cycle ends.

Manual defrost is possible by pressing the defrost key on the keypad.

Digital input functions

All defrost controllers are equipped with a digital input performing the following functions:

1. General Alarm
2. Delayed Alarm
3. Door Switch

Note: A detailed list of available parameters and their description can be found at the end of this documentation.

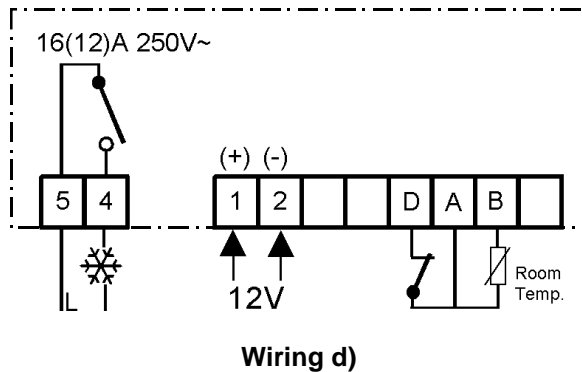
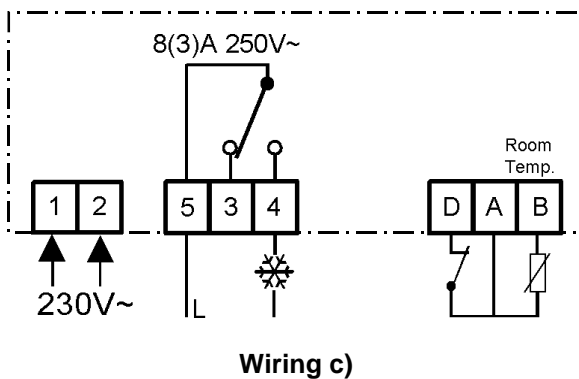
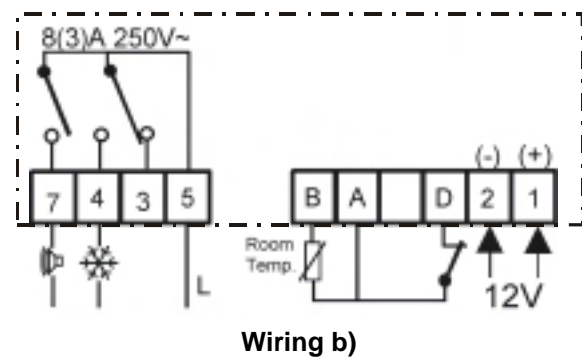
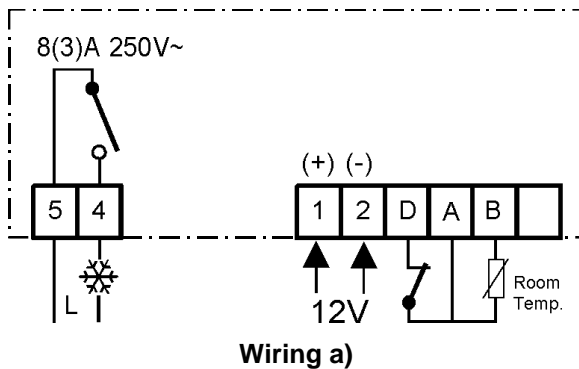

Selection table:

Item code	Enclosure	Power supply	Shipping weight	Wiring diagram
MR12PM12R-1C	Panel 75x35	12 Vac/dc 50/60 Hz	240 g	a)
MR12PM12R-A1C	Panel 75x35	12 Vac/dc 50/60 Hz	240 g	b)
MR12PM230-Z1C	Panel 75 x 35	230 Vac 50/60 Hz	240 g	c)
MR12PM12H-1C	Panel 75 x 35	12 Vac/dc 50/60 Hz	260 g	d)

Note: Temperature sensor included in the package

Thermostat with active defrost management - MR13

This control is specifically designed for the control of static units working at medium, low temperatures, requiring active defrost.

This control is equipped with two sensors, one for the control of the refrigeration unit, the other sensor manages the evaporator temperature.

Defrost functions

The defrost cycle is initiated by a timer and terminated either by temperature or time, whichever is first fulfilled.

The defrost function includes the following parameters:

- Types of defrost (Hot gas or electrical heating).
- Interval time to adjust defrost frequency.
- Defrost termination: time or temperature.
- Defrost end temperature.
- Defrost maximum duration time.

You can stop the compressor for an additional configurable period called dripping time. This will allow the evaporator to dry prior to resuming normal operation.

In case of evaporator sensor failure, the defrost cycle will be terminated by the maximum defrost duration.

During defrost the display can be configured to show the last measurement before defrost or the setpoint.

Multifunctional digital input

The digital input (normally closed) can be configured according to the unit requirements. The functions available are:

1. General Alarm
2. Delayed Alarm
3. Door Switch

Note: A detailed list of available parameters and their description can be found at the end of this documentation

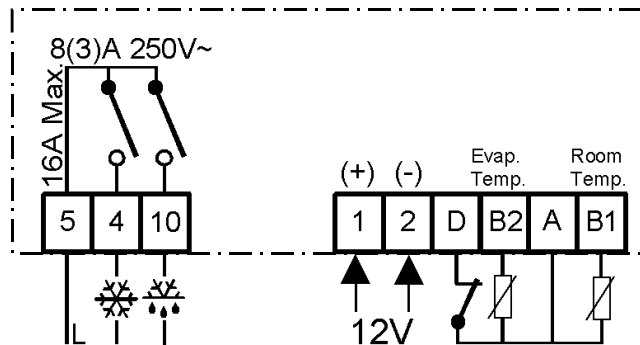

Wiring a)

Selection table:

Item code	Enclosure	Power supply	Shipping weight	Wiring diagram
MR13PM12R-2C	Panel 75x35	12 V ac/dc 50/60 Hz	330 g	a)

Note: Two Temperature sensors are included in the package

Thermostat with defrost and fan management - MR14

This control is specifically designed for the control of ventilated refrigeration applications requiring active defrost such as hot gas or electrical. This is also suitable for a small plant.

This control is equipped with two sensors, one for the control of the refrigeration unit, the other sensor manages the evaporator temperature.

Defrost functions

The defrost cycle is initiated by a timer and terminated either by temperature or time, whichever is first fulfilled.

The defrost function includes the following parameters:

- Types of defrost (Hot gas or electrical heating).
- Interval time to adjust defrost frequency.
- Defrost termination: time or temperature.
- Defrost end temperature.
- Defrost maximum duration time.

You can stop the compressor for an additional configurable period called dripping time. This will allow the evaporator to dry prior to resuming normal operation.

In case of evaporator sensor failure, the defrost cycle will be terminated by the maximum defrost duration.

During defrost the display can be configured to show the last measurement before defrost or the setpoint.

Fan management functions

With the MR4 models you can choose whether the fan is to be run in parallel with the compressor or whether it should remain constantly ON. In any case the fan is switched OFF during defrost. After defrost, the fan can resume its work after a preset time or after the evaporator temperature has dropped below an adjustable temperature.

Digital input functions

All defrost controllers are equipped with an additional digital input which can be configured to perform the following functions:

1. General Alarm
2. Delayed Alarm
3. Door Switch

Note: A detailed list of available parameters and their description can be found at the end of this documentation.

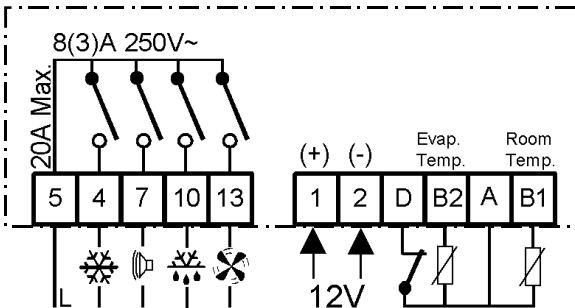

Wiring a)

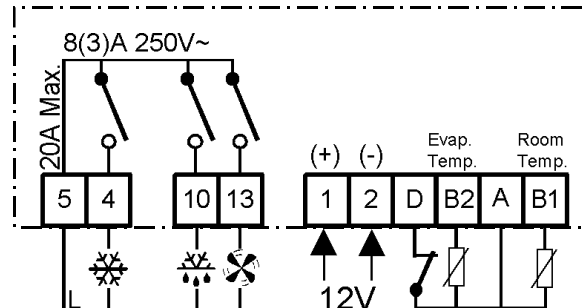

Wiring b)

Selection table :

Item code	Enclosure	Power supply	Shipping weight	Wiring diagram
MR14PM12R-A2C	Panel 75x35	12 V ac/dc 50/60 Hz	330 g	a)
MR14PM12R-2C	Panel 75x35	12 V ac/dc 50/60 Hz	330 g	b)

Note: Two temperature sensors are included in the package

Description of each parameter

Setpoint:

is defined as the relay cut OFF.

Hy Hysteresis

This is the difference between the temperature at which the compressor output is switched OFF and the temperature at which the output is switched ON. This is an absolute value, related to the setpoint.

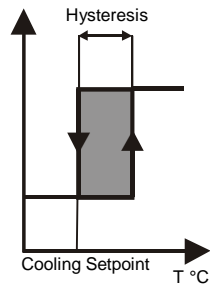

Example:

Cooling Setpoint = 4°C.
Differential = 2 K.
The compressor is switched ON when the temperature goes over 6°C, and is turned OFF when the temperature decreases to 4°C.

LL/HL Lower & Higher setpoint limit

The setpoint value cannot be adjusted outside the limits defined by these parameters, to avoid improper setpoint setting by the user.

CC Anti short cycle protection

This parameter prevents the compressor from being turned ON / OFF too often. The value that you set is the minimum time between two subsequent switches ON of the output.

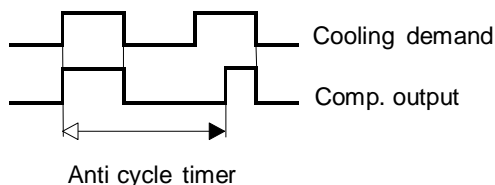

Co Deep freezing time

This is the time for which the compressor is forced ON when pressing the deep freezing cycle key from the faceplate.

AH High temperature alarm

High temperature alarm value relative to setpoint.
E.g. If your set point is at 4°C and AH = 5K the alarm will be triggered at 9°C.

AL Low temperature alarm

Low temperature alarm value relative to setpoint.
E.g. If your set point is at 4°C and AL = 3K below setpoint, it will be triggered at 1°C.

Ad Alarm differential

Useful to avoid alarm oscillation.

For example:

Setpoint = 4°C

Max. temperature alarm = 6 K

Alarm differential = 2 K

In this case, when the cold room temperature exceeds $4+6 = 10^{\circ}\text{C}$ for a time greater than parameter 9 the alarm is activated; when temperature drops below $4+6-2 = 8^{\circ}\text{C}$ the alarm is reset.

At Alarm time delay

Delay between the detection of the temperature alarm and the activation of the alarm sequences. This is useful to prevent temporary conditions from causing an alarm. Furthermore, the controller automatically ignores the temperature alarm condition in the following cases:
- for 20 minutes after the power-ON
- during defrost and for 20 minutes after the defrost-end.

dF Defrost function

Select the type of your installation and the way defrost is performed:

0 = Electrical defrost (Compressor OFF)

1 = Hot gas defrost (Compressor ON).

dE Defrost end function

Select the defrost termination type:

0 = timer based set with parameter **dd**

1 = temperature based set with param. **dt**.

Note: in any case the defrost ends after the time set through parameter **dd**.

dt Defrost termination temperature

Used only when parameter **dE** = 1.

When the evaporator temperature reaches this value, the defrost automatically ends.

di Defrost interval time

This is the time between two subsequent defrost cycles. This timer will initiate every defrost cycle.

dd Maximum defrost duration

The defrost cycle will stop after this time, even if the defrost end temperature has not been reached.

dC Dripping time

After defrost is terminated, the compressor is stopped to allow the evaporator to drip.

dU	<p>First defrost cycle after power-on</p> <p>This parameter allows to delay a defrost cycle, after power-up. This will prevent a cycle from occurring before the cold room has reached its operation temperature. This function is disabled when set to "OF".</p>	FF	<p>Fan operating function</p> <p>0 = fan runs in parallel to the compressor 1 = fan is always ON <i>Note:</i> in both cases, the fan is switched OFF during the defrost cycle.</p>
dP	<p>Display during defrost</p> <p>You can select what to display during the defrost cycle. This is meant to avoid misleading users during the defrost cycle. 0 = last measured value before defrost cycle 1 = setpoint</p>	Fd	<p>Fan start-up delay after defrost end and power up</p> <p>This parameter is a safety function, the fan is activated after this time even if the temperature set through parameter (Fr) has not been reached.</p>
dr	<p>Delay displayed temperature after defrost</p> <p>During defrost cycles the ambient temperature is not displayed (see parameter dp). The actual temperature returns to display when its value reaches the setpoint value or, in any case, after the time defined by this parameter.</p>	Fr	<p>Fan start temperature after defrost end and power up</p> <p>Evaporator sensor temperature at which the fan is switched ON, after defrost cycle, <i>Note:</i> in any case the fan is switched ON after the time set through parameter (Fd).</p>
iF	<p>Digital input function</p> <p>The digital input (normally closed) can be configured according to the plant requirements: 0 = the DI is not connected 1 = General Alarm: If the contact stays open (On) for longer than parameter id then:</p> <ul style="list-style-type: none"> • all outputs are de-energised; • an alarm message (A1) is displayed; • the alarm output is energised (if present). <p>The alarm condition automatically resets as soon as the contact closes back. 2 = Delayed Alarm: If the contact stays open (On) for longer than parameter id then:</p> <ul style="list-style-type: none"> • an alarm message (A2) is displayed; • the alarm output is energised (if present). <p>All other functions continue as usual, the alarm condition resets as soon as the contact closes back. 3 = Door Switch: As soon as the contact opens (On) the fan is switched off (if applicable) and if it stays open for longer than parameter id then:</p> <ul style="list-style-type: none"> • an alarm message (A3) is displayed; • the alarm output is energised (if present). <p>High and low alarms are disabled. The condition automatically resets as soon as the contact closes back.</p>	SF	<p>Thermostat operating function when sensor failure</p> <p>This defines the cycle of the thermostat output in case of failure 0 = Compressor ON 1 = Compressor OFF 2 = Automatic In the automatic mode, the controller will calculate the average time the compressor was ON for the last 10 cycles, and the compressor will run accordingly. If a deep freezing cycle or a defrost cycle occurred, they will not be taken into account nor will the first cycle afterwards.</p>
id	<p>Digital input time delay</p> <p>Time between the detection of the digital input opening and the enabling of the function selected through parameter (iF).</p>	So	<p>Offset thermostat sensor</p> <p>This value is added to or subtracted from the measured value to compensate for possible field measurement offset errors. To compensate for extra long copper cabling use the following formula:</p> $Compensation = -\frac{5 \times length}{1000 \times area} K, \text{ where}$ <p><i>length</i> = length of the cable in meters <i>area</i> = section of the cable in square millimetres and compensate for the calculated value</p>
		Un	<p>Temperature units</p> <p>0 = Celsius degrees, 1 = Fahrenheit degrees.</p>
		PU	<p>Display updating time delay</p> <p>The temperature value display of the MR will be refreshed with this defined period. It will not affect the control performance.</p>

Parameters

	Parameter	Setting Range	Default	MR11	MR12	MR13	MR14
Temperature control parameters							
Hy	Hysteresis (HY)	1 to 9 K	2	•	•	•	•
LL	Lower setpoint limit (LL)	-40°C to higher limit	-40	•	•	•	•
HL	Higher setpoint limit (HL)	lower limit to 70°C	70	•	•	•	•
CC	Anti short cycling (CC)	0 to 9 min	2	•	•	•	•
Co	Deep freezing time (Co)	0 to 99 min	60	•	•	•	•
Alarm parameters							
AH	High. temperature alarm	0 to 50°C related to setpoint	10	•	•	•	•
AL	Low temperature alarm	-50 to 0°C related to setpoint	-10	•	•	•	•
Ad	Alarm differential	1 to 9 K	1	•	•	•	•
At	Alarm time delay	0 to 99 min	30	•	•	•	•
Defrost parameters							
dF	Defrost function	0 = Electric heater 1 = Hot gas	0			•	•
dE	Defrost end function	0= by time 1= by temperature	1			•	•
dt	Defrost termination temp	0 to 20°C	7			•	•
di	Defrost interval time	0 to 99 hours	6		•	•	•
dd	Max. defrost duration	0 to 99 min	40		•	•	•
dC	Dripping time	0 to 99 min	5		•	•	•
dU	First defrost after power on	OFF, 0 to 99 min	OF		•	•	•
dP	Display during defrost	0 = Last value before defrost 1 = Set point	0		•	•	•
dr	Delay displayed temp after defrost	1 to 99 min	20		•	•	•
Digital input parameters							
iF	Digital input function	0= not connected 1= High Level Al. 2= Delayed Alarm 3= door switch	0		•	•	•
id	Digital input time delay	0 to 99 min	5		•	•	•
Fan control parameters							
FF	Fan operating function	0 = Parallel with compressor 1 = Continuous <i>Always OFF during defrost</i>	0				•
Fd	Fan start-up delay after defrost end and power up	0 to 99 min.	5				•
Fr	Fan start-up temperature after defrost end and power up	-30 to +5 °C	-5				•

	Parameter	Setting Range	Default	MR11	MR12	MR13	MR14
Other parameters							
SF	Thermostat operating function if sensor failure	0 = Always ON 1 = Always OFF 2 = Automatic	2	•	•	•	•
So	Sensor offset	-20 to +20 k	0	•	•	•	•
Un	Temperature units	0 = °C 1 = °F	0	•	•	•	•
PU	Display updating time	1 to 99 sec	1	•	•	•	•

Accessories

Item Code	Description
TR230/12-1	Transformer 230 / 12,3 VA
A99BB-200C	Sensor, cable length: 2m

Alarm and Fault Codes

Error Codes and Status

Error Code (Codes will flash on the display)	System Status
F1 Open or shorted room temperature sensor	Alarm output energised (if present) Compressor output in function of param. SF Cycle power to reset
F2 Open or shorted evaporator temperature sensor	Alarm output energised (if present) Defrost end only by time Fan managed in parallel to compressor Automatic reset
A1 Digital input open for longer than param. id and iF = 1	Alarm output energised (if present) All other outputs go OFF Automatic reset
A2 Digital input open for longer than param. id and iF = 2	Alarm output energised (if present) Automatic reset
A3 Digital input open for longer than param. id and iF = 3	Alarm output energised (if present) Automatic reset
HI Calculated case temperature has reached or exceeded (Setpoint + AH)	Alarm output energised (if present) Automatic reset
LO Calculated case temperature has reached or fallen below (Setpoint + AL)	Alarm output energised (if present) Compressor output OFF Automatic reset
EE Program failure	Replace controller

Repair and replacement

Field repair is not possible. In case of defective or improperly functioning control, please check with your nearest supplier. When contacting the supplier for replacement, you should state the type-model number of the control. This number can be found on the data plate.

Specifications

Product	MR10 Electronic Controls				
Power Requirements	12 VAC/dc $\pm 10\%$, 50/60 Hz 230 VAC $\pm 10\%$, 50/60 Hz	Not all power supplies are available in every version. Please refer to selection tables.			
Power Consumption	2 VA				
Protection Class	Panel mount	Front plate	IP 54		
		Rear	IP 20		
Ambient Operating Conditions	-10° to +55°C (14° to 131°F) 10 to 95 % RH (non condensing)				
Ambient Storage Conditions	-30° to +80°C (-22° to +176°F) 0 to 95 % RH (non condensing)				
Range	-40 to +70°C				
Accuracy & Precision	$\pm 1^\circ\text{C}$				
Sensor cable	2 meters				
Output ratings	(250 VAC)	Compressor	Alarm	Defrost	Fan
	MR11PM12R-1C	SPDT 8(3)A			
	MR11PM230-1C	SPDT 8(3)A			
	MR12PM12R-A1C	SPDT 8(3)A	SPST 8(3)A		
	MR12PM12R-1C	SPDT 8(3)A			
	MR12PM230-Z1C	SPDT 8(3)A			
	MR12PM12H-1C	SPDT 16(12)A			
	MR13PM12R-2C	SPST 8(3)A		SPST 8(3)A	
	MR14PM12R-2C (*)	SPST 8(3)A		SPST 8(3)A	SPST 8(3)A
	MR14PM12R-A2C (*)	SPST 8(3)A	SPST 8(3)A	SPST 8(3)A	SPST 8(3)A
	(*) Max. current on common = 20 Amps				
Dimensions (H x W x D)	Panel mount	35 x 75 x 68 (1.38" x 2.95" x 2.68")			
Compliance	73/23 EEC directive: EN 60730 89/336 EEC directive: EN 50081-1, EN 50082-2				

The performance specifications are nominal and conform to acceptable industry standards. For application at conditions beyond these specifications, consult the local Johnson Controls office. Johnson Controls, Inc. shall not be liable for damages resulting from misapplication or misuse of its products. This document is subject to change without prior notice.



Johnson Controls International, Inc.

Headquarters: Milwaukee, WI, USA

European Headquarters: Westendhof 8, 45143 Essen, Germany

European Factories: Lomagna (Italy), Leeuwarden (The Netherlands) and Essen (Germany)

Branch Offices: Principal European Cities.

This document is subject to change

MR40 Advanced Electronic Control for Compressor and Defrost management

The MR40 is a digital controller for “static” or “ventilated” refrigeration units working at positive or negative temperatures. It incorporates all the features needed by modern units such as compressor and evaporator fan full management, “off-cycle” or “active” defrost control, additional auxiliary output for alarm signalling or light control.

The MR40 functions can be further expanded through other elements such as the LON or Johnson Controls N2Open serial communication card. It is also optionally equipped with a Real Time Clock card for energy saving and real time scheduling of events such as defrost cycles.



MR44 controller with active defrost and fan management

Features and Benefits



<input type="checkbox"/> Attractive Panel mount enclosure	Easy and quick installation
<input type="checkbox"/> Up to 4 relays in the standard 35 x 72 mm enclosure	Reduced space
<input type="checkbox"/> Temperature display with “decimal” accuracy	Allows accurate control and reading of temperature.
<input type="checkbox"/> Accurate and interchangeable IP 68 sensor	Accurate control performance No recalibration needed
<input type="checkbox"/> Wide range of sensors with various enclosures available	Possibility to match a wide variety of temperature sensing needs
<input type="checkbox"/> SMD technology	Higher quality and reliable components
<input type="checkbox"/> LON and N2Open serial communication cards (optional)	Compatible with standard Building Automation Systems (BAS) protocols
<input type="checkbox"/> Real Time Clock (optional)	Real Time Scheduling of control activities

Features

Display

The display has three 7-segment LEDs to display temperatures from -40°C to $+70^{\circ}\text{C}$ (-40 to 158°F) with decimal accuracy between -9.9 and $+70.0^{\circ}\text{C}$ (-9.9 to $+99.9^{\circ}\text{F}$).

See Individual Status LEDs table:

LED	Status	Meaning
	ON	compressor ON
	Blinking	deep-freezing cycle active
	ON	defrost cycle active
	Slow blinking	auxiliary output energised
	Fast blinking	auxiliary output energised and defrost active
	ON	Fan ON

Sensor input

This series of controllers uses Johnson Controls A99 temperature sensor. Its accuracy is within 0.5°C between -15 and 75°C . Its tolerance increases with temperatures outside this range, as shown below.

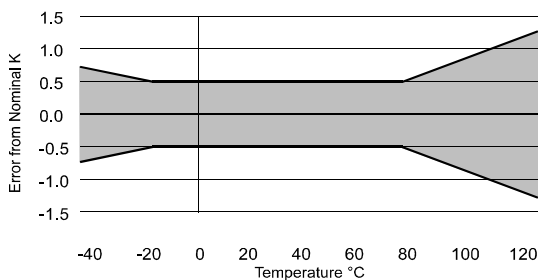

Its gas tight packaging (IP68) makes it the best sensor for refrigeration applications. *For details please refer to A99 documentation.* An offset of the measured temperature can be configured for temperature compensation or cable extension.

Adjustable setpoint limits

The setpoint range can be limited in order to avoid “too high” or “too low” setpoint settings of the equipment. The final user cannot set a setpoint value exceeding these limits.

Anti short cycle protection

In order to protect the compressor against short cycling all models have a built-in anti short cycle protection. This feature determines the minimum time that must elapse between two successive start-ups of the compressor.

Serial Communication (Optional)

The MR40 controller can be integrated in a Building Management System (BMS) thanks to plug-in communication cards. Two cards are available depending on the protocol needed: LON or N2Open. In alternative to RTC card.

Real Time Clock (Optional)

RTC plug-in card is available to allow real time scheduling of control activities such as defrost cycles and setpoint bias. In alternative to serial communication card.

Defrost Management

Defrost can be initiated by timer, RTC, digital input, network or manually forced through the keypad and terminated either by timer, evaporator temperature or network command.

Fan Management functions

The evaporator fan can be managed in three different ways, according to the FF parameter:

FF = 0: in parallel with compressor

FF = 1: always ON

FF = 2: based on the evaporator temperature and parameters FS (Fan differential), FH (Fan Hysteresis).

Note: FAN is always OFF during Defrost

Keyboard lock / unlock

A sequence of keystrokes allows you to disable/enable modification of the internal parameters. This prevents accidental tampering from unauthorised personnel.

Deep freezing

From the front keypad or from the network you can force the compressor output ON for a pre-set time in order to start a deep freezing cycle.

This feature is very useful when a cold room or refrigerated case loading operation is performed. Deep freezing is terminated by timer or if at least one of the following situations occur: temp. sensor failure, low temp. alarm, general alarm, OFF state selection, fan only mode selection and manual command from the keypad.

Alarm management

All devices include a high and a low temperature limit alarm. This alarm is related to the main setpoint of the thermostat and displays “Hi” or “Lo” in case of exceeding temperature limits. A delay can be configured in order to prevent non-significant events from triggering the alarm (i.e. door open).

The differential of the alarm is also adjustable.

The high temp. alarm is disabled for a programmable delay after power-up and after defrost end. Events such as a disconnected or short-circuited sensor will be detected, signalled and will result in a selectable status of the output relay(s).

Units

Measurement Unit can be selected: Celsius or Fahrenheit degrees.

Self Test

Through the Keypad is possible to activate the self-test procedure to check control operation by cycling all outputs and testing all LEDs.

Multifunctional Digital Input

All instruments are equipped with a digital input performing the following functions:

1. General Alarm
2. Delayed Alarm
3. Door switch
4. Setpoint Bias
5. Remote Defrost
6. oFF mode
7. Auxiliary command
8. Fan Only Mode

Programmable Digital Output

Some models have a programmable relay output that can be used either as an alarm or an auxiliary output (ex. light switch). This output is configured by configuration parameter (**AA**) or automatically configured as auxiliary by selecting the “auxiliary output control” function for the digital input (**iF = 7**). Once configured as auxiliary the relay can be energised by digital input, network or by simultaneously pressing the UP and DOWN arrows on the keypad.

Configuration

Available Keys	Action
	Up Scroll sensor readings and DI status. Scroll up parameters or increase a value.
	Down Scroll sensor readings and DI status. Scroll down parameters or decrease a value.
	for 3" < t < 7" GoTo setpoint setting(*)
	for 7" < t < 15" GoTo parameters setting
	for t > 15" GoTo RTC param. (if present)
	for t > 3" Manual defrost start
	for t > 3" Manual deep freezing start
	for t > 7" Manual deep freezing stop
	for t > 3" Auxiliar command toggle (if present)
	t > 10" Lock/Unlock keyboard
	for t > 3" Self test

Note

- If no key is pushed within 10 sec the controller will leave the config. mode and proceed with its normal functions. Changes made on timers will occur only after completing the current ones, while changes on other variables will have immediate effect.

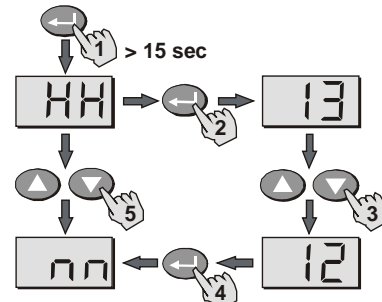

Real Time Clock Parameters

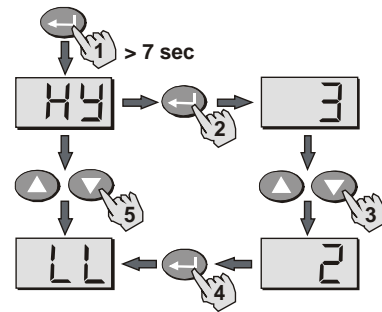

Parameters

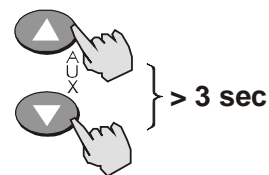

Auxiliary

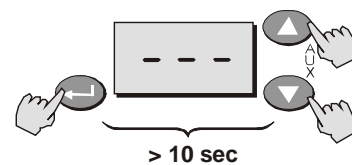

Keyboard Lock/Unlock

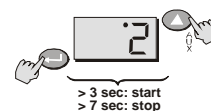

Start/Stop Deep Freezing

(*) Pressing "Enter" for 3 sec. will display the setpoint value that can be modified by the end user. Pressing "Enter" again will first display the Current Setpoint tag (CSP) and then it's value (Only Reading). This is the value used by the controller in the control algorithm. It can be equal to the setpoint ± the bias value (if inserted) or to the value super imposed by the network (if present).

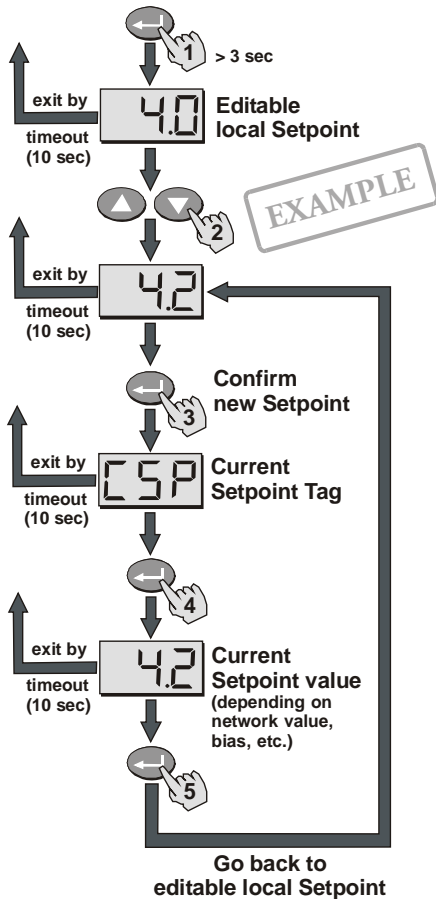

Example of Setpoint

Dimensions (in mm)

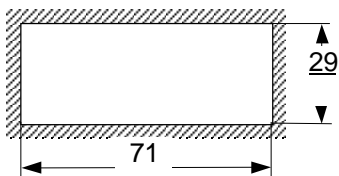
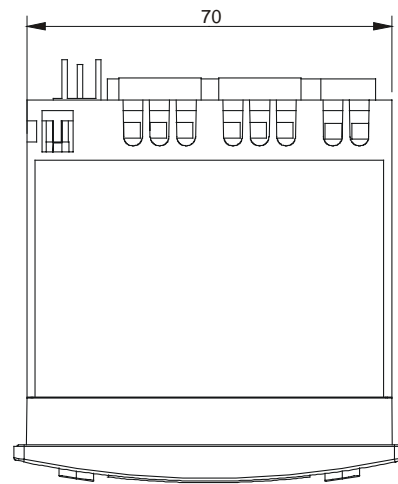
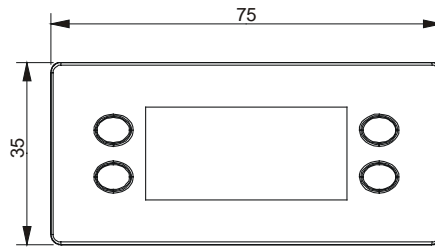
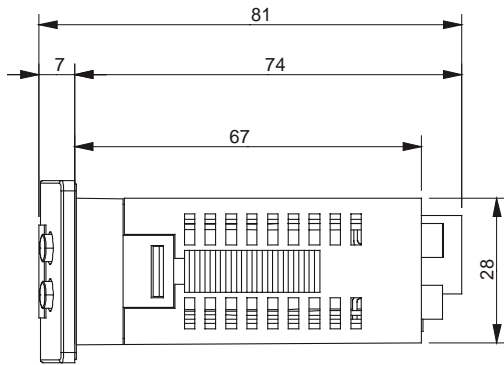

Panel cut-out

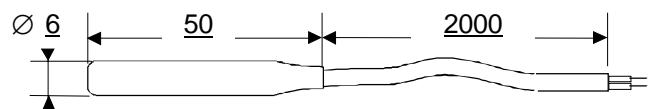

A99B-9108 Temperature sensor

Wiring Instruction



WARNING:

When wiring and servicing make sure that:

- the electric supply to the actuator is switched off to avoid possible damage to the equipment, personal injury or shock.
- you do not touch or attempt to connect or disconnect wires when electric power is on.

Note

- These MR40 are intended to control equipment under normal operating conditions. Where failure or malfunction of the MR40 could lead to an abnormal operating condition that could cause personal injury or damage to the equipment or other property, other devices (limit or safety controls) or systems (alarm or supervisory systems) intended to warn of or protect against failure or malfunction of the MR40 must be incorporated into and maintained as part of the control system.

Thermostat with “off cycle” defrost control - MR42

This control is specifically designed for the control of static refrigeration units working at positive temperatures where defrost is performed by compressor stop

Defrost functions

A defrost Cycle can be started by:

- Internal timer
- Real Time Clock (if present)
- Network (if present)
- Digital input
- Keypad

It can be terminated only by internal timer or by a network command.

The user sets the interval between two successive cycles and its duration.

During the defrost cycle, the display can show either the last measured temperature or the setpoint. You can also delay the normal display function after a defrost cycle ends.

Configurable output

The model **MR42PM12R-A1C** has a 2nd relay which can be used either as an alarm or an auxiliary output. The auxiliary output can be energised by digital input, network or by simultaneously pressing the “▲ + ▼” buttons on the keypad.

Multifunctional digital input

The digital input (normally closed) can be configured according to the unit requirements.

The functions available are:

- General Alarm
- Delayed Alarm
- Door Switch
- Setpoint Bias
- Remote Defrost
- OFF mode
- Auxiliary Output Control (*MR42PM12R-A1C only*)

Note: A detailed list of available parameters and their description can be found at the end of this documentation

Wiring diagrams

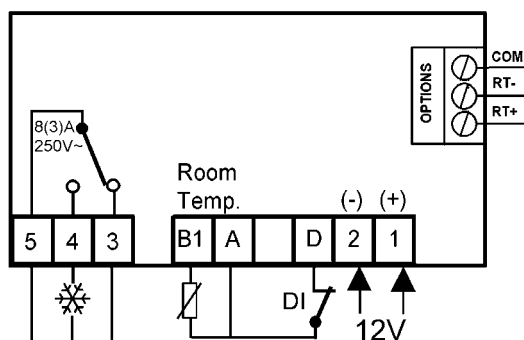

Wiring diagram a)

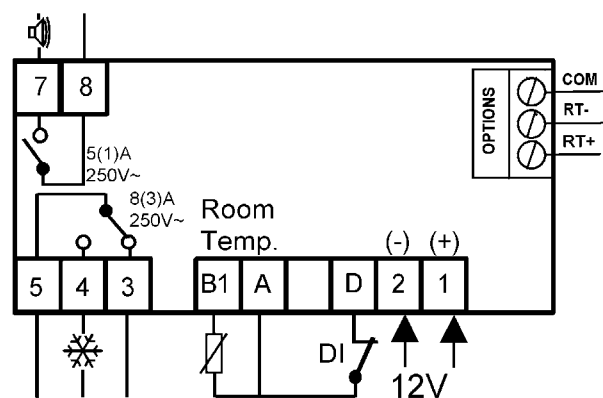

Wiring diagram b)

Selection table:

Item code	Enclosure	Power supply	Shipping weight	Wiring diagram
MR42PM12R-1C	Panel 75x35	12 Vac/dc 50/60 Hz	240 g	a)
MR42PM12R-A1C	Panel 75 x 35	12 Vac/dc 50/60 Hz	240 g	b)

Note: One temperature sensor is included in the package.

Thermostat with active defrost management - MR43

This control is specifically designed for the control of static units working at medium, low temperatures, requiring active defrost.

This control is equipped with two sensors, one for the control of the refrigeration unit, the other sensor manages the evaporator temperature.

Defrost functions

A defrost Cycle can be started by:

- Internal timer
- Real Time Clock (if present)
- Network (if present)
- Digital input
- Keypad

It can be terminated by internal timer, by evaporator temperature or by a network command. Defrost can be chosen between hot gas and electrical defrost.

You can stop the compressor for an additional configurable period called dripping time.

This will allow the evaporator to dry prior to resuming normal operation.

In case of evaporator sensor failure, the defrost cycle will be terminated by 130% of the maximum defrost duration.

During defrost the display can be configured to show the last measurement before defrost or the setpoint.

Multifunctional digital input

The digital input (normally closed) can be configured according to the unit requirements.

The functions available are:

- General Alarm
- Delayed Alarm
- Door Switch
- Setpoint Bias
- Remote Defrost
- OFF mode

Note: A detailed list of available parameters and their description can be found at the end of this documentation.

Wiring diagram

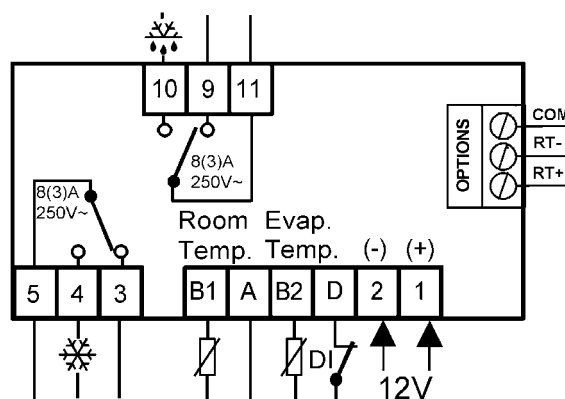

Wiring diagram a)

Selection table:

Item code	Enclosure	Power supply	Shipping weight	Wiring diagram
MR43PM12R-2C	Panel 75x35	12 Vac/dc 50/60 Hz	330 g	a)

Note: Two temperature sensors are included in the package.

Thermostat with defrost and fan management - MR44

This control is specifically designed for the control of ventilated units working at negative temperature.

This control is equipped with two sensors, one for the control of the refrigeration unit, the other sensor manages the evaporator temperature.

Defrost functions

A defrost Cycle can be started by:

- Internal timer
- Real Time Clock (if present)
- Network (if present)
- Digital input
- Keypad

It can be terminated by internal timer, by evaporator temperature or by a network command. Defrost can be chosen between hot gas, electrical or ambient defrost (by compressor stop only). You can stop the compressor for an additional configurable period called dripping time. This will allow the evaporator to dry prior to resuming normal operation.

In case of evaporator sensor failure and end of defrost by temperature selected, as a fail safe, the defrost cycle will be terminated at 130% of the maximum defrost duration (**dd**)

During defrost the display can be configured to show the last measurement before defrost or the setpoint.

Configurable output

This model has a relay which can be used either as an alarm or an auxiliary output. The auxiliary output can be energised by digital input, network or by simultaneously pressing the “▲ + ▼” buttons on the keypad.

Multifunctional digital input

The digital input (normally closed) can be configured according to the unit requirements.

The functions available are:

1. General Alarm
2. Delayed Alarm
3. Door Switch
4. Setpoint Bias
5. Remote Defrost
6. OFF mode
7. Auxiliary Output Control
8. Fan Only Mode

Selection table:

Item code	Enclosure	Power supply	Shipping weight	Wiring diagram
MR44PM12R-A2C	Panel 75x35	12 Vac/dc 50/60 Hz	330 g	a)

Note: Two temperature sensors are included in the package

Fan Management functions

The fan operations can be managed in three different ways, accordingly with the **FF** parameter:

FF = 0: in parallel with compressor

FF = 1: always ON

FF = 2: based on the evaporator temperature and parameters **FS** (Fan differential), **FH** (Fan Hysteresis).

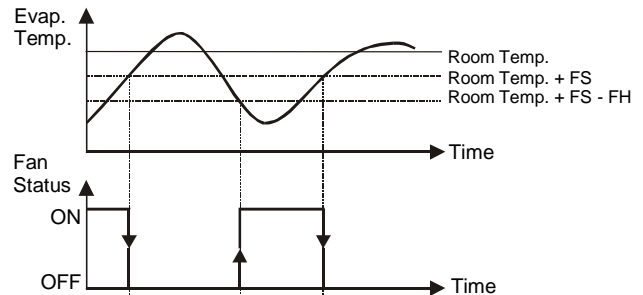

Note: FAN is always OFF during Defrost and for a programmable time after power-up and defrost end.

Note: A detailed list of available parameters and their description can be found at the end of this documentation.

Wiring diagram

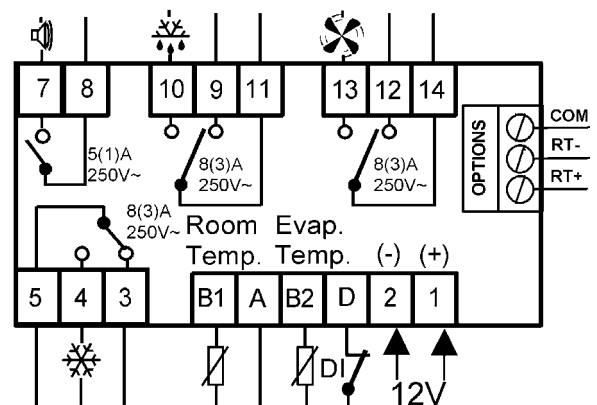

Wiring diagram a)

Description of each parameter

Setpoint:

is defined as the relay cut OFF.

Hy Hysteresis

This is the difference between the temperature at which the compressor output is switched OFF and the temperature at which the output is switched ON. This is an absolute value, related to the setpoint.

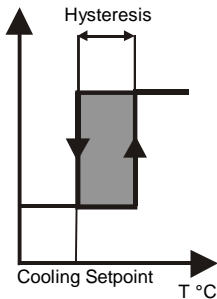

Example:
Cooling Setpoint = 4°C
Differential = 2 K
The compressor is switched ON when the temperature goes over 6°C, and is turned OFF when the temperature decreases to 4°C.

LL/HL Lower & Higher setpoint limit

The setpoint value cannot be adjusted outside the limits defined by these parameters, to avoid improper setpoint setting by the user.

CC Anti short cycle protection

This parameter prevents the compressor from being turned ON / OFF too often. The value that you set is the minimum time between two subsequent switches ON of the output.

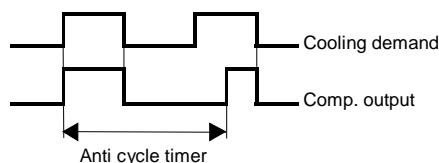

Co Deep freezing time

This is the time for which the compressor is forced ON when a deep freezing cycle is selected.

AH High temperature alarm

High temperature alarm value relative to setpoint. I.e. if your set point is at 4°C **AH = 5K** the alarm will be triggered at 9°C.

AL Low temperature alarm

Low temperature alarm value relative to setpoint. I.e. if your set point is at 4°C **AL = -3K** the alarm will be triggered at 1°C.

Ad Alarm differential

Useful to avoid alarm oscillation.

For example:

Setpoint = 4°C

High temperature alarm = 6K

Alarm differential = 2K

When the case temp. exceeds $4+6 = 10^\circ\text{C}$ for a time greater than **At** the alarm is activated; when the temp. drops below $4+6-2 = 8^\circ\text{C}$ the alarm is reset.

At Alarm time delay

Delay between the detection of the temperature alarm and the activation of the alarm sequences. This is useful to prevent temporary conditions from causing an alarm.

AC Alarm delay after power-up and defrost end

At power-up and after a defrost cycles the high temperature alarm will be disabled for "**AC**" minutes. The high temp. alarm is always disabled during defrost.

dF Defrost function

Select the type of your installation and the way defrost is performed

oFF = "Off-cycle" defrost (Compressor OFF)

ELE = Electric defrost (Compressor OFF)

HGA = Hot gas defrost (Compressor ON)

dn Defrost initiation mode

0 = Internal timer

1 = Real Time Clock

Note: to perform RTC defrost scheduling, RTC param. have to be configured (see RTC parameters)

dE Defrost end function

Select the defrost termination type:

0 = termination by evaporator temperature (parameter (**dt**))

1 = termination by time (parameter (**dd**))

2 = termination by first occurrence of the two: temperature or time

3 = termination by the last occurrence of the two: temperature or time.

In any case, should the evaporator sensor fail or for any other reason that may hinder the defrost end temperature to be reached, the defrost will end at 130% of the maximum defrost duration (**dd**).

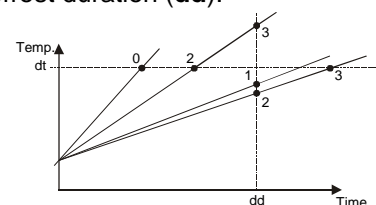

- dt Defrost termination temperature**
When the evaporator temperature reaches this value, the defrost automatically ends.
- di Defrost interval time**
This is the time between two subsequent defrost cycles. This timer will initiate every defrost cycle. If (**di**) and (**dd**) are set to zero defrost is disabled.
- dd Maximum defrost duration**
If defrost end by time has been selected (parameter **dE**) this is duration of a defrost cycle.
- dC Dripping time**
After defrost is terminated, the compressor is stopped to allow the evaporator to drip. Only if an active defrost is performed.
- dU First defrost cycle after power-on**
This parameter allows to delay a defrost cycle, after power-up. This will prevent a cycle from occurring before the cold room has reached its operation temperature.
This function is disabled when set to "oFF".
- dP Display during defrost**
You can select what to display during the defrost cycle. This is meant to avoid misleading users during the defrost cycle.
0 = last measured value before defrost cycle
1 = setpoint
- dr Delay displayed temperature after defrost**
During defrost cycles the ambient temperature is not displayed (see parameter **dP**). The actual temperature returns to be displayed after the time delay defined by this parameter.
- iF Digital input function**
The digital input (normally closed) can be configured according to the plant requirements:
0 = Not connected
1 = General Alarm: If the contact stays open (ON) for longer than parameter **id** then:
 - all outputs are de-energised
 - an alarm message (A1) is displayed and sent to the network
 - the alarm output is energised
The alarm condition automatically resets as soon as the contact closes back.
- 2 = Delayed Alarm:** If the contact stays open (ON) for longer than parameter **id** then:
 - an alarm message (A2) is displayed;
 - the alarm output energises.
 - an alarm is sent to the network.
All other functions continue as usual, the alarm condition resets as soon as the contact closes back (OFF).
- 3 = Door Switch:** As soon as the contact opens (ON) the fan is switched off (if applicable) and if it stays open for longer parameter **id** then:
 - an alarm message (A3) is displayed;
 - the alarm output is energised.
 - an alarm is sent to the network.
The condition automatically resets as soon as the contact closes back (OFF).
- 4 = Setpoint Bias:** As soon as the digital input opens (ON) we have a setpoint increase or decrease by the value set in parameter (**ib**).
- 5 = Remote Defrost:** If the contact opens (ON) a defrost cycle will start as soon as a preset delay (**id**) has elapsed. The command to the digital input has to be longer than 1 sec to be detected.
- 6 = OFF mode:** If the digital input opens then:
 - all outputs are switched OFF;
 - temperature is measured and displayed alternatively with OFF.
Controller will resume normal operations as soon as the contact closes back (OFF).
- 7 = Auxiliary Output Control:** if the digital input opens (ON) the auxiliary output is energised. Configuring **id** = 7 will automatically define the alarm/aux output as auxiliary. No alarm will effect the status of this relay any longer. (Applicable only for MR42PM12R-A1C, MR44PM12R-A2C).
- 8 = Fan Only Mode:** As soon as the digital input opens the controller enters this special mode:
 - all outputs but the evaporator fan will be de-energised;
 - all alarms disabled
 - "Fon" displayed
This mode is applicable only for the 4 relay model (MR44). Normal operation resumes as soon as the digital input closes back.
Especially useful for the cabinet complete defrosting prior to cleaning.
- id Digital input time delay**
Time between the detection of the digital input opening and the enabling of the function selected through parameter (**iF**).

ib Setpoint bias

This value is added to the setpoint when the digital input opens (if param. **iF** = 4)

FF Fan operating function

0 = fan runs in parallel to the compressor
1 = fan is always ON
2 = fan managed in function of the evaporator temperature and parameters **FS** (Fan setpoint temperature) and **FH** (Fan Hysteresis).

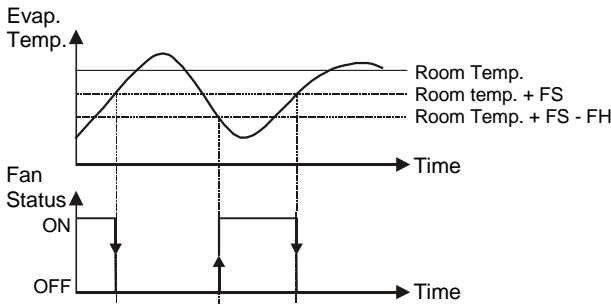

Note: in any case, the fan is switched OFF during the defrost cycle.

Fd Fan start-up delay after defrost end and power up

After defrost end and after start-up the fan start is delayed in order to make sure the evaporator temperature has dropped down. This is also a safety feature, the fan is activated after this time even if the temperature set through parameter (**Fr**) has not been reached.

Fr Fan start-up temp. after defrost end and after power-up:

Evaporator sensor temperature at which the fan is switched ON, after defrost cycle and after power-up.

Note: in any case the fan is switched ON after the time set through param. (**Fd**).

FS Fan differential

The sum of measured Room Temperature and Fan differential determines the point at which the fan is switched OFF.

FH Fan Hysteresis

Value used to avoid successive, too close, starts and stops of the evaporator fan. The value RoomTemp + **FS** - **FH** is the evaporator temperature below which the fan will start.

SF Thermostat operating function if sensor fails:

This defines the cycle of the thermostat output in case of failure:

- on** = Always ON
- oFF** = Always OFF
- AU**t = Automatic

In the automatic mode, the controller will cycle the compressor On and Off with a period based on historical cycles.

So Sensor Offset:

This value is added to or subtracted from the measured value to compensate for possible field measurement offset errors. To compensate for extra long copper cabling use the following formula:

$$Compensation = - \frac{5 \times length}{1000 \times area} K$$

Where:

length = length of the cable in meters

area = section of the cable in square millimetres and compensate for the calculated value

Un Temperature units

- 0** = Celsius degrees
- 1** = Fahrenheit degrees.

Pd Virtual Temperature

Up to two LON temperature sensors can be used to determine the room temperature.

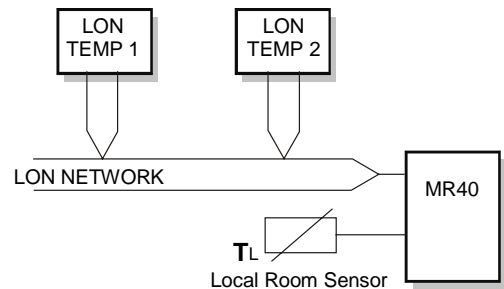

The temperature value used by the control algorithm is the result of following operation:

$$T_{Room} = T_x \times \frac{Pd}{100} + T_2 \left(1 - \frac{Pd}{100} \right)$$

Where:

$T_x = T_L$ if T_1 is not connected or invalid

$T_x = T_1$ if connected and valid

The Pd parameter is useful to have a weighted average between two temperatures that can be measured very far apart and also very far from the controllers itself if both Lon sensors are included. The sensor failure is related to a malfunctioning of the local probe T_L or of the LON T_1 sensor.

AA	<p>Programmable Digital Output</p> <p>The Alarm output, when present, can be configured either as alarm or auxiliary (ex. Light switch) output.</p> <p>0 = Alarm output. The relay is <i>energised if an alarm situation occurs</i>.</p> <p>1 = Auxiliary output. The output can be used for example to control the light of the cabinet or the door frame heater on a cold room application. The output can be activated by digital input (iF=7), by serial network or pressing simultaneously the UP and DOWN key on the key pad.</p>	bin	<p>Set point bias, Start Minute</p> <p>It configures the minute of the setpoint bias insertion.</p>
Add	<p>Serial Address</p> <p>Unit address for serial communication</p>	bi	<p>Set point bias, Status</p> <p>The set point bias can be turned ON or OFF. When ON, it will be performed every day of the week.</p>
HH	<p>RTC Hour setting</p> <p>It configures the hour of the Real Time Clock</p>	bSH	<p>Set point bias, Stop Hour</p> <p>It configures the hour at which the set point will return to its original value.</p>
nn	<p>RTC Minute setting</p> <p>It configures the minute of the Real Time Clock.</p>	bSn	<p>Set point bias, Stop Minute</p> <p>It configures the minute at which the set point will return to its original value.</p>
DAy	<p>RTC day of the week</p> <p>It configures the day of the week:</p> <p>0 = Sunday 1 = Monday 2 = Tuesday 3 = Wednesday 4 = Thursday 5 = Friday 6 = Saturday</p>		
dHx	<p>Defrost event No. x, start Hour</p> <p>It configures the defrost start hour of event number x (x = 1 to 6)</p>		
dnx	<p>Defrost event No. x, start Minute</p> <p>It configures the defrost start minute of event number x (x = 1 to 6)</p>		
ddx	<p>Defrost event No. x, week days</p> <p>This parameter allows to specify in which days of the week the event number x (x = 1 to 6) has to be carried out:</p> <p>0 = Never 1 = all days 2 = from Monday to Friday 3 = Saturdays & Sundays 4 = from Monday to Saturday 5 = Sunday only</p>		
biH	<p>Set point bias, Start Hour</p> <p>It configures the hour at which the set point will be biased to the value specified by parameter (ib)</p>		

Display parameters

Display code	Parameter	Setting Range	Default	MR42	MR43	MR44
Temperature control parameters						
Hy	Hysteresis	1 to 9 K	2	•	•	•
LL	Lower setpoint limit	-40°C to 70°C	-40	•	•	•
HL	Higher setpoint limit	-40°C to 70°C	70	•	•	•
CC	Anti short cycling	0 to 9 min	2	•	•	•
Co	Deep freezing time	0 to 99 min	60	•	•	•
Alarm parameters						
AH	Higher temperature alarm	0 to 50°C	10	•	•	•
AL	Low temperature alarm	-50 to 0°C	-10	•	•	•
Ad	Alarm differential	1 to 9 K	1	•	•	•
At	Alarm time delay	0 to 99 min	30	•	•	•
AC	Alarm delay after power-up and defrost	0 to 99 min	20	•	•	•
Defrost parameters						
dF	Defrost function	oFF (0) = "Off-Cycle" ELE (1) = Electric heater HGA (2) = Hot gas	ELE		•	•
dn	Defrost initiation mode	0 = Internal timer 1 = Real Time Clock	0	•	•	•
dE	Defrost end function	0 = by temperature 1 = by time 2 = first occurrence 3 = last occurrence	0		•	•
dt	Defrost termination temp	0 to 20°C	7		•	•
di	Defrost interval time	0 to 99 hours	6	•	•	•
dd	Max. defrost duration	0 to 99 min	40	•	•	•
dC	Dripping time	0 to 99 min	5	•	•	•
dU	First defrost after power on	oFF, 0 to 99 min	oFF	•	•	•
dP	Display during defrost	0 = Last value before defrost 1 = Set point	0	•	•	•
dr	Delay displayed temp after defrost	1 to 99 min	20	•	•	•
Digital input parameters						
iF	Digital input function	0 = Not connected 1 = General alarm 2 = Delayed alarm 3 = Door switch 4 = Setpoint bias 5 = Defrost start 6 = oFF mode 7 = AUX output control 8 = Fan only mode	0	•	•	•
id	Digital input time delay	0 to 99 min	5	•	•	•
ib	Set point bias	-10 to +10k	3	•	•	•

Display code	Parameter	Setting Range	Default	MR42	MR43	MR44
Fan control parameters						
FF	Fan operating function	0 = Parallel to compressor 1 = Always ON 2 = by temperature <i>Fan always OFF during defrost</i>	0			•
Fd	Fan start-up delay after defrost end and power-up	0 to 99 min.	5			•
Fr	Fan start-up temperature after defrost end and after power-up	-30 to +5 °C	5			•
FS	Fan differential	-30 to +5 °C	-5			•
FH	Fan hysteresis	0 to 20 °C	2			•
Other parameters						
SF	Thermostat functioning if sensor failure	on(1) = Always ON oFF(0) = Always OFF AUt(2) = Automatic	AUt	•	•	•
So	Sensor offset	-20 to +20 units	0	•	•	•
Un	Temperature units	0 = °C 1 = °F	0	•	•	•
Pd	Virtual temperature weight	0 to 100 %	0	•	•	•
AA	Programmable digital output	0 = alarm 1 = auxiliary	0	•		•
Add	Serial address	1 to 255	255	•	•	•
Real Time Clock parameters						
HH	Hour setting	0 to 23	0	•	•	•
nn	Minute setting	0 to 59	0	•	•	•
dAy	Day of the week setting	0 = Sunday 1 = Monday 2 = Tuesday 3 = Wednesday 4 = Thursday 5 = Friday 6 = Saturday	0	•	•	•
dHx x=1 to 6	Event No. x Hour setting	0 to 23	8	•	•	•
dnx x=1 to 6	Event No. x Minute setting	0 to 59	0	•	•	•
ddx x=1 to 6	Event No. x weekday setting	0 = Never 1 = all days 2 = from Monday to Friday 3 = Saturdays & Sundays 4 = from Monday to Saturday 5 = Sundays only	0	•	•	•
biH	Bias Start Hour	0 to 23	20	•	•	•
bin	Bias Start Minute	0 to 59	0	•	•	•
bi	Bias Status	on / oFF	oFF	•	•	•
bSH	Bias Stop Hour	0 to 23	0	•	•	•
bSn	Bias Stop Minute	0 to 59	0	•	•	•

Network parameters

Name	N2 Region	Addr	Short Name	LON type	SNVT #	Information Flow	Unit	Description	MR42	MR43	MR44
Network Variable Inputs (NVI)											
nviAirTemp1	ADF	5	adf-6	SNVT_temp_p	105	WRITE	°C	Network Case Temp. Sensor 1	•	•	•
nviAirTemp2	ADF	6	adf-7	SNVT_temp_p	105	WRITE	°C	Network Case Temp. Sensor 2	•	•	•
nviTemperature1	ADF	7	adf-8	SNVT_temp_p	105	WRITE	°C	Network Evaporator Sensor 1		•	•
nviTemperature2	ADF	8	adf-9	SNVT_temp_p	105	WRITE	°C	Network Evaporator Sensor 2		•	•
nviCutoutTemp	ADF	9	adf-10	SNVT_temp_p	105	WRITE	°C	Network Set Point	•	•	•
nviDefrostEnable (*)	BD	2	bd-3	SNVT_lev_disc	22	WRITE		Network defrost command	•	•	•
nviDayNight (*)	BD	3	bd-4	SNVT_lev_disc	22	WRITE		Network bias insertion command	•	•	•
nviOffNet (**)	ADF	10	adf-11	SNVT_switch	95	WRITE	%	Network selection of the OFF state	•	•	•
nviOffNet	BD	4	bd-5	SNVT_switch	95	WRITE		Network selection of the OFF state	•	•	•
nviFanOnly (**)	ADF	11	adf-12	SNVT_switch	95	WRITE	%	Network selection of the FAN Only Mode state			•
nviFanOnly	BD	5	bd-6	SNVT_switch	95	WRITE		Network selection of the FAN Only Mode state			•
NviDeepFreezing (**)	ADF	12	adf-13	SNVT_switch	95	WRITE	%	Network selection of the Deep Freezing mode	•	•	•
nviDeepFreezing	BD	6	bd-7	SNVT_switch	95	WRITE		Network selection of the Deep Freezing mode	•	•	•
NviAuxiliary (**)	ADF	13	adf-14	SNVT_switch	95	WRITE	%	Network command to the auxiliary output.	•		•
nviAuxiliary	BD	7	bd-8	SNVT_switch	95	WRITE		Network command to the auxiliary output.	•		•

(*): set the BD variable to 0 for OFF, to 4 for ON and to 255 for invalid: 0 (OFF), 4 (ON), 255 (invalid)

(**): set the ADF variable ≠ 0 at least once and then work with the correspondent BD variable: 0 (ON), 1 (OFF), 255 (invalid)

Name	N2 Region	Addr	Short Name	LON type	SNVT #	Information Flow	Unit	Description	MR42	MR43	MR44
Network Variable Outputs (NVO)											
NvoAirTemp	ADF	0	adf-1	SNVT_temp_p	105	READ	°C	Case temperature	•	•	•
NvoCutOutTemp	ADF	1	adf-2	SNVT_temp_p	105	READ	°C	Current setpoint (CSP)	•	•	•
NvoTemperature1	ADF	2	adf-3	SNVT_temp_p	105	READ	°C	Evaporator temperature		•	•
NvoDisplay	ADF	4	adf-5	SNVT_count_f	51	READ	°C	Case temperature shown on the display	•	•	•
NvoDefrostState	BD	0	bd-1	SNVT_defr_state	122	READ		Defrost Status: 0 (standby), 2 (defrost), 3 (Draindown)	•	•	•
NvoDigitalInput	BD	1	bd-2	SNVT_switch	95	READ		Status of the digital input: 0 (closed), 1 (open)	•	•	•
NvoOffState	BD	8	bd-9	SNVT_switch	95	READ		Thermostat status: OFF / ON; 0 (OFF), 1 (ON)	•	•	•
NvoThermostateState	ADI	0	Adi-1	SNVT_state	83	READ		Current state of the thermostat (*)	•	•	•
NvoState	DI1	1	Adi-2	SNVT_state	83	READ		I/O state (**)	•	•	•

(*): **NvoThermostatState** value depends from the activated bits with the following meanings:

Bit #	15	14	13	12	11	10	9	8	7	6	5	4	3	2	1	0
Value	32768	16384	8192	4096	2048	1024	512	256	128	64	32	16	8	4	2	1
Function	Controller in Alarm	Door Open	High temp. alarm	Low temp. alarm	Alarm level	Case temp. sensor failure	Evaporator coil sensor failure	General alarm from DI	Not used	Not used	Not used	Not used	Bias setpoint inserted	Not used	1 if cooling required 0 if cooling not required	Always at 1

(**): **NvoState** value depends from the activated bits with the following meanings:

Bit #	15	14	13	12	11	10	9	8	7	6	5	4	3	2	1	0
Value	32768	16384	8192	4096	2048	1024	512	256	128	64	32	16	8	4	2	1
Function	Not Used	Not Used	Not Used	Not Used	Not Used	Not Used	Not Used	Not Used	Not used	Not used	Not used	Not used	Defrost Output	Alarm/ Aux Output	Fan Output	Compr Output

Name	Display Code	N2 Region	Addr	Short Name	LON type	SNVT #	Inform. Flow	Unit	Min	Max	Def	Description	MR42	MR43	MR44
Network Configuration Parameters (CP)															
nciCutOutValue		ADF	17	adf-18	SNVT_temp_p	105	RD/WR	°C	-45	99	4	Setpoint	•	•	•
nciDifferenceValue	Hy	ADF	18	adf-19	SNVT_temp_p	105	RD/WR	°C	1	9	2	Hysteresis	•	•	•
nciLowSetpointLimit	LL	ADF	21	adf-22	SNVT_temp_p	105	RD/WR	°C	-40	70	-40	Lower setpoint limit	•	•	•
nciHighSetpointLimit	HL	ADF	20	adf-21	SNVT_temp_p	105	RD/WR	°C	-40	70	70	Higher setpoint limit	•	•	•
nciAntiShortCycle	CC	ADF	22	adf-23	SNVT_time_sec	107	RD/WR	sec	0	540	120	Anti short-cycling	•	•	•
nciDeepFreezingTime	Co	ADI	3	adi-4	SNVT_time_min	123	RD/WR	min	0	99	60	Deep freezing time	•	•	•
nciHighLimitTemp	AH	ADF	23	adf-24	SNVT_temp_p	105	RD/WR	°C	2	50	10	High temperature alarm	•	•	•
nciLowLimitTemp	AL	ADF	24	adf-25	SNVT_temp_p	105	RD/WR	°C	-50	-2	-10	Low temperature alarm	•	•	•
nciAlarmDifference	Ad	ADF	26	adf-27	SNVT_temp_p	105	RD/WR	°C	1	9	1	Alarm differential	•	•	•
nciAlarmDelay	At	ADF	25	adf-26	SNVT_time_sec	107	RD/WR	sec	120	5940	1800	Alarm time delay	•	•	•
nciTimealarmDis	AC	ADI	9	adi-10	SNVT_time_min	123	RD/WR	min	0	99	20	Alarm delay after power-up and defrost end.	•	•	•
nciDefrostMode	dF	BD	11	bd-12	SNVT_defr_mode	120	RD/WR		0	2	1	Defrost function		•	•
nciDefrostInitiationMode	dn	BD	21	bd-22	UNVT_enumeration	10175	RD/WR		0	1	0	Defrost initiation mode See dn parameter description	•	•	•
nciTerminateTimeTemp	dE	BD	12	bd-13	SNVT_defr_term	121	RD/WR		0	3	0	Defrost end function See dE parameter description		•	•
nciDefrostStopTemp	dt	ADF	27	adf-28	SNVT_temp_p	105	RD/WR	°C	0	20	7	Defrost termination temperature		•	•
nciDefrostInterval	di	ADI	6	adi-7	SNVT_time_min	123	RD/WR	min	0	5940	360	Defrost interval time	•	•	•
nciMaxDefrostTime	dd	ADI	4	adi-5	SNVT_time_min	123	RD/WR	min	0	99	40	Max. defrost duration	•	•	•
nciDrainDelay	dC	ADI	5	adi-6	SNVT_time_min	123	RD/WR	min	0	99	5	Dripping time	•	•	•
nciFirstDefrost	dU	ADI	7	adi-8	SNVT_time_min	123	RD/WR	min	0	99	65535 (OFF)	first defrost after power-up	•	•	•
nciDisplayDuringDef	dP	BD	13	bd-14	UNVT_logic	10149	RD/WR		0	1	0	Display during defrost See dP parameter description	•	•	•

Name	Display Code	N2 Region	Addr	Short Name	LON type	SNVT #	Inform. Flow	Unit	Min	Max	Def	Description	MR42	MR43	MR44
Network Configuration Parameters (CP)															
nciDelayDisplay	dr	ADI	8	adi-9	SNVT_time_min	123	RD/WR		1	99	20	Delay displayed temp. after defrost	•	•	•
nciDIFunction	iF	BD	9	bd-10	SNVT_enumeration	10175	RD/WR		0	8	0	Digital input function. See iF parameter description	•	•	•
nciDigitalInputDelay	id	ADI	2	adi-3	SNVT_time_min	123	RD/WR	min	1	99	5	digital input time delay	•	•	•
nciDeltaNight	ib	ADF	19	adf-20	SNVT_temp_p	105	RD/WR	°C	-10	10	3	Setpoint bias for night time operations	•	•	•
nciFanFunction	FF	BD	10	bd-11	SNVT_enumeration	10175	RD/WR		0	2	0	Fan operating functions. See FF param. description			•
nciFanDelay	Fd	ADI	10	adi-11	SNVT_time_min	123	RD/WR	min	0	99	5	Fan start up delay after power-up and defrost end			•
nciFanTemperature	Fr	ADF	28	adf-29	SNVT_temp_p	105	RD/WR	°C	-30	5	5	Fan start up temperature after defrost end			•
nciEvapFanSetpoint	FS	ADF	29	adf-30	SNVT_temp_p	105	RD/WR	°C	-30	5	-5	Fan differential			•
nciEvapFanHist	FH	ADF	30	adf-31	SNVT_temp_p	105	RD/WR	°C	0	20	2	Fan hysteresis			•
nciSensorFailure	SF	BD	16	bd-17	UNVT_logic	10149	RD/WR		0	2	2	Thermostat function if sensor failure. See SF parameter description	•	•	•
nciSensorOffset	So	ADF	16	adf-17	SNVT_temp_p	105	RD/WR	°C	-20	20	0	Sensor offset	•	•	•
nciAirTempPercent	Pd	ADF	15	adf-16	SNVT_lev_percent	81	RD/WR	%	0	100	0	Virtual temper. weight	•	•	•
nciAlarmAux	AA	DB	13	bd-14	UNVT_sf_function	10158	RD/WR		0	1	0	Programmable digital output. See AA parameter description	•		•
nciLocation					SNVT_str_asc	36	RD/WR		0	255	0	LON address of the specific device	•	•	•
nciMaxSendTime					SNVT_time_sec	107	RD/WR		5	6553	5	Minimum frequency of production of Network Variable Outputs (LON compatibility)	•	•	•
nciMinSendTime					SNVT_time_sec	107	RD/WR		0	6553	0	Present only for LON compatibility but not used			
nciRcvHrtBt					SNVT_time_sec	107	RD/WR		0	6553	0	Receiving heart bit	•	•	•

Accessories

Item Code	Description
TR230/12-1	Transformer 230/12 - 3 VA
A99B-9108	Sensor, cable length: 2mt IP68
LP-RTC05-001C	Plug-in Real Time Card
LP-RTC05-001D	Plug-in Real Time Card, bulk pack 50 pcs
LP-NET051-000C	Plug-in N2Open communication card
LP-NET051-000D	Plug-in N2Open communication card, bulk pack 50 pcs
LP-NET052-001C	Plug-in LON communication card, MR40 profile
LP-NET052-001D	Plug-in LON communication card, MR40 profile, bulk pack 50 pcs

Alarm Codes and Messages

Code	Cause	System Status
F1	Open or shorted room temperature sensor	<ul style="list-style-type: none"> • Alarm output energised (if present) • Compressor output in function of param. SF • Automatic reset
F2	Open or shorted evaporator temperature sensor	<ul style="list-style-type: none"> • Alarm output energised (if present) • Defrost end only by time • Fan managed in parallel to compressor • Automatic reset
A1	General Alarm: Digital input open for longer than param. id and iF = 1	<ul style="list-style-type: none"> • Alarm output energised (if present) • All other outputs go OFF • Automatic reset
A2	Delayed Alarm: Digital input open for longer than param. id and iF = 2	<ul style="list-style-type: none"> • Alarm output energised (if present) • Automatic reset
A3	Door Switch: Digital input open after delay id , and iF = 3	<ul style="list-style-type: none"> • Fan forced OFF immediately • Alarm output energised (if present) • Automatic reset
Hi	Room temperature has reached or exceeded (Setpoint + AH) and delay At elapsed.	<ul style="list-style-type: none"> • Alarm output energised (if present) • Automatic reset
Lo	Room temperature has reached or fallen below (Setpoint + AL) and delay At elapsed.	<ul style="list-style-type: none"> • Alarm output energised (if present) • Compressor output OFF • Automatic reset
EE	Program failure	<ul style="list-style-type: none"> • Replace controller
Fon	iF = 8 and digital input open	<ul style="list-style-type: none"> • Controller in Fan Only Mode. See parameter iF = 8
oFF	iF = 6 and digital input open	<ul style="list-style-type: none"> • Controller in OFF Mode. See parameter iF = 6

Repair and replacement

Field repair is not possible. In case of defective or improperly functioning control, please check with your nearest supplier. When contacting the supplier for replacement, you should state the type-model number of the control. This number can be found on the data plate.

Technical Data

Product	MR40				
Power Requirements	12 Vac/dc $\pm 10\%$; 50/60 Hz				
Power Consumption	2.5 VA				
Protection Class	Front plate	IP 54			
	Rear	IP 20			
Ambient Operating Conditions	-10° to +55 °C (14° to 131°F) 10 to 95 % RH (non condensing)				
Ambient Storage Conditions	-30° to +80 °C (-22° to +176°F) 10 to 95 % RH (non condensing)				
Range	-40 to +70°C				
Display Resolution	$\pm 0.1^\circ\text{C}$ between -9.9°C and $+99.9^\circ\text{C}$				
Control Accuracy	± 0.3 (sensor not included)				
Sensor Cable	2 meters				
Output Ratings	(250Vac)	Compressor	Alarm / AUX	Defrost	Fan
	MR42PM12R-1C	SPDT 8(3)A			
	MR42PM12R-A1C	SPDT 8(3)A	SPST 5(1)A		
	MR43PM12R-2C	SPDT 8(3)A		SPDT 8(3)A	
	MR44PM12R-A2C*	SPDT 8(3)A	SPST 5(1)A	SPDT 8(3)A	SPDT 8(3)A
	* Max. current on common = 20 Amps				
Dimensions (H x W x D)	35 x 75 x 81mm				
CE Compliance	73/23/EEC directive: EN 60730 89/336/EEC directive: EN 50081-1, EN 50082-2				

The performance specifications are nominal and conform to acceptable industry standards. For applications at conditions beyond these specifications, consult the local Johnson Controls office or representative. Johnson Controls shall not be liable for damages resulting from misapplication or misuse of its products. This document is subject to change without prior notice.



Controls Group
507 E. Michigan Street
P.O. Box 423
Milwaukee, WI 53201

www.johnsoncontrols.com

MS Electronic Controls for general purpose and multi stages controls

/ntroduction

This range of versatile controls is intended for single or multistage (2 or 4 stages) applications such as heating, cooling but also humidity or pressure depending on the input type.

This range incorporates all control functions as required by modern applications and it exists in both panel mount and DIN rail enclosures. Particular attention has been given to its style in order to better suit your machine design.

This complete range of microprocessor based controls offers innovative features and "state of the art" technology.



Panel and DIN Rail Models

Features and Benefits	
<input type="checkbox"/> Attractive Panel mount and DIN rail mount enclosure	Easy and quick installation
<input type="checkbox"/> Up to 4 relays in panel mount enclosure	Reduced space
<input type="checkbox"/> 230 Volt power supply models available	Reduced installation time
<input type="checkbox"/> Accept A99 and 0-10 Volts sensor signal depending on models	Opens a wide range of potential applications
<input type="checkbox"/> Power supply to sensors on 0-10 Volts models available from controller	Reduced wiring
<input type="checkbox"/> Accurate and interchangeable IP 68 sensor	Accurate control performance No recalibration needed
<input type="checkbox"/> Wide range of enclosures for sensors available	Possibility to match a wide variety of temperature sensing needs
<input type="checkbox"/> Keyboard lock	Avoids accidental tampering by personnel
<input type="checkbox"/> SMD technology	Higher quality and reliable components

Features

Display

The display has 3 LED digits with +/- indication and accepts a temperature range from -40 to 70 °C (-40 to 158 °F) with a precision of 1 °C or F. When used with a 0-10 Volts signal, the displayed value can be configured from -40 to 100.

Sensor input

This range of controllers uses Johnson Controls A99 temperature sensor. Its accuracy is within 0.5 °C between -15 and 75 °C. Its tolerance increases at temperatures outside this range, as shown below.

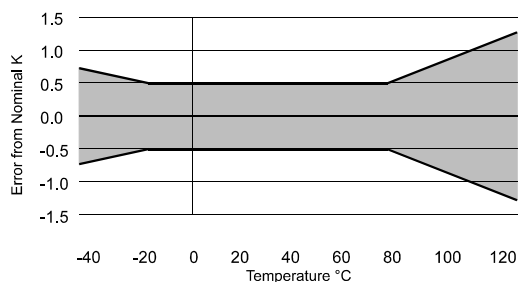

Its gas tight packaging makes it the best sensor for refrigeration applications. *For details please refer to A99 documentation.* An offset of the measured temperature can be configured for temperature compensation or cable extension.

One stage and two stages controls are also available with a 0-10 Volts input making it compatible with a wide variety of standard sensors, and among others it can be used with HT9 humidity sensors and P99 pressure sensors from Johnson Controls. *For details please refer to HT9 and P99 documentation.* A 12 Volts dc signal is available from the controller in order to power the sensor. Both with temperature and voltage input, controllers allow an offset of the measured value that can be used for compensation.

Adjustable setpoint limits

The setpoint range can be limited in order to avoid "too high" or "too low" setpoint setting of the equipment. The final user cannot set a setpoint value exceeding these limits.

Function mode

A special mode allows you to select the type of action you require. Direct or reverse (respectively cooling or heating, dehumidifying or humidifying, etc...). Pre-set functions have been programmed for you, avoiding possible mistakes of stages crossing. Furthermore, the configuration of this parameter is in a different table than other parameters preventing from final user to alter the defined control strategy.

Anti short cycle protection

In order to protect your equipment, all models have two built-in anti short cycles. The first one is dedicated to cooling stages while the second is used for heating stages. This allows you to use this features only when required.

Keyboard locking

A sequence of key strokes allows you to disable/enable modification of the internal parameters. This prevents unauthorised personnel from making parameter modifications.

Soft start

When switching on your equipment, the process variable might be very different from your setpoint, and a full load might be incompatible with your process. In this case, the controller allows to increase the setpoint degree per degree at a predefined rate (in degree per minutes).

Self-testing procedure

This feature helps you to check the installation and configuration of the controller once installed. After a key stroke sequence $\nabla + \blacktriangle$, it will cycle all outputs and flash all LEDs.

Alarm management

All devices include a high and low limit alarm. This alarm is related to the main setpoint of the controller and displays "Hi" or "Lo" in case of exceeding those limits. A delay can be configured in order to prevent non significant events from triggering the alarm. The differential of the alarm is also adjustable.

Events such as a disconnected or short circuited sensor will be detected, signalled and will results in the shut OFF of the installation.

Display updating time

This is very handy to avoid displaying intermittent changes of process variable. It provides an adjustable time delay till the display is "refreshed".

Units

Units can be selected from degree Celsius or Fahrenheit.

Configuration

Available keys	Action
Up	Check 2 nd sensor value (if applicable) and DI status. Scroll parameters, change values
Down	Check DI status and 2 nd sensor value (if applicable). Scroll parameters, change values
SET for 3" < t < 7"	Go to setpoint setting
SET for 7" < t < 15"	Go to parameters setting
SET+DN for t > 7"	Mode selection
UP+DN for t > 5"	Self test
SET+UP+DN for t > 10"	Lock/Unlock keyboard

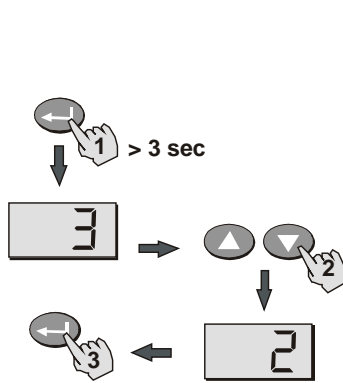

Set point

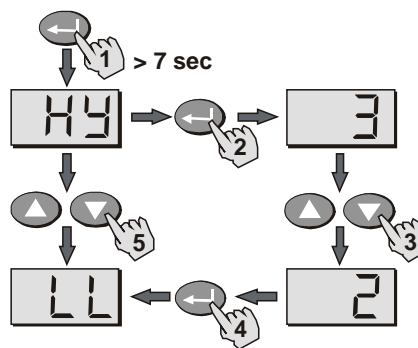

Parameters

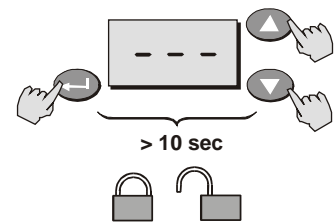

Keyboard Lock / Unlock

Dimensions (in mm)

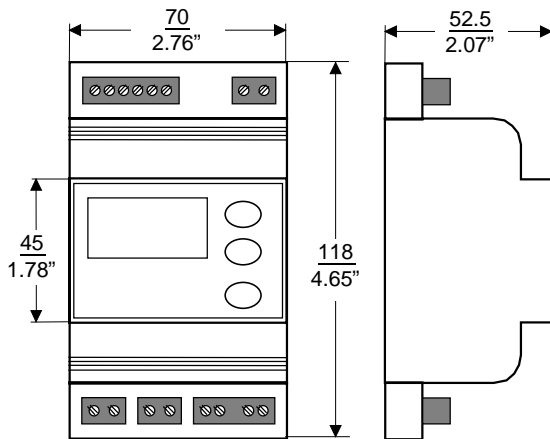

DIN Rail enclosure

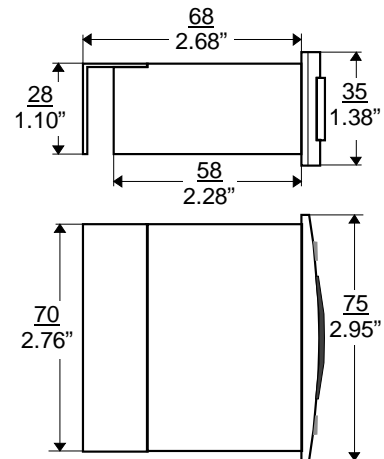

Panel cut-out for panel mount versions

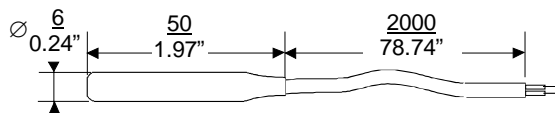

A99BB-200C Sensor

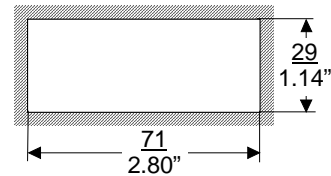

Panel cut-out for panel mount versions

Wiring Instruction

WARNING

When wiring and servicing make sure that:

- the electric supply to the actuator is switched off to avoid possible damage to the equipment, personal injury or shock.
- you do not touch or attempt to connect or disconnect wires when electric power is on.

Note

These controls are intended to control equipment under normal operating conditions. Where failure or malfunction of the controls could lead to an abnormal operating condition that could cause personal injury or damage to the equipment or other property, other devices (limit or safety controls) or systems (alarm or supervisory systems) intended to warn of or protect against failure or malfunction of the controls must be incorporated into and maintained as part of the control system.

Display

These devices are to display temperature and humidity:

Description

Through a switch selection, you can select the range in °C and °F. Separate models are available to display %. In case of a 0-10 Volts input type, the power supply to the sensor is available from the controller (12 Volts dc).

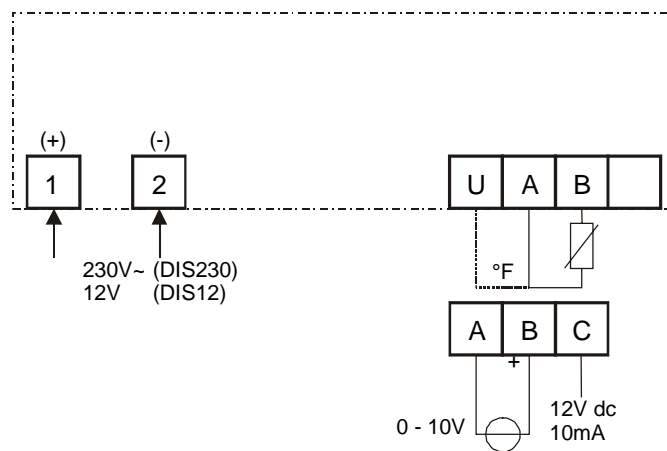

Display DIS

Selection table

Item code	Enclosure	Power supply	Input type	Shipping weight
DIS12T-1C	Panel 75x35	12 Vac/dc	A99, sensor included, 2m	200 g
DIS230T-1C	Panel 75x35	230 Vac	A99, sensor included, 2m	260 g
DIS12V-1C	Panel 75x35	12 Vac	0 to 10 V, no sensor	160 g
DIS230V-1C	Panel 75x35	230 Vac	0 to 10 V, no sensor	220 g

One stage controls - MS1

This device is designed to control one stage applications which can be in the following configuration:

- One direct stage (cooling, dehumidifying,...).
- One reverse stage (heating, humidifying....).

Description

The output is equipped with a SPST or SPDT relay capable of driving units up to 16(12) Amps. It also features, in its standard version, a low power output dedicated for alarm signalling sufficient to drive an LED, a 24 V light bulb or a buzzer.

Note: A detailed list of available parameters and their description can be found at the end of this documentation.

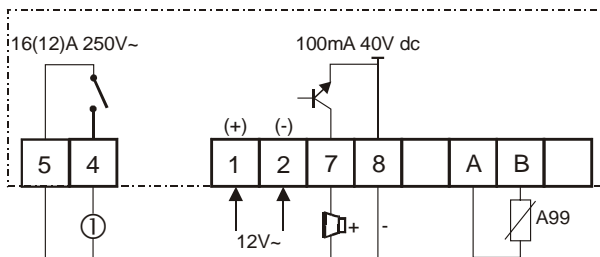

Wiring diagram a)

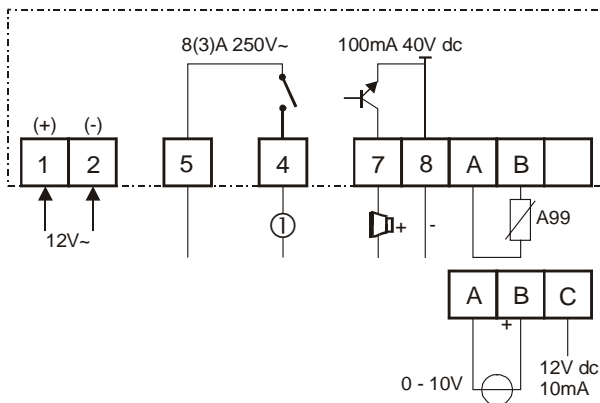

Wiring diagram b)

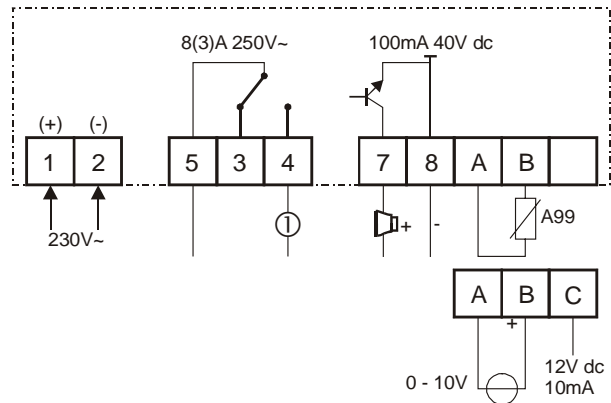

Wiring diagram c)

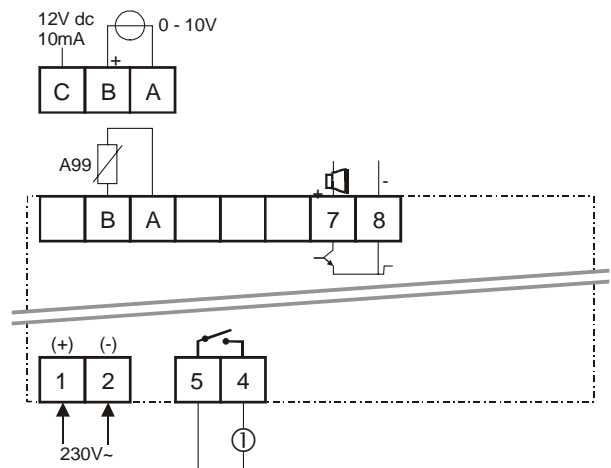

Wiring diagram d)

Selection table:

Item code	Enclosure	Power supply	Input type	Shipping weight	Wiring diagram
MS1PM12RT-1C	Panel 75x35	12 Vac/dc	A99	230 g	a)
MS1PM230T-1C	Panel 75x35	230 Vac	A99	300 g	c)
MS21PM12RT-1C	Panel 75x35	12 Vac	A99	230 g	b)
MS1DR230T-1C	DIN Rail	230 Vac	A99	340 g	d)
MS1PM12RV-1C	Panel 75x35	12 Vac	0-10 Volts	180 g	a)
MS1PM230V-1C	Panel 75x35	230 Vac	0-10 Volts	240 g	c)
MS1DR230V-1C	DIN Rail	230 Vac	0-10 Volts	290 g	d)

Note: Models with an A99 temperature input have a temperature sensor included

Two stages controls – MS2

This device is specifically designed for the control of two stages applications which can be in the following configuration:

- Two direct stages (cooling, dehumidifying,...) with common setpoint.
- Two reverse stages (heating, humidifying...) with common setpoint.
- Two stages with deadband, direct / reverse stage (heating/cooling, humidifying/dehumidifying..) with one setpoint.
- Two independent stages, one direct / one reverse, (heating/cooling, humidifying/dehumidifying..) with two setpoints.

Digital input functions

All controllers are equipped with an additional digital input. This input can perform the following functions:

- External alarm : If the input is open for a time longer than preset, all output goes OFF and an alarm message is displayed.
- Night setback: The setpoint are shifted of a preset value in order to save energy.
- Remote shut-OFF: In this case all output are shut-OFF and the display shows "OF". Key on the keypad.

Note: A detailed list of available parameters and their description can be found at the end of this documentation

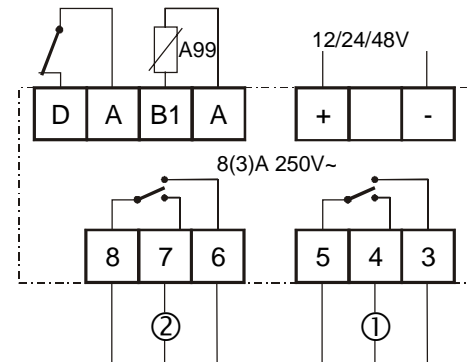

Wiring b)

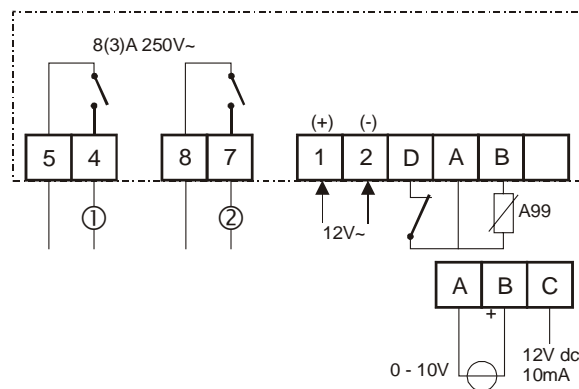

Wiring a)

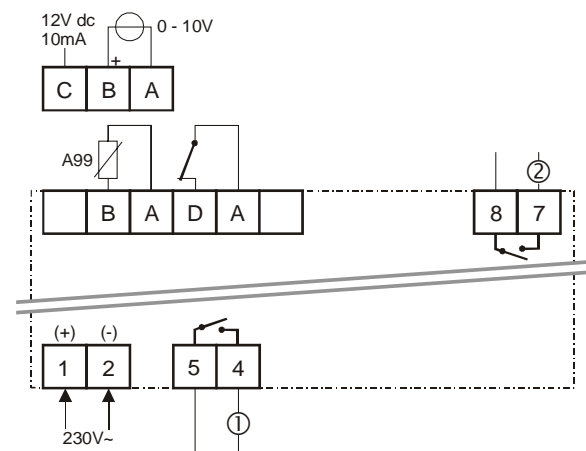

Wiring c)

Selection table

Item code	Enclosure	Power supply	Input type	Shipping weight	Wiring diagram
MS2PM12RT-1C	Panel 75x35	12 Vac/dc	A99	240 g	a)
MS2DR230T-1C	DIN Rail	230 Vac	A99	360 g	c)
MS2DR48DT-1C	DIN Rail	12-24 Vac/dc 48Vdc	A99	300 g	b)
MS2PM12RV-1C	Panel 75x35	12 Vac	0-10 Volts	180 g	a)
MS2DR230V-1C	DIN Rail	230 Vac	0-10 Volts	300 g	c)

Note: Models with an A99 temperature input have a temperature sensor included

Four stages controls – MS4

This control is specifically designed for the control of four stages temperature applications which can be in the following configuration:

- Four cooling stages with common setpoint.
- Four heating stages with common setpoint.
- Four stages with deadband, two heating stages / two cooling stages with common setpoint.
- Two independent sets of two dependent stages, two heating stages / two cooling stages

This control can be equipped with two sensors, one for the ambience and one for the outdoor. In this case it can perform energy saving functions by outdoor temperature compensation.

Digital input functions

All controllers are equipped with an additional digital input. This input can perform the following functions:

- External alarm: If the input is open for a longer time than preset, all output goes OFF and an alarm message is displayed.
- Night setback: The setpoint are shifted of a preset value in order to save energy.
- Remote shut-OFF: In this case all output are shut-OFF and the display shows "OF".

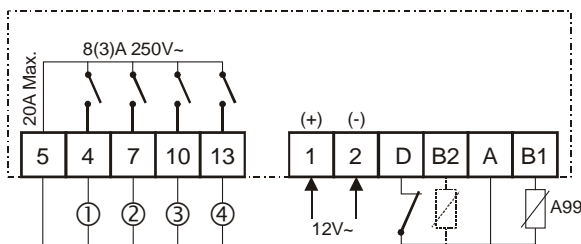

Wiring a)

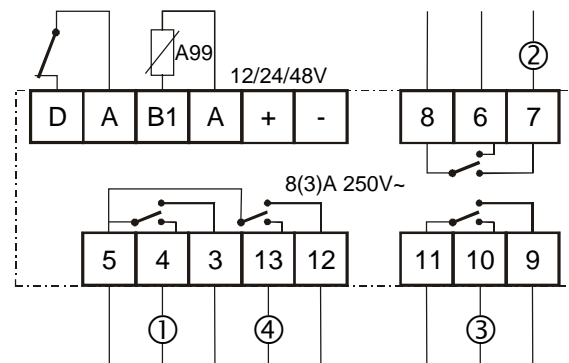

Wiring b)

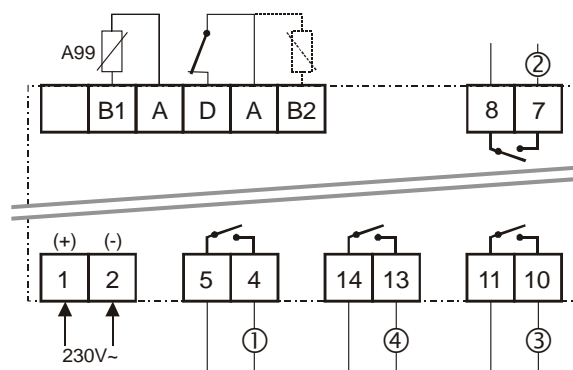

Wiring c)

Outdoor temperature compensation

This function is activated and configurable only when the second sensor is connected.

In this case, the controls perform a setpoint compensation based on the difference between outdoor temperature and the setpoint. You just need to fix the non compensated band, the heating and cooling compensation gain .

Note: A detailed list of available parameters and their description can be found at the end of this documentation.

Selection table:

Item code	Enclosure	Power supply	Input type	Shipping weight	Wiring diagram
MS4PM12RT-1C	Panel 75x35	12 Vac/dc	A99	270 g	a)
MS4DR230T-1C	DIN Rail	230 Vac	A99	400 g	b)
MS4DR48DT-1C	DIN Rail	12-24 Vac/dc 48Vdc	A99	400 g	c)

Note: Models have one temperature sensor included

Description of each parameter

Action modes:

This family of controllers allow the following type of predefined action modes:

One stage models MS1 and MSx1

One stage direct (1d)

One stage reverse (1r)

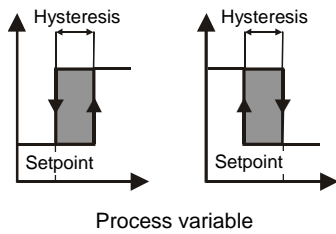

Process variable

Two stages models MS2

Two stages direct (2d)

Two stages reverse (2r)

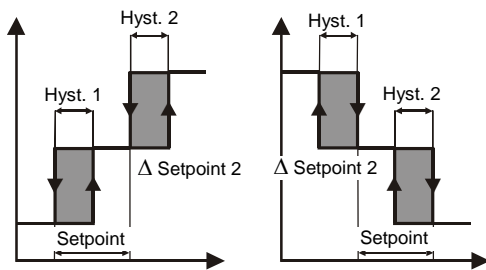

Process variable

Two independent stages (2i)

Two independent stages (2b)

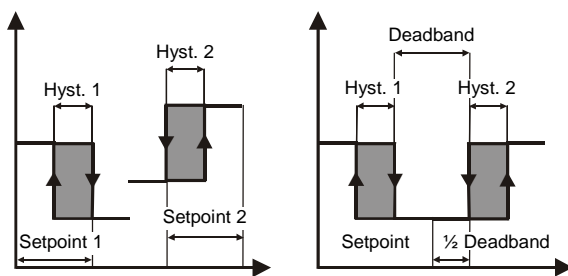

Process variable

Four stages models MS4

Four stages cooling (4d)

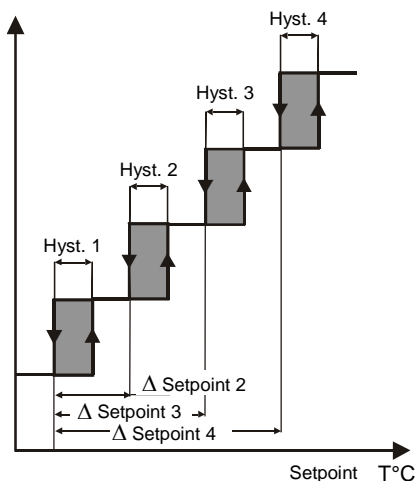

Setpoint T°C

Four stages heating (4r)

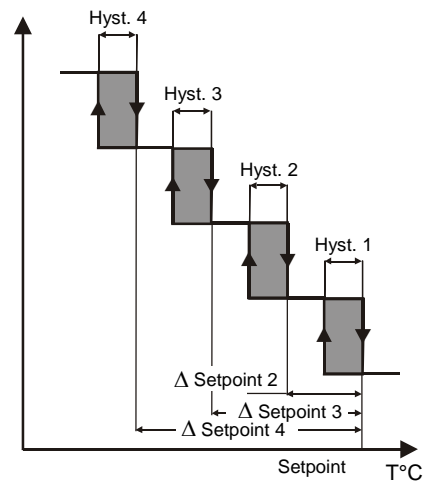

Setpoint T°C

Four stages with deadband (4b)

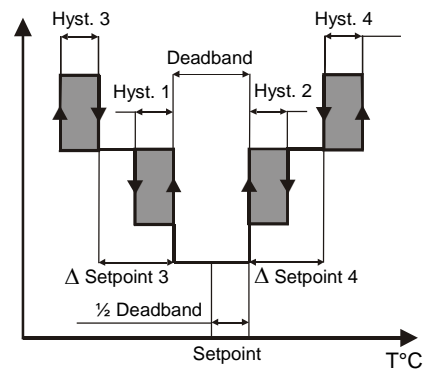

Setpoint T°C

Four independent stages (2 x 2) (4i)

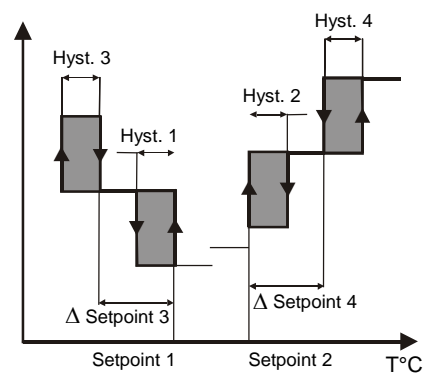

Setpoint 1 Setpoint 2 T°C

Description of each parameter

Setpoint

Definition depends on the action mode.
Please refer to the diagrams at the previous pages.

Hy1 Hysteresis

This is the difference between the value at which the output is switched OFF and the value at which the output is switched ON. This is an absolute value, related to the setpoint.

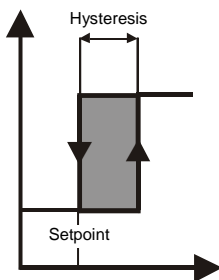

Example:
Cooling Setpoint = 6 °C
Hysteresis = 2 K
The compressor is switched ON when the temperature goes over 8 °C, and is turned OFF when the temperature decreases to 6 °C.

S2 Δ Setpoint 2

Switch OFF of output 2. Depending of the action mode it will have different meaning:
Mode 2d, 2r, 4d and 4r: differential to stage 1
Mode 2b and 4b: deadband
Mode 2i and 4i: independent setpoint 2

Hy2 Hysteresis

This is the difference between the value at which the output is switched OFF and the value at which the output is switched ON. This is an absolute value, related to the setpoint.

S3 Δ Setpoint 3

This is the differential between stage 3 and stage 1.

Hy3 Hysteresis

This is the difference between the value at which the output is switched OFF and the value at which the output is switched ON. This is an absolute value, related to the setpoint.

S4 Δ Setpoint 4

This is the differential between stage depending on the model, it refers to different setpoint:
Mode 4d and 4r: differential to stage 1
Mode 4b and 4i: differential to stage 2

Hy4 Hysteresis

This is the difference between the value at which the output is switched OFF and the value at which the output is switched ON. This is an absolute value, related to the setpoint.

LL/HL Lower & Upper setpoint limit

The setpoint value cannot be adjusted outside the limits defined by these parameters, to avoid improper setpoint setting by the user.

CC Anti short cycle protection, cooling

This parameter prevents the compressor from being turned ON / OFF too often. The value that you set is the minimum time between two subsequent switches ON of the output. It will be effective only on direct acting stages (i.e. cooling).

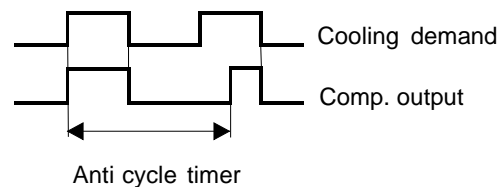

CH Anti short cycle protection, heating

Identical to the previous parameter but effective only on reverse acting stages (i.e. heating). This combination allows you to have a protection on stages driven by compressors and none on electrical coil stages.

rT Soft start

Allows you to increase or decrease the setpoint according to a time rate. The unit is minutes/units, in case of temperature input signal, it would be minutes/°C

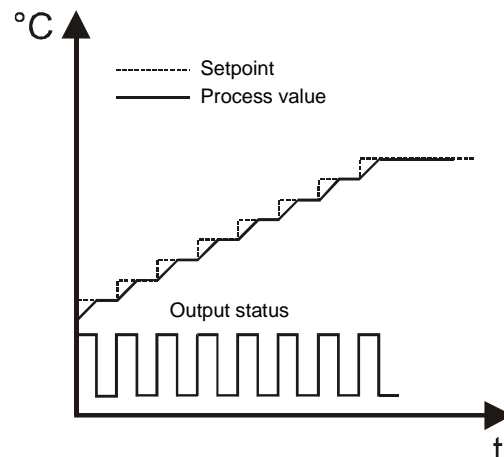

AH Maximum alarm

High alarm value relative to setpoint. If your setpoint is at 50% RH and you want an alarm 40% above setpoint, it will be triggered at 90%.

AL Minimum alarm

Low alarm value relative to setpoint. If your set point is at 6°C and you want an alarm 5 K below setpoint, it will be triggered at 1°C.

Ad Alarm differential

Useful to avoid alarm oscillation.

For example:

Setpoint = 6 °C

Max. temperature alarm = 5 K

Alarm differential = 2 K

In this case, when the cold room temperature goes over $6 + 5 = 11$ °C for a time greater than parameter 16 the alarm is activated; when temperature returns below $6 + 5 - 2 = 9$ °C the alarm is reset.

At Alarm time delay

Delay between the detection of the alarm and the activation of the alarm sequences. This is useful to prevent temporary conditions from causing an alarm. Furthermore, the controller automatically ignores the alarm condition "for 20 minutes after the power-ON".

So Sensor offset

This value is added to or subtracted from the measured value to compensate for possible field measurement offset errors. With the A99 sensor, to compensate for extra long copper cabling use the following formula:

$$\text{Compensation} = -\frac{5 \times \text{length}}{1000 \times \text{area}} \text{ K, where}$$

length = length of the cable in meters
area = section of the cable in millimetres and compensate for the calculated value.

Un Temperature units

(apply only to models with an A99 input)

0 = Celsius degrees,

1 = Fahrenheit degrees.

PU Display updating time delay

The process value display will be refreshed with this defined period. It will not affect the control performance.

iF Digital input function

The digital input (normally closed) can be configured according to the plant requirements:

0 = the DI is not connected

1 = If the contact is open for more a time longer than that set through parameter 22, the plant is switched OFF and an alarm message is displayed

2 = Stand-by bias. When the contact is open the setpoint(s) are shifted of the value set in parameter 21. Reverse setpoints (heating, humidifying) are decreased, direct setpoints (cooling, dehumidifying) are increased.

3 = Remote shut-off of the plant. When the contact is open, the plant is stopped.

Sb Stand-by bias

Value of the setpoint shift when the Digital input is open and configuration of parameter 20 = 2

Id Digital input time delay

Time between the detection of the digital input opening and the enabling of the function selected through parameter 20.

The following parameters are dedicated to temperature compensation and are available only when the second temperature sensor (AI2) is connected.

The compensation can only perform energy saving type and is calculated based on the difference between external temperature and setpoint. Its parameters are the following

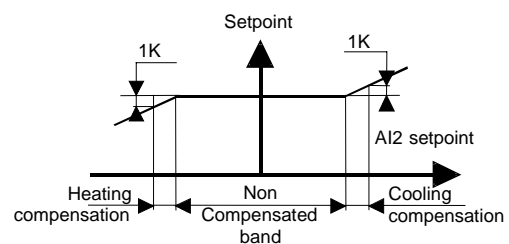
**Lc Non compensated band**

This is the band of temperature difference (outside temperature - setpoint) where no compensation is performed.

Uc Heating compensation

This is the decreasing rate of compensation when: (outside temperature - setpoint) gets below half of the non compensated band. It is given in Kelvin / Kelvin (Amount of outside temperature decrease to reduce the setpoint by 1K)

nc Cooling compensation

This is the increasing rate of compensation when: (outside temperature - setpoint) gets above half of the non compensated band. It is given in Kelvin / Kelvin (Amount of outside temperature increase to increase the setpoint by 1K)

IS Interstage delay

This is the time delay between switching ON of 2 or more successive stages. It prevents a high inrush current when there is a request for cooling or heating and more stages should switch ON simultaneously. It is active between stages of the same type (i.e. cooling stages) and is only active during switch ON.

Lr Low range analog input 1

(apply only to models with 0 to 10 Volt input). This is the value at 0.0 Volt dc when input 1 is used with 0-10 Volts signal.

Hr High range analog input 1

(apply only to models with 0 to 10 Volt input). This is the value at 10.0 Volt dc when input 1 is used with 0-10 Volts signal.

Parameters

	Parameter	Setting Range	Default	MS1 MSx1	MS2	MS4
Temperature control parameters						
H1	Hysteresis (HY)	1 to 9 K	2	•	•	•
S2	Δ Setpoint 2	Direct/Reverse = 1 to 40 units Deadband = 2 to 40 units Indip. setpoint = Low to high limit	3		•	•
H2	Hysteresis (HY)	1 to 9 K	-40		•	•
S3	Δ Setpoint 3	1 to 40 units	-40			•
H3	Hysteresis (HY)	1 to 9 K	-40			•
S4	Δ Setpoint 4	1 to 40 units	-40			•
H4	Hysteresis (HY)	1 to 9 K	-40			•
LL	Lower setpoint limit (LL)	-40°C to higher limit	-40	•	•	•
HL	Higher setpoint limit (HL)	lower limit to 125 units	70	•	•	•
CC	Anti short cycling cooling (CC)	0 to 9 min	2	•	•	•
CH	Anti short cycling heating (CH)	0 to 99 min	60	•	•	•
rt	Soft start	0 to 99 min / units	3	•	•	•
Alarm parameters						
AH	High. temperature alarm	0 to 50 units related to setpoint	10	•	•	•
AL	Low temperature alarm	-50 to 0 units related to setpoint	-10	•	•	•
Ad	Alarm differential	1 to 9 units	1	•	•	•
At	Alarm time delay	0 to 99 min	30	•	•	•
Temperature parameters						
Lc	Non compensated band	0 to 20 K	OF			•
Uc	Heating compensation	0 to 6 K/K	0			•
nc	Cooling compensation	0 to 6 K/K	20			•
Other parameters						
So	Sensor offset	-20 to +20 units	0	•	•	•
Un	Temperature units	0 = Celsius degrees 1 = Fahrenheit degrees	0	•	•	•
PU	Display updating time delay	1 to 99 sec	7	•	•	•
iF	Digital input function	0 = Not used 1 = Shut off and alarm signalling 2 = Stand by mode 3 = Remote switch off	6		•	•
Sb	Stand-by bias	0 to 20 units	40		•	•
Id	Digital input time delay	0 to 99 sec	5		•	•
IS	Interstage delay	3 to 99 sec	20		•	•
Lr	Low range analog input 1	-40 to high range	20	•	•	
Hr	High range analog input 1	Low range to 100	20	•	•	

* When there are 2 setpoints (MS2 or MS4 is configured for independent setpoint mode), the low alarm is linked to the lowest setpoint and the high alarm is linked to the highest setpoint.

Accessories

Item Code	Description
TR230/12-1	Transformer 230 / 12,3 VA
A99BB-200C	Sensor, cable length: 2m

For humidity or pressure sensors refer to HT9 or P99 Product Data Sheets.

Repair and replacement

Field repair is not possible. In case of defective or improperly functioning control, please check with your nearest supplier. When contacting the supplier for replacement, you should state the type-model number of the control. This number can be found on the data plate.

Notes

Specifications

Power Requirements	12 Vac/dc $\pm 10\%$ (Models with 0 to 10 V input 12 Vac $\pm 10\%$) 230 Vac $\pm 10\%$ (only MSxDR48DT) 12-24 Vac/dc $\pm 10\%$ – 48 Vdc $\pm 10\%$	Not all power supplies are available in every version. Please refer to selection tables.			
Frequency	50/60 Hz				
Power consumption	DIS : 1.5 VA MS : 2 VA				
Protection Class	Panel mount	Front panel	IP 54		
		Rear	IP 20		
	DIN rail	IP 20			
Ambient Operating Conditions	-10° to +55 °C (14° to 131 °F)				
Range	0 to 95 % RH (non condensing)				
	-40 to +70 °C -40 to 100 when 0-10 Volts input				
Accuracy & Precision	± 1 unit				
Sensor cable	2 meters with temperature input None when 0 to 10 Volt input				
Output ratings (250V ac)	Stage 1	Stage 2	Stage 3 & 4	Alarm	
MS1PM12	SPST 8(3)A			o.c(*)	
MS21PM12	SPST 16(12)A			o.c(*)	
MS1PM230	SPDT 8(3)A			o.c(*)	
MS1DR230	SPST 8(3)A			o.c(*)	
MS2PM12	SPST 8(3)A	SPST 8(3)A			
MS2DR48	SPDT 8(3)A	SPDT 8(3)A			
MS2DR230	SPST 8(3)A	SPST 8(3)A			
MS4PM12RT-1C	SPST 8(3)A	SPST 8(3)A	SPST 8(3)A		
MS4DR230T-1C	SPST 8(3)A	SPST 8(3)A	SPST 8(3)A		
MS4DR48DT	SPDT 8(3)A	SPDT 8(3)A	SPDT 8(3)A		
(*) Open collector:	40 Vdc/100 mA				
Dimensions (H x W x D)	Panel mount	35 x 75 x 68 (1.38" x 2.95" x 2.68")			
	DIN rail	118 x 70 x 52.5 (4.65" x 2.76" x 2.07")			
CE Compliance	73/23/EEC directive: EN60730 89/336/EEC directive: EN50082-1 EN50082-2				

The performance specifications are nominal and conform to acceptable industry standards. For applications at conditions beyond these specifications, consult the local Johnson Controls office or representative. Johnson Controls shall not be liable for damages resulting from misapplication or misuse of its products. This document is subject to change without prior notice.

**JOHNSON
CONTROLS**

Johnson Controls International, Inc.

Headquarters: Milwaukee, WI, USA
 European Headquarters: Westendhof 8, 45143 Essen, Germany
 European Factories: Lomagna (Italy), Leeuwarden (The Netherlands), Essen (Germany)
 Branch Offices: Principal European Cities.
 This document is subject to change without notice

System 27 NOVA

Modular Electronic Temperature Control System

Introduction

System 27 NOVA is a family of modern modular electronic modules designed for a wide variety of control configurations in refrigeration, heating, ventilation, air-conditioning and other related fields.

The temperature control modules can be used as a stand alone device or together with other modules, such as, stage modules, display modules, time switch modules, etc., to achieve a diverse number of single or multistage applications.

Typical applications are:

- refrigerated/freezer display cases
- beverage coolers
- liquid chillers
- cold-room storage.

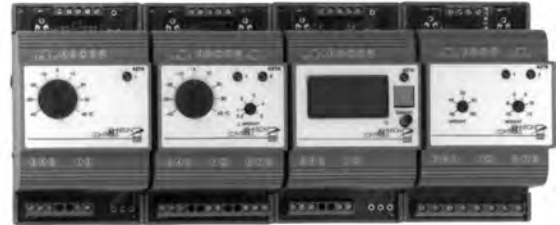

**System 27 NOVA Modular
Temperature Controls**

Description

The modular concept was specially designed to make control configuration easier and still offer the flexibility necessary to answer the many individual control requirements encountered today.

Feature and Benefits

<input type="checkbox"/> Modular design	Provides the flexibility to realise the required control set up without redundancy and makes future expansion easy.
<input type="checkbox"/> “Plug-in” quick connector wiring system	Eliminates wiring between modules and reduces installation cost.
<input type="checkbox"/> Adjustable differential and heating/cooling setting	Provides flexibility to match any combination of heating or cooling applications.
<input type="checkbox"/> Wide range of enclosures for sensing elements	Matches various applications.
<input type="checkbox"/> Attractive DIN-rail mount housing	Easy and quick to install.
<input type="checkbox"/> Setpoint shift output function	Modules can be used for “multiple setpoint” applications.

The System 27 NOVA family includes the following modules:

A27 Temperature Control Modules



These one- or two-stage temperature control modules can be used as a low cost control for stand alone applications, or as the primary control module for multiple stage applications. For this type of applications one or more stage modules can be connected to the

control module (thermostat) very easy by using the quick connector system. Four types of temperature control modules are available:

- * One- or two-stage thermostats
- * Differential thermostat:
Responds to the difference of two temperature inputs.
- * Frost protection thermostat:
Senses low temperature and sensor failure.

S27 Stage Modules



If multi-stage control is required one or more stage modules can be hooked up easily to an A27 temperature control module, simply by using the included quick connector. There are two types of stage modules available:

- * modules with their stage setpoint linked to the thermostat setpoint. The stage setpoint can be set for the number of degrees of offset of the A27 temperature control module setpoint.
- * modules with independent setpoint setting. These modules act as a thermostat but no additional sensor is required.

D27A Temperature Display Modules



A display module connected to a temperature control module gives a digital indication of the measured temperature or setpoint. It is also possible to connect a sensor directly to the D27A for thermometer function. Three types of display modules are available:

- * The DIN Rail mount display can be connected to a thermostat very easy by using the quick connector system.

- * The Panelmount display can be used in any application where remote reading of the temperature is required.
- * The Panelmount display/selector permits to read out up to 5 temperatures obtained from either a sensor or a thermostat or a combination



Y27L Signal Converter



This module converts a temperature input signal to a standardised output signal of 0 to 10 or 4 to 20 mA. The input signal can either be obtained from a temperature sensor or a temperature control module. The signal converter can be used for those applications where an

analogue output is required. Such as; to a motor, motor actuated valve, recorder etc.

A99 Temperature Sensor



A wide variety of sensors is available to cover a large variety of applications. Please refer to the A99 temperature sensor bulletin.

Note

The System 27 modules are intended to control equipment under normal operating conditions. Where failure or malfunction of the modules could lead to an abnormal operating condition that could cause personal injury or damage to the equipment or other property, other devices (limit or safety controls) or systems (alarm or supervisory systems) intended to warn of or protect against failure or malfunction of the modules must be incorporated into and maintained as part of the control system.

Application examples

At page 7 and 8 you will find some application examples. For more detailed information about wiring and adjustment, reference should be made to the installation sheets or application notes.

Repair and Replacement

Repair is not possible. In case of an improperly functioning control, please check with your nearest supplier.

When contacting the supplier for a replacement you should state the type-model number of the control. This number can be found on the dataplate.

Accessories dim. in mm

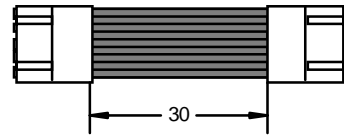

Fig. 1

WRE027N600

Quick Connector for connecting System 27 NOVA modules.

Dimensions (mm)

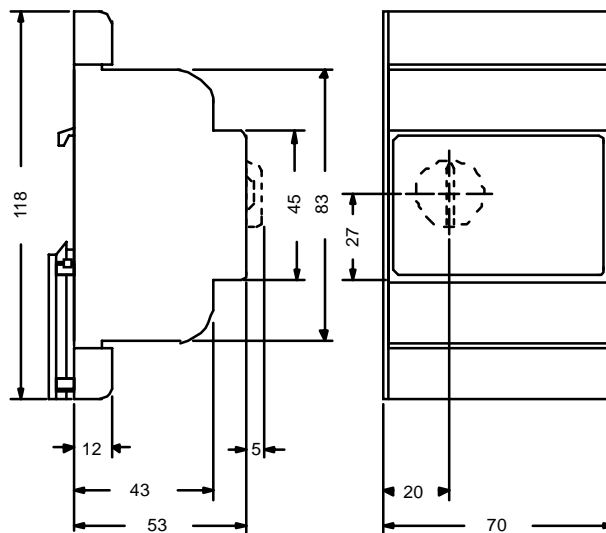

Fig. 3

System 27 NOVA Modules

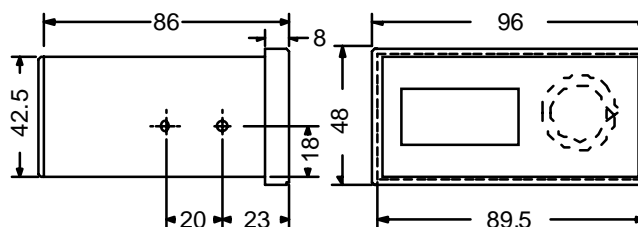

Fig. 4

Panelmount Display and Display/Selector Module

Type Number Selection Table

A27 Temperature Control Modules

One Stage Thermostat

Order number	Power supply	Setpoint range (°C)	Additional
A27A1N11	24 V ac/dc	-40 to +40	* Mode: field adjustable * Differential: 0.5 to 15K * SPDT contact 10(5)A 250 V ac * Setpoint shift: 0 to 10 K
A27A1N12	24 V ac/dc	10 to 100	
A27A2N11	230 V ac	-40 to +40	
A27A2N12	230 V ac	10 to 100	
A27A2N14	230 V ac	0 to 30	
A27A2N15	230 V ac	-20 to +60	

Two Stage Thermostat

Order number	Power supply	Setpoint range (°C)	Additional features
A27A1N21	24 V ac/dc	-40 to +40	* Mode: field adjustable * Differential: 0.5 to 5K * 2x SPDT contact 10(5)A 250V ac * Setpoint shift: 0 to 10 K * Δ Setpoint: 0.5 to 5 K (A27AxN251: 0.5 to 20 K)
A27A1N22	24 V ac/dc	10 to 100	
A27A1N251	24 V ac/dc	-20 to +60	
A27A2N21	230 V ac	-40 to +40	
A27A2N22	230 V ac	10 to 100	
A27A2N25	230 V ac	-20 to +60	
A27A2N251	230 V ac	-20 to +60	
A27A2N26	230 V ac	20 to 60	
A27A2N27	230 V ac	-20 to +20	

Differential Thermostat

Order number	Power supply	Setpoint range (K)	Additional features
A27D1N11	24 V ac/dc	0 to 10	* Hysteresis: 0.5 to 10 K * SPDT contact 10 (5) A 250 V ac
A27D2N11	230 V ac	0 to 10	
A27D2N12	230 V ac	0 to 20	

Frost Protection Thermostat

Order number	Power Supply	Setpoint range (°C)	Man./Auto.	Additional features
A27M2N11	230 V ac	-10 to +5	Man. reset	* Differential 1 K fixed * SPDT contact 10 (5) A 250 V ac
A27F1N11	24 V ac/dc	-10 to +5	Auto. reset	
A27F2N11	230 V ac	-10 to +5	Auto. reset	

S27A Stage Modules

Stage module with stage setpoint related to thermostat setpoint

Order number	Power supply	Setpoint range (K)	Additional features
S27A1	24 V ac/dc	0.5 to 15	* Mode: field adjustable * Differential: 0.5 to 5K * 2x SPDT contact 10(5)A 250V ac * No additional sensor required * Quick connector included
S27A2	230 V ac	0.5 to 15	

Stage module with independent stage setpoint

Order number	Power supply	Number of outputs	Additional features
S27A3	230 V ac	1	* Mode: field adjustable * No additional sensor required * Quick connector included * Setpoint range -20 to +60 °C
S27A4	230 V ac	2	
S27A5	24 V ac/dc	1	

D27A Temperature/Display Modules

D27A Temperature Display Modules DIN rail mount

Order number	Power supply	Display range (°C)	Quick connector included	Additional features
D27A1N1	24 V ac	-40 to +99	no	* Can be used as a stand alone display or in conjunction with temperature control modules * Setpoint read out
D27A2N1	230 V ac	-40 to +99	no	
D27A2N1Q	230 V ac	-40 to +99	yes	

D27A Temperature Display Modules Panel mount

Order number	Power supply	With selector	Additional features
D27AF-9100	230 V ac	no	* Display range -40 to +99 °C
D27AG-9100	230 V ac	yes	* Display/selector reads out up to 5 temperatures

Y27L Signal Converter

Order number	Power supply	Setpoint range °C	Span range °C
Y27L1	24 V ac	-50 to 100	2 to 200
Y27L2	230 V ac	-50 to 100	2 to 200

Wiring & Adjustments

One-stage Thermostat A27AxN1x

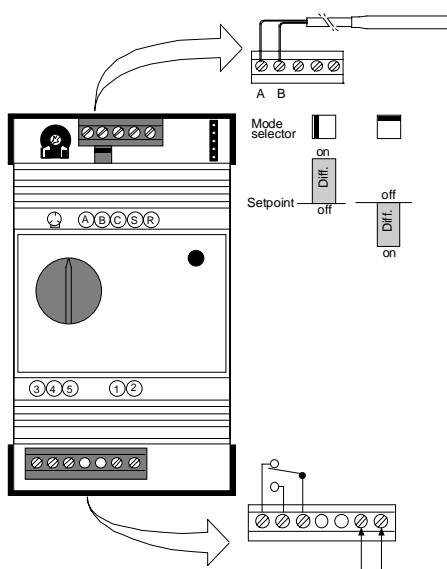

Two-stage Thermostat A27AxN2x

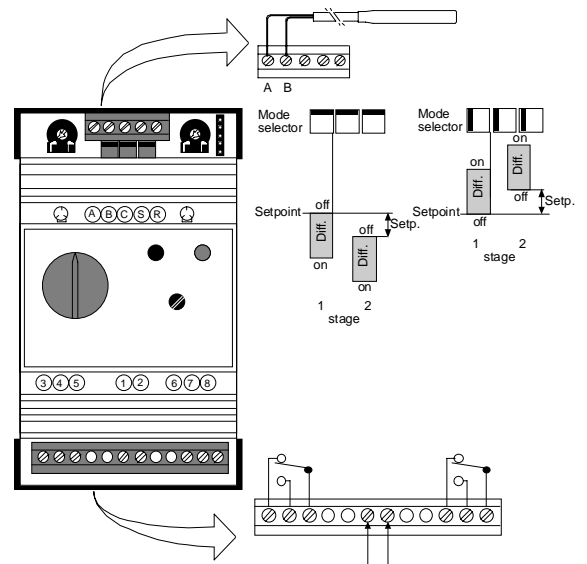

**Single Stage Module
S27A3/S27A5**

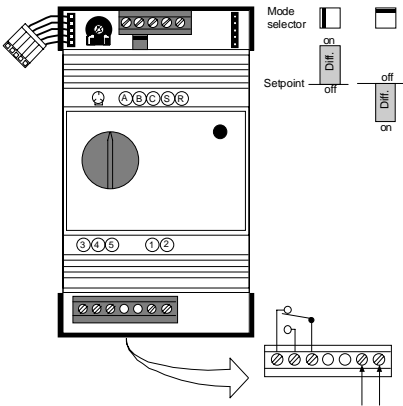

**Protection Thermostat
A27FxN11
A27MxN11**

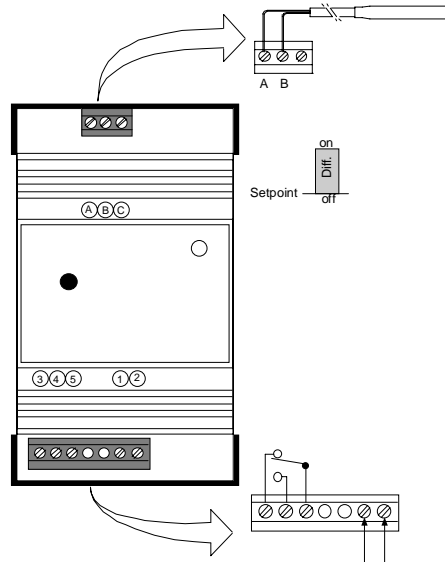

**Stage Module with stage setpoint
related to thermostat setpoint
S27A1/S27A2**

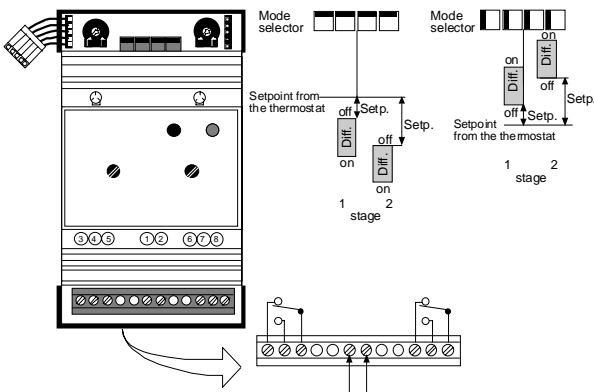

**Differential Thermostat
A27DxN1x**

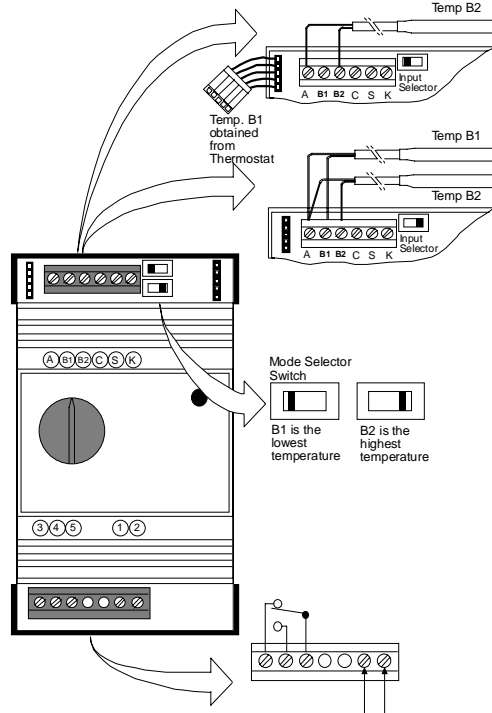

**Dual Stage Module
S27A4**

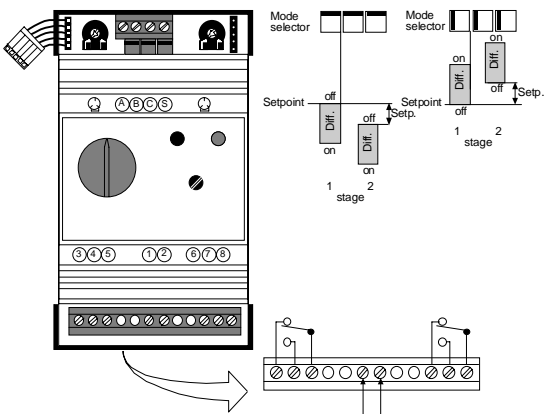

Signal Converter Module Y27L

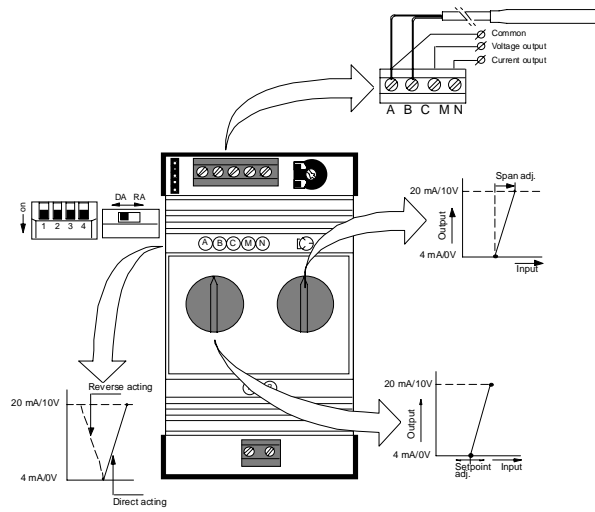

Temperature Display Module D27A

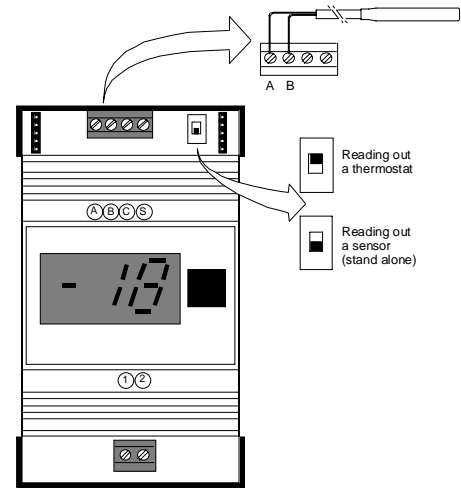

DIP switch selector		1	2	3	4
Input Signal	Thermostat	off			
	Sensor	on			
Setpoint range	-50 to 0°C		on	on	
	0 to 50°C		on	off	
	50 to 100°C		off	off	
Span range	2 to 20°C				on
	20 to 200°C				off

Applications

1- stage coldstore controller with temp. reading at four locations and free cooling.

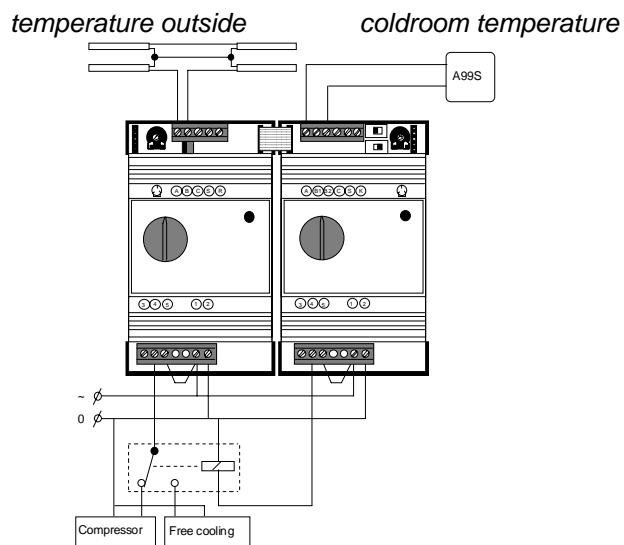

2 - stage liquid chiller with display and frostprotection

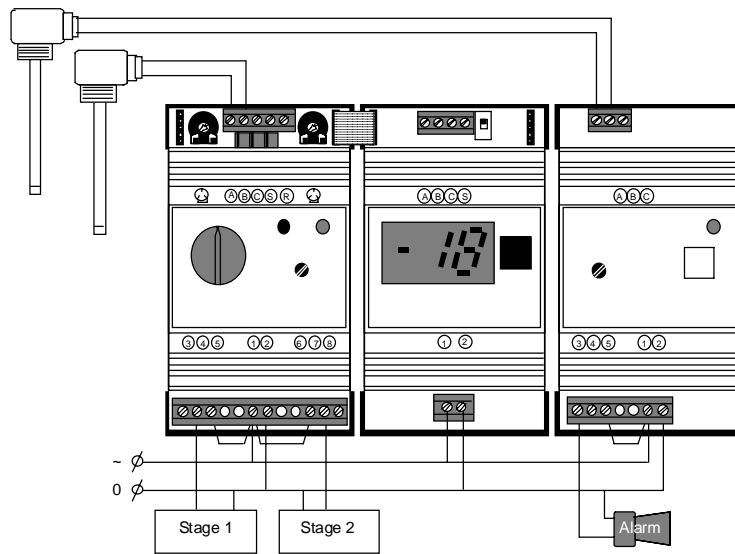

Four stage control with read-out and analogue output

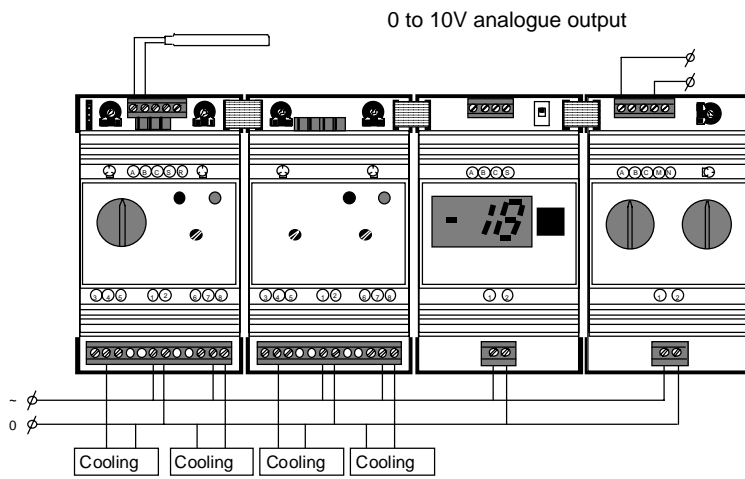

Note

Specifications

General System 27 NOVA

Output relay rating	SPDT 10(5)A 250 V ac 10 A 30 V dc
Operating ambient temperature	-10 to +50 °C
Storage temperature	-40 to +70 °C
Operating (storage) R.H.	10 to 90 % R.H. (non condensing)
Terminals	screw type max. wire thickness 2,5 mm ²
Power supply	230 V ac +10% / -15% ; 50/60 Hz 24 V ac +10% / -15% ; 50/60 Hz

Additional specification for display modules

Power supply	230 V ac +10% / -15% ; 50/60 Hz 24 V ac/dc +10% / -15% ; 50/60 Hz
Resolution	1°C
Accuracy	± 2 °C

Signal converter

Power supply	230 V ac +10% / -15% ; 50/60 Hz 24 V ac +10% / -15% ; 50/60 Hz
Output load	voltage output Rmin = 1 k Ω current output Rmax = 500 Ω

The performance specifications are nominal and conform to acceptable industry standards. For applications at conditions beyond these specifications, consult the local Johnson Controls office or representative. Johnson Controls shall not be liable for damages resulting from misapplication or misuse of its products.



Johnson Controls International, Inc.

Headquarters: Milwaukee, WI, USA
 European Headquarters: Westendhof 8, 45143 Essen, Germany
 European Factories: Lomagna (Italy), Leeuwarden (The Netherlands) and Essen (Germany)
 Branch Offices: Principal European Cities.
 This document is subject to change

Printed in Europe

Series T22SRX/T25B

One and Two Stage Room Thermostats for Heating, Cooling or Air-conditioning

Introduction

These room thermostats are designed to control heating and/or cooling equipment, in commercial industrial or residential installations. Typical uses are for unit heaters, fan coils, cooling rooms etc. Type T22SRX can be used for either heating or cooling. Type T25B (2 stages) can be used for:

- two stages heating
- two stages cooling
- heating/cooling with dead band and automatic change over

Description

These thermostats with a sturdy steel cover are provided with a liquid filled sensing element. This element is formed to achieve maximum sensitivity to surrounding air temperature changes. Coupled with a highly efficient diaphragm and leverage mechanism, the element operates a totally enclosed Penn switch contact with a close differential switching action without the use of "heat or cool" anticipators.



T22SRX (right) and T25B (left) room thermostats.

Note

These controls are designed for use only as operating controls. Where an operating control failure would result in personal injury or loss of property it is the responsibility of the installer to add devices or systems that protect against, or warn of, control failure.

Optional constructions

(quantity orders only):

- Custom labelling.
- Heat-Off-Cool selector switch (T22 only).
- Bimetal thermometer (T22SRX-9100 is executed with a built-in thermometer).
- Signal lamp in cover (T25B-9103 is executed with a signal lamp).

Feature and Benefits

<input type="checkbox"/> Liquid filled elements.	Accurate control and quick response.
<input type="checkbox"/> Dust tight Penn switch.	Prevent pollution of the contacts by electrostatic influences.
<input type="checkbox"/> Small differential.	No heat anticipators required
<input type="checkbox"/> Two Stage Thermostats with dead band and automatic change-over.	Suitable for heating/cooling.

Mounting

The devices are suitable for wall mounting. After removing the cover, the mounting holes will become visible.

Adjustment

T22SRX and T25B models are available with knob adjustment or with a concealed scale, screwdriver adjustment. For details see selection table. T22SRX models have a fixed differential of 1 K. T25B models have an adjustable differential between stages of 1 to 3 K.

Contact functions

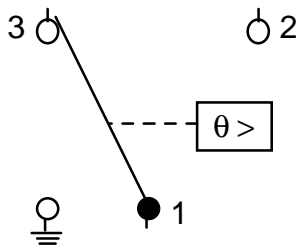

Fig. 1
T22SRX

1 - 2 closes on temperature increase.

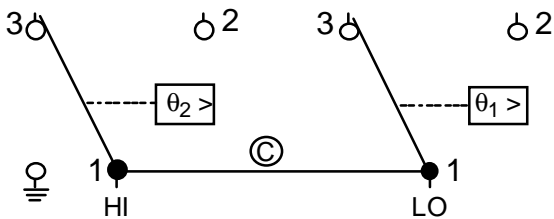
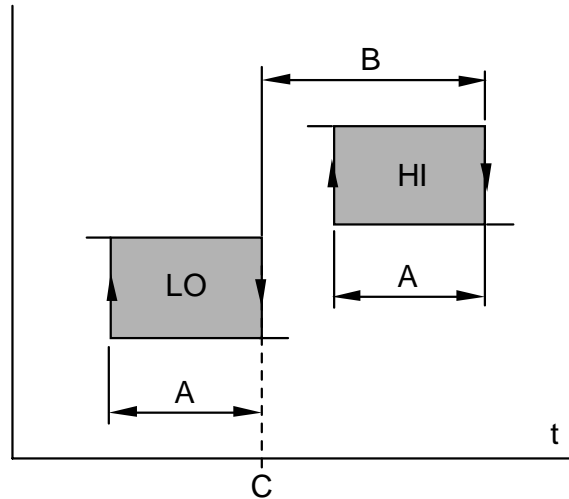

Fig. 2
T25B

1 - 2 closes on temperature increase.
(C) Removable jumper.

Switching diagram T25

(Heating Mode)



- (A) = Differential per stage (1 K).
- (B) = Differential between stages (adjustable 1 to 3 K).
- (C) = Dial setting.
- (T) = Temperature increase.
- LO = Low stage
- HI = High stage

Fig. 3

Optional construction note

If what you need is not in the specific type numbering selection table, then please contact your representative.

Repair and replacement

Repair is not possible. In case of an improperly functioning control, please check with your nearest supplier. When contacting the supplier for a replacement you should state the type/model number of the control. This number can be found on the data plate or cover label.

Type number selection table

Order number	Range in °C	Diff. per stage in K	Dif. between stages in K	Adjustment	Remarks
T22SRX-9100	5 to 32	1	-	Knob	with thermometer
T22SRX-9101	5 to 32	1	-	Knob	
T22SRX-9104	5 to 32	1	-	Concealed	
T25B-9101	5 to 32	1	1/3	Knob	
T25B-9102	5 to 32	1	1/3	Concealed	
T25B-9103	5 to 32	1	1/3	Knob	with ~230 V signal lamp (to be wired separately)

Dimensions (mm)

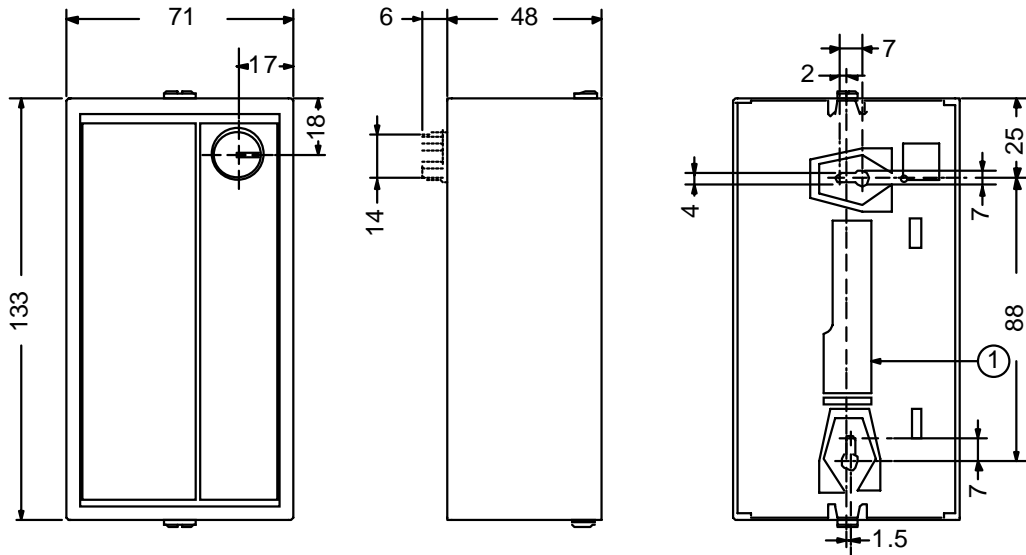

Fig. 4
T22SRX (1) Cable inlet hole

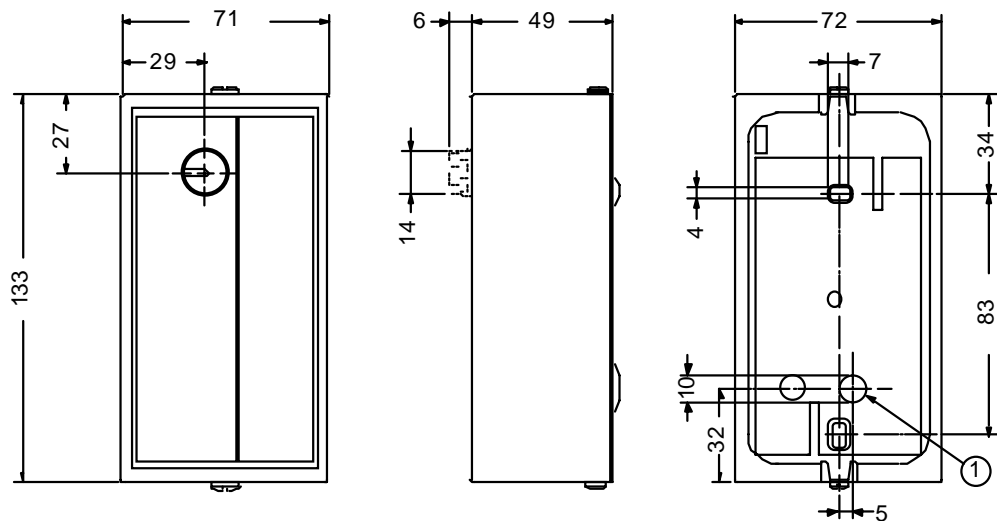

Fig. 5
T25B (1) Cable inlet hole

Specifications

Product type	T22SRX	T25B
Operating range	5 to 32°C	5 to 32°C
Number of stages	1	2
Differential per stage	1 K	1 K
between stages	-	1-3 K adjustable
Adjustment	see selection table	
Electrical rating	~15(3)A, 230V	~15(3)A, 230V
Contact function	SPDT	SPDT
CE Conformity	According to low voltage directive and EMC directive	
Ambient temp. limits	-35 to +55°C	-35 to +55°C
Material	Steel plated case and cover.	
Cover	"tawny silver" finish.	
Faceplates	dark/light brown coloured.	
Enclosure (prot. class)	IP20	IP20
Shipping weight ind. pack	0.465 kg	0.570 kg
overpack (24 pcs.)	11.5 kg	14 kg

The performance specifications are nominal and conform to acceptable industry standards. For applications at conditions beyond these specifications, consult the local Johnson Controls office or representative. Johnson Controls shall not be liable for damages resulting from misapplication or misuse of its products.

**JOHNSON
CONTROLS**

Johnson Controls International, Inc.

Headquarters: Milwaukee, WI, USA
 European Headquarters: Westendhof 8, 45143 Essen, Germany
 European Factories: Lomagna (Italy), Leeuwarden (The Netherlands) and Essen (Germany)
 Branch Offices: Principal European Cities.

This document is subject to change

Printed in Europe

T2000 Series

Low Voltage Fan Coil Thermostat



**T2000xCF-0C0 and T2000xCC-0C0
Low Voltage Fan Coil Thermostats**

Description

Use the T2000 thermostats for low voltage, Class 2 applications only to control heating, cooling, or year-round air conditioning units in commercial, industrial, or residential installations. Mount the thermostat to a 2 x 4 in. (51 x 102 mm) standard U.S. wallbox (mounting screws are not included). Integral heavy-duty slide switches provide HIGH-MED-LOW fan speed selection and ON-OFF or HEAT-OFF-COOL system switching. Typical uses include fan coil units, electric heaters, and other air conditioning and handling equipment.

Specifications

T2000 Series Low Voltage Fan Coil Thermostat	
Power Requirements	24 VAC at 50/60 Hz, Class 2
Power Consumption	less than 1/4 W (total)
Thermostat Switch	Setpoint Range: 50 to 85°F; (10 to 30°C)
System Switch	ACx Models Double-Pole, Triple Throw (DP3T) ECx Models Double-Pole, Double Throw (DPDT)
Fan Switch	All Models DP3T
Low Voltage Control Ratings	Current: 2 A Power: 48 VA
Ambient Conditions	Operating 44 to 85°F; (7 to 30°C) 85% noncondensing RH Storage -40 to 122°F; (-40 to 50°C) 85% noncondensing RH
Dimensions	3.46 x 5.24 x 1.91 in. (88 x 133 x 49 mm)

These thermostats feature an attractive neutral white plastic housing color with an adjustable setpoint knob and either a Fahrenheit or a Celsius scale. The sensing element is a gas filled bellows.

Features

- attractively-styled plastic base and removable cover that reveals a hinged Printed Circuit Board (PCB) for easy terminal connection
- system "OFF" position breaks all circuits with one switch
- no leveling and vibration problems — eliminates mounting limitations
- low voltage operation provides economical service
- gas-filled sensing element provides repeatability

Repair Parts

The T2000 thermostats are not field repairable. To order a replacement, refer to the selection chart.

To Order

To order a replacement T2000 Series thermostat, contact the nearest Johnson Controls representative. Specify the code number from the figure and table below. (Purchase separately two No. 6-32 mounting screws for the standard U.S. wallbox.)

Selection Chart

Code Number	Description
T2000ACC-0C0	Heat-Off-Cool and Fan Control Switch 24 VAC, 50 to 60 Hz, with Celsius Temperature Setpoint Scale
T2000ACF-0C0	Heat-Off-Cool and Fan Control Switch 24 VAC, 50 to 60 Hz, with Fahrenheit Temperature Setpoint Scale
T2000ECC-0C0	On-Off and Fan Control Switch 24 VAC, 50 to 60 Hz, with Celsius Temperature Setpoint Scale
T2000ECF-0C0	On-Off and Fan Control Switch 24 VAC, 50 to 60 Hz, with Fahrenheit Temperature Setpoint Scale

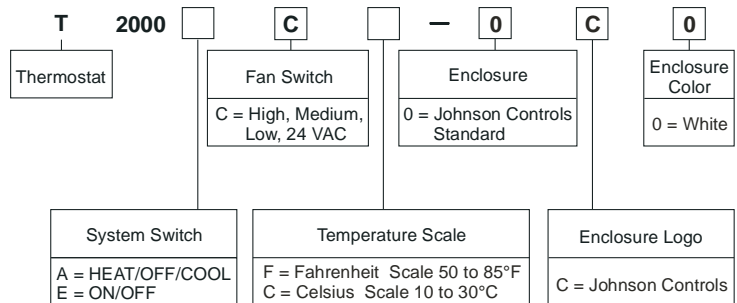

Note: All models have a temperature control knob and both system and fan switches.

Example: To order an ON/OFF thermostat with a Fahrenheit temperature scale, specify Product Code Number T2000ECF-0C0.

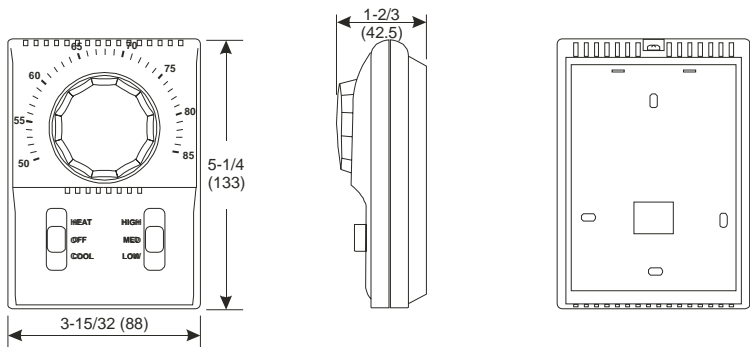

T2000xCF-0C0 Dimensions, in. (mm)

Series Bulb Well and Accessories (for remote bulb thermostats and water valves)

Introuction

Bulb wells are designed for immersion applications in fluids for cooling, heating and industrial purposes. Bulb wells are used to accommodate temperature sensing elements in cases where a direct contact with fluid is not allowed. Bulb wells are also to avoid unnecessary drainage of the system when removing the sensing element. Various models, covering a broad range of sensing elements are available. A closed tank connector and duct flange are available to cover special applications.



WEL003N601



WEL14A602R

Feature and Benefits

- | | |
|---|---|
| <input type="checkbox"/> High temperature allowable. | For high medium temperature applications |
| <input type="checkbox"/> High maximum pressure | For high pressure applications |
| <input type="checkbox"/> (monel type) | |
| <input type="checkbox"/> Various models | Covers a broad range of sensing elements including electronic sensors |

T Typenumber selection table

Item Number	See fig.	Dimensions (mm)			Material		Finishing	Max. °C	Max. Press (bar)	Remarks	Applications
		A	B	C Inside	Conn.	Tube					
WEL003N601	3	125	201	9.8	Brass	Copper		90	20	Enclosure IP54 Plastic	A99B A99B
WEL003N602R	1	125	171	9.8	Stainless Steel	Stainless Steel		370	70		A19/A28/A36 A99B
WEL11A601R	2	60	118	7.3	Brass	Copper		120	20	Style 1a	A19/A28
WEL14A600R	1	120	166	11.2	Monel	Monel		370	69		A19/A28/A36
WEL14A602R	1	125	171	9.8	Brass	Copper		120	20		A19/A28/A36 A99B
WEL14A603R	1	147	193	9.8	Brass	Copper		120	20		A19/A28/A36
WEL16A601R	2	71	117	9.5	Brass	Copper		120	20	Style 1a	A19/A28/A36
WEL17A-600	4	265	284	19.4	Steel	Copper	Tin	120	17		V47/V49
WEL17A-601	4	214	240	19.4	Steel	Copper	Tin	120	17		V47/V49
WEL17A-603	4	255	275	19.1	Monel	Monel		70	69		V47/V49
WEL18A-601	4	89	108	19.6	Monel	Monel		370	69		V47/V49
WEL18A-602	4	89	114	19.6	Steel	Brass	Tin	120	10		V47/V49

B Bulb well models

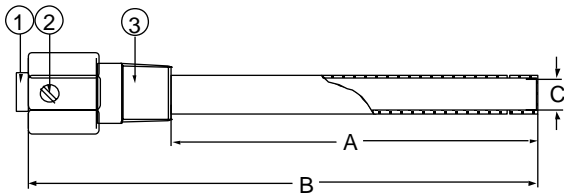

Fig 1

1. Bushing
2. Set screw
3. Adapter, 1/2"-14 NPT

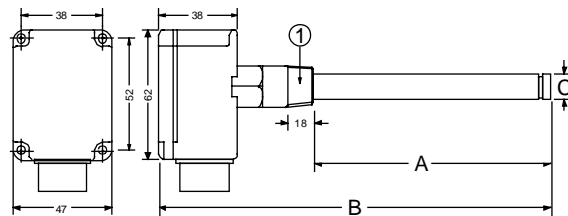

Fig. 3

1 = 1/2 - 14 NPT

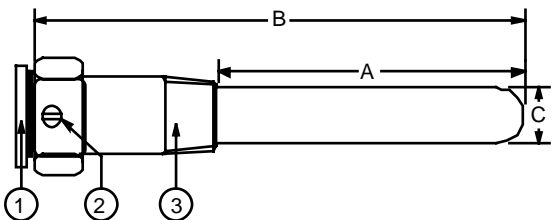

Fig. 2

1. Cable/capillary bushing
2. Clamp screw
3. 1/2-14NPT male

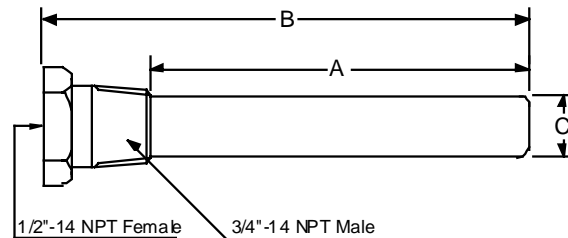

Fig. 4

Special applications

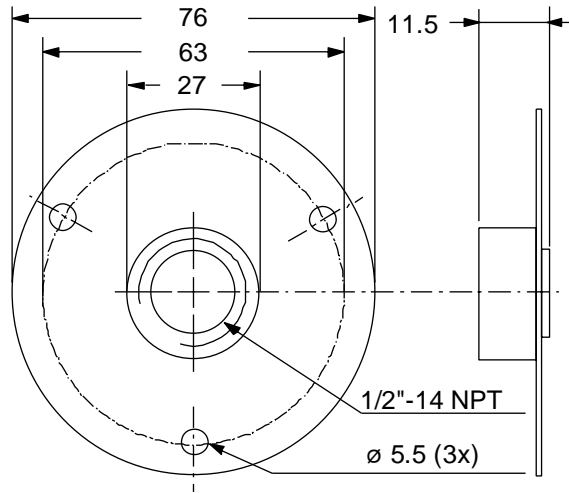

Fig. 5
Duct flange to be used with closed-tank connector FTG13A600R.
Order number **T752-1001**

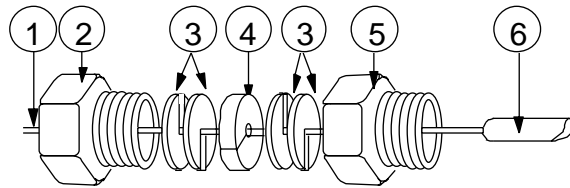

Fig. 6
Closed-tank connector
Order number **FTG13A600R**

1. Style 1b bulb support tube
2. Packing nut
3. Washer
4. Packing
5. Adapter, 1/2"-14 NPT
6. Bulb

The performance specifications are nominal and conform to acceptable industry standards. For applications at conditions beyond these specifications, consult the local Johnson Controls office or representative. Johnson Controls shall not be liable for damages resulting from misapplication or misuse of its products.



Johnson Controls International, Inc.

Headquarters: Milwaukee, WI, USA
European Headquarters: Westendhof 8, 45143 Essen, Germany
European Factories: Lomagna (Italy), Leeuwarden (The Netherlands) and Essen (Germany)
Branch Offices: Principal European Cities.

This document is subject to change

Printed in Europe

System 27 NOVA Modular Electronic Humidity Control System

Introduction

System 27 NOVA is a family of modular electronic modules designed for a wide variety of control configurations in refrigeration, heating, ventilation, air-conditioning and other related fields.

The humidity control modules can be used as a stand alone device or in conjunction with other modules such as display modules, signal converter modules etc. to achieve a wide variety of single or multiple stage applications.

Typical applications are:

- computer rooms;
- clean rooms;
- fruit storage/ripening;
- food processing;
- industrial processes.

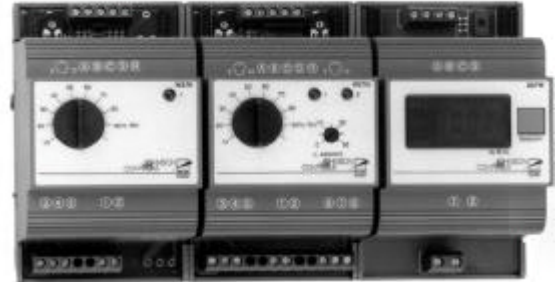

**System 27 NOVA Modular
 Humidity Controls**

Description

The modular concept was specially designed to make control configuration easier and still offer the flexibility necessary to answer the many individual control requirements encountered today.

Feature and Benefits	
q Modular design	Provides the flexibility to realise the required control set up without redundancy and makes future expansion easy.
q “Plug-in” quick connector wiring system	Eliminates wiring between modules and reduces installation cost.
q Adjustable differential and humidification/dehumidification setting	Provides flexibility to match any combination of heating or cooling applications.
q Interchangeable humidity transmitters with different housings	Matches various applications.
q Attractive DIN-rail mount housing	Easy and quick to install.
q Setpoint shift output function	Modules can be used for “multiple setpoint” applications.

The System 27 NOVA family includes the following modules:

W27 Humidity Control Modules



These one- or two-stage humidity control modules can be used as a low cost control for stand alone applications or, when connected in parallel, for multistage applications. The control output(s) is a single-pole, double-throw (SPDT) relay with LED indication. It features humidification and dehumidification modes of operation and an adjustable differential.

D27W Humidity Display Modules



A display connected to a humidity control module gives a digital indication of the measured humidity or setpoint. It is also possible to connect a sensor directly to the D27W (the sensor is powered by the D27W).

The display can be connected to a humidity control module very easy by using the quick connector system.

Y27M Signal Converter



This module converts a voltage input signal to a standardised output signal of 0 to 10 Vdc or 4 to 20 mA. The input signal can either be obtained from a humidity sensor or a humidity control module. The signal converter can be used for those applications where an analogue output is required. Such as; to a motor, motor actuated valve, recorder etc.

HT-9000 Humidity Sensor



Sensors are available for room, duct or build-in applications. Please refer to the HT-9000 humidity sensor bulletin.

Note

The System 27 modules are intended to control equipment under normal operating conditions. Where failure or malfunction of the modules could lead to an abnormal operating condition that could cause personal injury or damage to the equipment or other property, other devices (limit or safety controls) or systems (alarm or supervisory systems) intended to warn of or protect against failure or malfunction of the modules must be incorporated into and maintained as part of the control system.

Application examples

At page 6 you will find some applications examples. For more detailed information about wiring and adjustment reference should be made to the installation sheets.

Repair and Replacement

Repair is not possible. In case of an improperly functioning control, please check with your nearest supplier.

When contacting the supplier for a replacement you should state the type-model number of the control. This number can be found on the dataplate.

Accessories dim. in mm

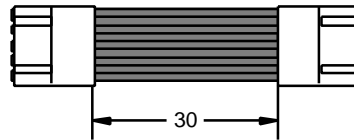

Fig. 1
WRE027N600
Quick Connector for connecting System 27 NOVA modules.

Dimensions (mm)

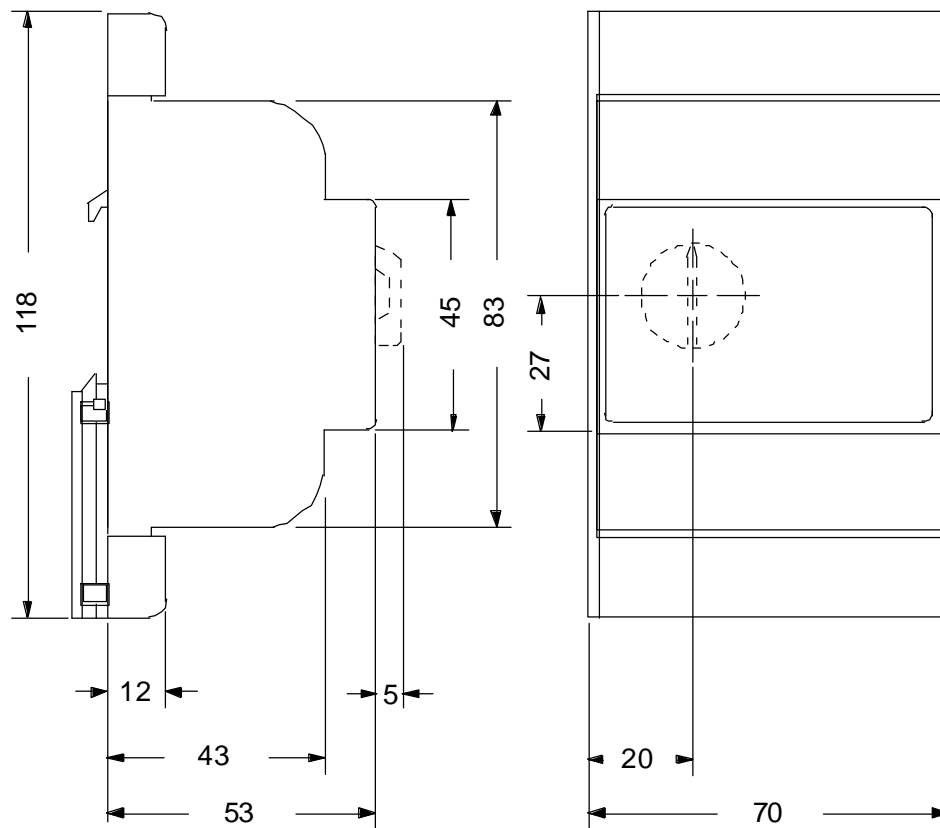

Fig. 2
System 27 NOVA Modules

Type Number Selection Table

W27 Humidity Control Modules

One Stage Humidistat

Order number	Power supply	Setpoint range	Additional
W27N11	24 V ac/dc	10 to 100% R.H.	* Mode: field adjustable * Differential: 2 to 10% R.H. * SPDT contact 10(5)A 250 V ac * Setpoint shift: 0 to 20% R.H.
W27N21	230 V ac		

Two Stage Humidistat

Order number	Power supply	Setpoint range	Additional features
W27N12	24 V ac/dc	10 to 100% R.H.	* Mode: field adjustable * Differential: 2 to 10% R.H. * 2x SPDT contact 10(5)A 250V ac * Setpoint shift: 0 to 20% R.H.
W27N22	230 V ac		

Humidity Display Modules

Order number	Power supply	Additional features
D27W1N4	24 V ac	* Can be used as stand alone or in conjunction with a humidity control module * Display range: 0 to 100% R.H
D27W2N4	230 V ac	

Y27M Signal Converter

Order number	Power supply	Setpoint range (V)	Span range (V)
Y27M1	24 V ac	0 to 10	0 to 10
Y27M2	230 V ac	0 to 10	0 to 10

Wiring & Adjustments

One-stage Humidistat W27Nx1

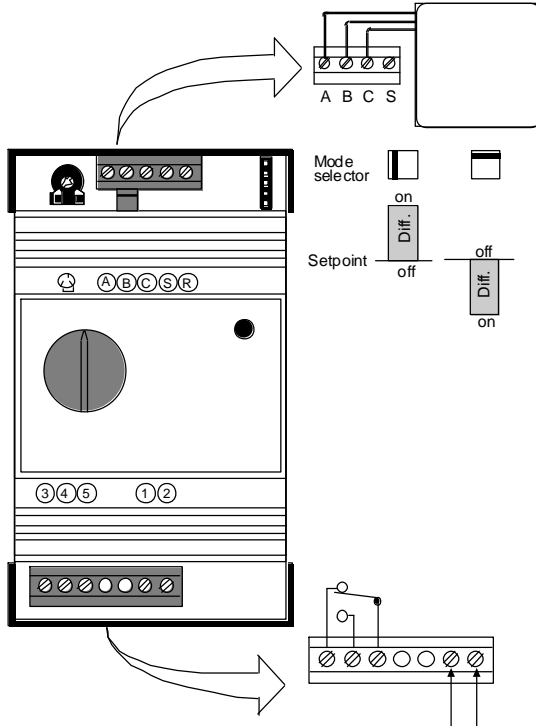

Two-stage Humidistat W27Nx2

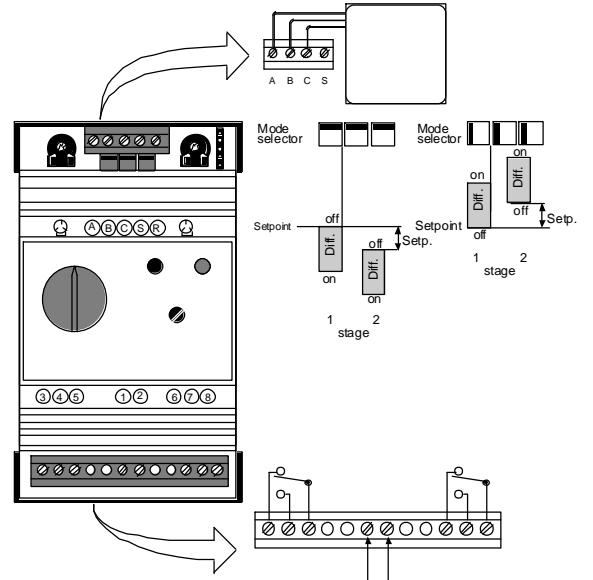

Humidity/Display module D27WxN4

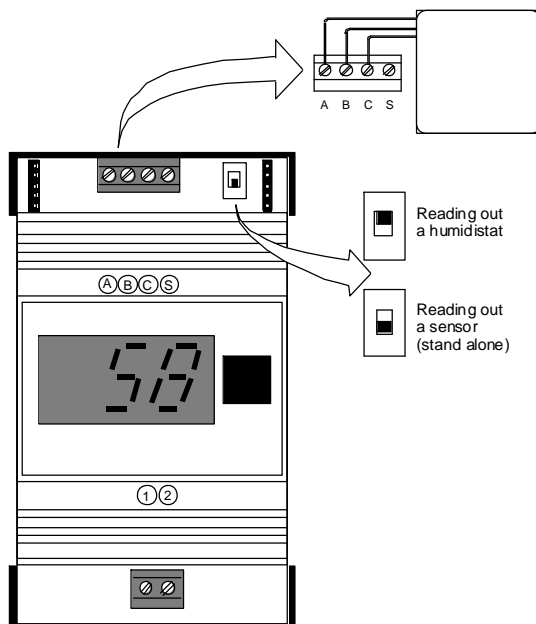

Signal Converter Module Y27Mx

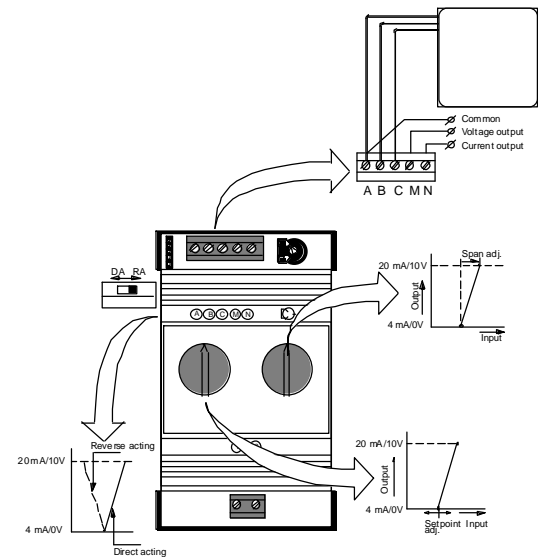

Applications

Two stage humidity control with read-out

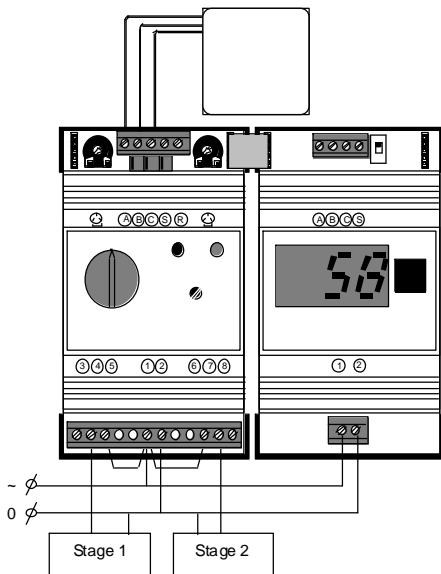

Three stage humidity control

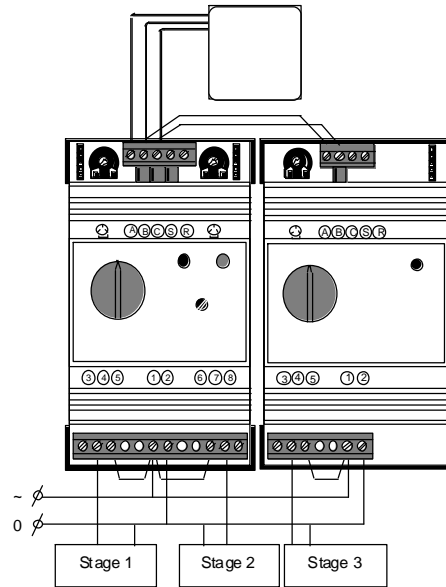

One stage humidity control with read-out and analogue out-put

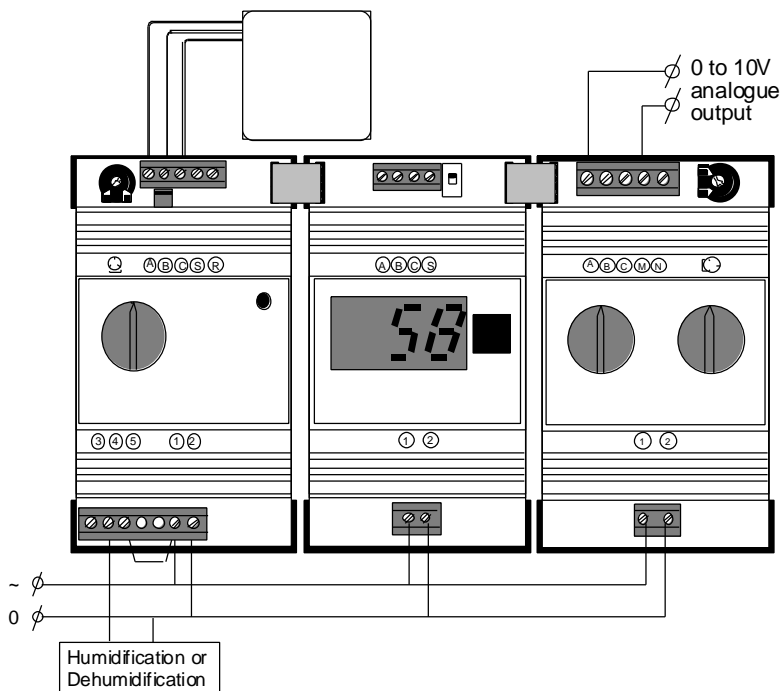

Notes

Specifications

General System 27 NOVA

Output relay rating	SPDT 10(5)A 250 V ac 10 A 30 V dc
Operating ambient temperature	-10 to +50 °C
Storage temperature	-40 to +70 °C
Operating (storage) R.H.	10 to 90 % R.H. (non condensing)
Terminals	screw type max. wire thickness 2,5 mm ²
Power supply	230 V ac +10% / -15% ; 50/60 Hz 24 V ac/dc +10% / -15% ; 50/60 Hz

Additional specification for display modules

Power supply	230 V ac +10% / -15% ; 50/60 Hz 24 V ac +10% / -15% ; 50/60 Hz
Resolution	1% R.H.
Accuracy	± 2% R.H.

Signal converter

Power supply	230 V ac +10% / -15% ; 50/60 Hz 24 V ac +10% / -15% ; 50/60 Hz
Output load	voltage output Rmin = 1 k Ω current output Rmax = 500 Ω

The performance specifications are nominal and conform to acceptable industry standards. For applications at conditions beyond these specifications, consult the local Johnson Controls office or representative. Johnson Controls shall not be liable for damages resulting from misapplication or misuse of its products.



Johnson Controls International, Inc.

Headquarters: Milwaukee, WI, USA
 European Headquarters: Westendhof 8, 45143 Essen, Germany
 European Factories: Lomagna (Italy), Leeuwarden (The Netherlands) and Essen (Germany)
 Branch Offices: Principal European Cities.

This document is subject to change

Printed in Europe

Series W43 Room Humidistats

Introduction

These room humidistats are designed to control humidification or dehumidification equipment. It provides SPDT control.

Description

The sensing element consists of carefully selected and processed human hair, proven to be the most sensitive and stable material known for this application. Under normal conditions these controls retain their sensitivity and accuracy for many years.

Note

These controls are designed for use only as operating controls. Where an operating control failure would result in personal injury or loss of property it is the responsibility of the installer to add devices or systems that protect against, or warn of, control failure.



W43C
Room Humidistat

Feature and Benefits

<input type="checkbox"/> Wide range 0 to 90% R.H.	Can be used for most of the applications.
<input type="checkbox"/> Dust tight Penn switch.	Prevents pollution of the contacts by electrostatic influences.
<input type="checkbox"/> SPDT Contacts.	Control can be used for either humidification or dehumidification.
<input type="checkbox"/> Use of human hair.	Proven to be the most sensitive and stable material.
<input type="checkbox"/> Field adjustable high and low limit stops.	Can be set within small ranges. Can be used as dial lock.
<input type="checkbox"/> Separate mounting plate.	Makes mounting very easy.

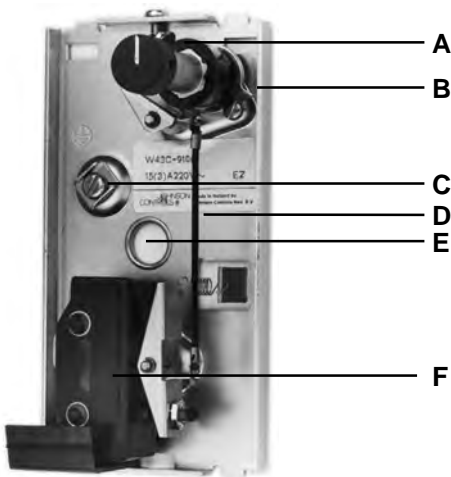

Fig. 1
W43C Room Humidistat, cover removed

- A. High limit stop
- B. Low limit stop
- C. Earthing screw
- D. Hair element
- E. Cable inlet
- F. Contact block

Contact functions

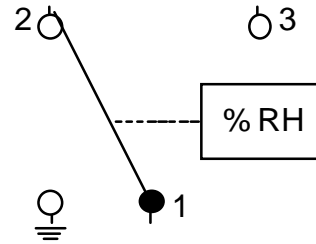

Fig. 2
Contacts 1-3
close on increase in relative humidity .

Contacts 1-2
close on decrease in relative humidity.

Repair and Replacement

Repair is not possible. In case of an improperly functioning control, please check with your nearest supplier. When contacting the supplier for a replacement you should state the type/model number of the control. This number can be found on the data plate or cover label.

Type number selection table

Description	Type number
External knob adjustment	W43C-9100

Dimensions (mm)

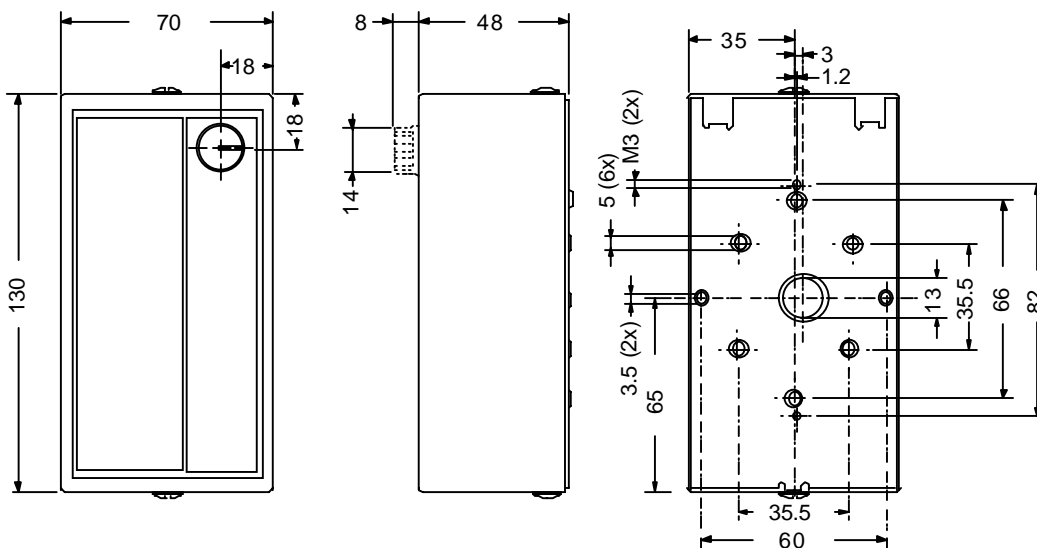

Fig. 3

Note

Specifications

Product type	W43C	
Operating range	0 to 90% R.H.	
Differential	≈ 4% R.H. (fixed)	
Adjustment	External (knob)	
Off Positions	'Deh off'	For dehumidification off turn dial knob to full counter-clockwise position
	'Hum off'	For humidification off turn dial knob to full clockwise position
Limit stops	Field adjustable, high and low limit stops	
Dial Lock	High and low limit stops can be set to prevent dial from being rotated	
Mounting	Flush mounting (separable mounting plate)	
Contact function	SPDT contacts in dust-tight enclosure	
Material	Cover	Sheet metal, tawny silver finish, face plate in two shades of brown
	Sensing element	Specially treated human hair (210 strands)
Enclosure	IP20	
Ambient temperature limits	0 to +40°C	
Electrical ratings	~15(3)A 230V	
Shipping weights	Ind. pack	0.46 kg
	Overpack	11.5 kg (24 pcs.)

The performance specifications are nominal and conform to acceptable industry standards. For applications at conditions beyond these specifications, consult the local Johnson Controls office or representative. Johnson Controls shall not be liable for damages resulting from misapplication or misuse of its products.



Johnson Controls International, Inc.

Headquarters: Milwaukee, WI, USA
 European Headquarters: Westendhof 8, 45143 Essen, Germany
 European Factories: Lomagna (Italy), Leeuwarden (The Netherlands) and Essen (Germany)
 Branch Offices: Principal European Cities.

This document is subject to change

Printed in Europe

Series F61 Liquid Flow Switches

Introduction

The F61 liquid flow switches can be used in liquid lines carrying water, sea water, swimming pool water, ethylene glycol or other liquids not harmful to the specified materials. The switches have SPDT contacts and can be wired to energise one device and de-energise another device powered from the same source when liquid flow either exceeds or drops below the set flow rate. There are two different models available. The pipe insert models and the T-body types for low-flow applications. All materials in contact with the liquid are specified in the part "specifications". At doubt about the liquid used with regards to these materials it is advised to contact the liquid supplier. The IP43 versions can be used for liquid temperatures above dewpoint while the vapour proof IP67 versions can be used for liquid temperatures of minus 30°C and up or in high moisture environments. Typical applications are to shut down the compressor on liquid chiller systems, to prove flow on electric immersion heaters and to give a signal or alarm when the pump on condenser cooling system shuts down.



F61 Liquid Flow Switches

Feature and Benefits

<input type="checkbox"/> T-body and Pipe-insert types available	For low flow applications (0.04 dm ³ /s) up to flows of 48 dm ³ /s
<input type="checkbox"/> Polycarbonate IP43 enclosure	For indoor and outdoor applications.
<input type="checkbox"/> Vapour tight IP 67 enclosure	For low temperature applications.
<input type="checkbox"/> Stainless steel Pipe-insert type	Used for liquids like swimming pool water
<input type="checkbox"/> Large wiring space	Makes wiring convenient and easily accessible
<input type="checkbox"/> Range screw easy accessible	Easy to adjust in the field

Note

These controls are designed for use only as operating controls. Where an operating control failure would result in personal injury or loss of property, it is the responsibility of the installer to add devices or systems that protect against, or warn of, control failure.

Caution

Do not use with hazardous fluids or in hazardous atmosphere

Installation

Pipe-insert types

To allow the switch to detect changes in the liquid flow, the paddle must not touch the pipe or any other obstacle in the pipe. The Pipe-insert types are mounted on top of the liquid line. An angle of 120° is allowed as indicated in Fig. 1. To keep the flow switch close to the pipe and to provide an adequate paddle length in the flow stream the use of a reducing tee for larger pipe sizes is advised. The arrow on the cover must point in the flow direction. To avoid turbulence it is advised to mount the controller at a distance of minimal 10xD (on each side) away from elbows, valves and other appendages. The Pipe-insert types can be mounted in a vertical pipe as long as the flow is up-stream. This mounting position affects the adjustment of the controller.

The 6" paddle can be trimmed as indicated on page 6. For added stiffness it is advised to mount the smaller paddles behind the largest one.

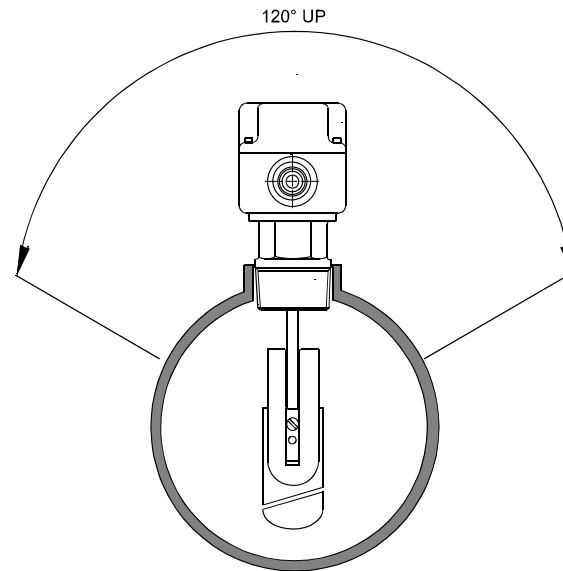

Fig1

T-body types

These types are mounted in the liquid line with the housing at the top. An angle of 120° is allowed as indicated in Fig. 1. The arrow on the body and cover must point in the flow direction. To avoid turbulences it is advised to mount the controller at a distance of minimal 10xD (on each side) away from elbows, valves and other appendages. The T-body types cannot be mounted in a vertical pipe.

Wiring

A special vapour proof PG-16 nipple for cable inlet is delivered by the IP67 type controls. This nipple has to be used to keep the control vapour tight.

Contact function

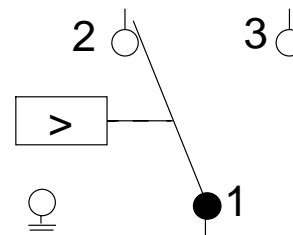

Fig. 2

1-3 closes on flow increase.

Adjustment

The switches are factory set at minimal flow setting. On the application the setting can be adjusted by the range screw under the cover as indicated in fig. 3. For higher flow rates turn the adjusting screw clockwise.

Note

Prevent to adjust the setting below factory setting as this may result in the switch failing to return to "no flow" position.

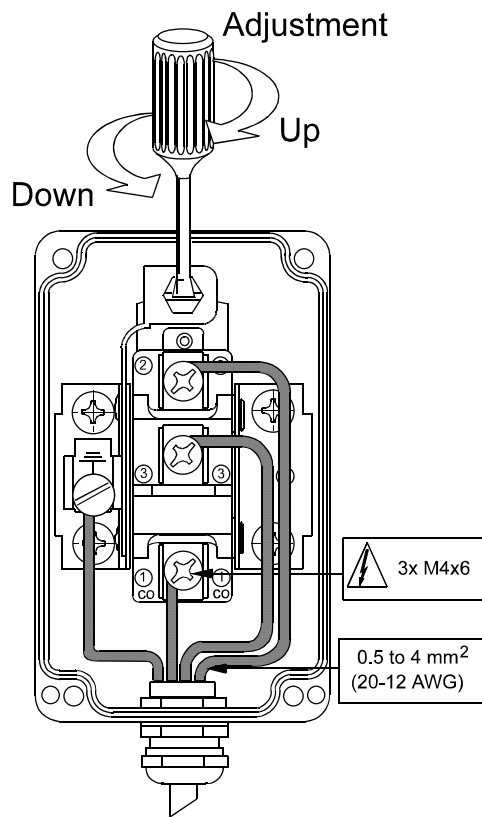

Fig. 3

Flow rates

Note : Please note that these curves are approximate data obtained in a laboratory test by use of water and are not necessarily representative or accurate when compared with various field applications. Values are affected by the liquid used and the mounting position of the controller. Flow rates for pipe sizes 3" and up are calculated values.

Flow rates T-body Types

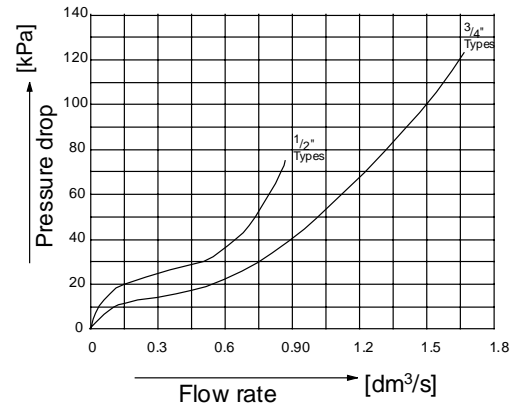

Fig. 4

Pressure drop Pipe Insert Types

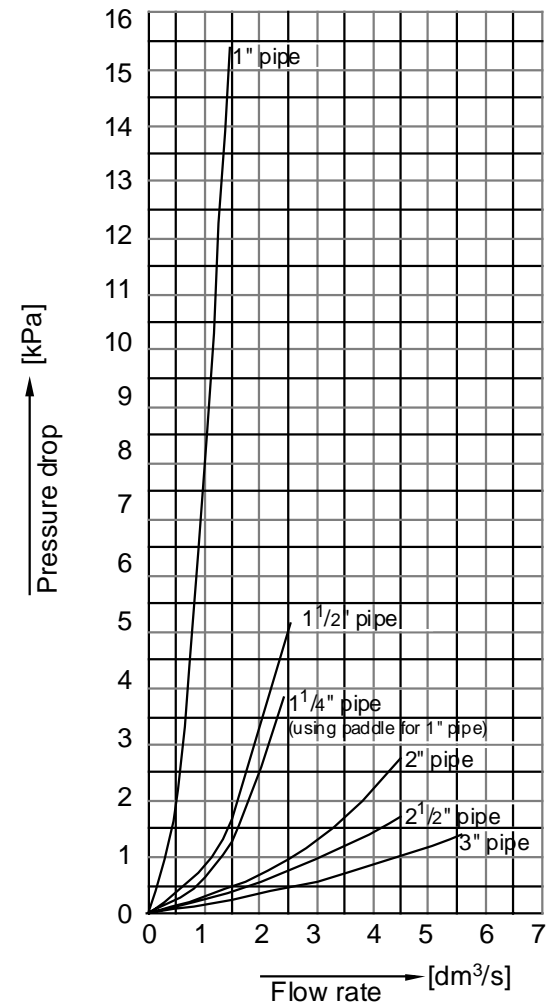

Fig. 5

Flow rate table Pipe Insert Types

		Paddle size		Line pipe size									
				1"	1 1/4"	1 1/2"	2"	2 1/2"	3" *	4" *	5 *	6" *	8" *
Minimum adjustment	Flow increase	1"-2"-3"	dm ³ /s	0.3	0.4	0.5	0.9	1.1	1.7	4.2	7.8	12	24
			(m ³ /h)	(1.0)	(1.3)	(1.7)	(3.1)	(4.1)	(6.2)	(15)	(28)	(43)	(85)
	1-3 closes	6"	dm ³ /s	-	-	-	-	-	-	2.4 #	3.6 #	4.8	13
			(m ³ /h)	-	-	-	-	-	-	(8.5) #	(13) #	(17)	(47)
	Flow decrease	1"-2"-3"	dm ³ /s	0.15	0.2	0.3	0.6	0.8	1.2	3	6.4	10	20
			(m ³ /h)	(0.6)	(0.8)	(1.1)	(2.2)	(2.8)	(4.3)	(11)	(23)	(36)	(73)
1-2 closes	6"	dm ³ /s	-	-	-	-	-	-	1.7 #	2.5 #	3.4	11	
		(m ³ /h)	-	-	-	-	-	-	(6) #	(9) #	(12)	(39)	
Maximum adjustment	Flow increase	1"-2"-3"	dm ³ /s	0.6	0.9	1.2	1.8	2.2	3.4	8.1	16	24	48
			(m ³ /h)	(2.0)	(3.0)	(4.4)	(6.6)	(7.8)	(12)	(29)	(56)	(85)	(173)
	1-3 closes	6"	dm ³ /s	-	-	-	-	-	-	5.0 #	7.6 #	9.2	26
			(m ³ /h)	-	-	-	-	-	-	(18) #	(27) #	(33)	(94)
	Flow decrease	1"-2"-3"	dm ³ /s	0.5	0.8	1.1	1.7	2.0	3.2	7.8	1"5	23	43
			(m ³ /h)	(1.9)	(2.8)	(4.1)	(6.1)	(7.3)	(11.4)	(28)	(53)	(82)	(116)
1-2 closes	6"	dm ³ /s	-	-	-	-	-	-	4.8 #	7 #	8.7	25	
		(m ³ /h)	-	-	-	-	-	-	(17) #	(25) #	(31)	(91)	

1 dm³/s = 3.6 m³/h = 15.6 U.S. gal./min. = 13 U.K. gal./min.

* Flow rates for these sizes are calculated.

For 4" and 5" line pipe the 6" paddle is trimmed

Accessories for Pipe-insert types

- KIT21A600 : 1", 2", 3" paddle, phosphor bronze
 KIT21A601 : 6" paddle, phosphor bronze
 KIT21A602 : 1", 2", 3" and 6" paddles stainless steel AISI 301

Repair and replacement

Repair is not possible. In case of an improperly functioning control, please check with your nearest supplier. When contacting the supplier for a replacement you should state the type/model number of the control. This number can be found on the data plate or cover label.

Type number selection table

Pipe-insert	Range dm ³ /sec.	Connection	IP class	Paddles phosphor br. ASTM B103	Paddles st. st AISI 301	Paddles st. st AISI 304	Application
F61SB-9100	0.15/46	R1"DIN2999(ISO R7)	IP43	1", 2", 3"	–	–	Water/Ethylene glycol
F61SB-9103	0.15/46	R1"DIN2999(ISO R7)	IP43	1", 2", 3"	6"	–	Water/Ethylene glycol
F61TB-9100	0.15/46	1-111/2 NPT	IP67	1", 2", 3"	6"	–	Brine, sea water
F61TB-9102	0.15/46	1-111/2 NPT	IP67	–	1", 2", 3", 6"	–	Brine, sea water
F61TB-9103	0.15/46	R1"DIN2999(ISO R7)	IP67	1", 2", 3"	6"	–	Water/Ethylene glycol
F61TB-9200	0.15/46	R1"DIN2999(ISO R7)	IP67	–	–	1", 2", 3"	Sea water, swimming pool water

T-Body	Range dm ³ /sec.	Connection	IP class	Application
F61SD-9150	0.04/0.07	1/2-14 NPTF	IP43	Water/Ethylene glycol
F61SD-9151	0.08/0.11	1/2-14 NPTF	IP43	Water/Ethylene glycol
F61SD-9175	0.04/0.07	3/4-14 NPTF	IP43	Water/Ethylene glycol
F61TD-9150	0.04/0.07	1/2-14 NPTF	IP67	Water/Ethylene glycol

Note : Paddles not mounted, packed with the control.

Dimensions

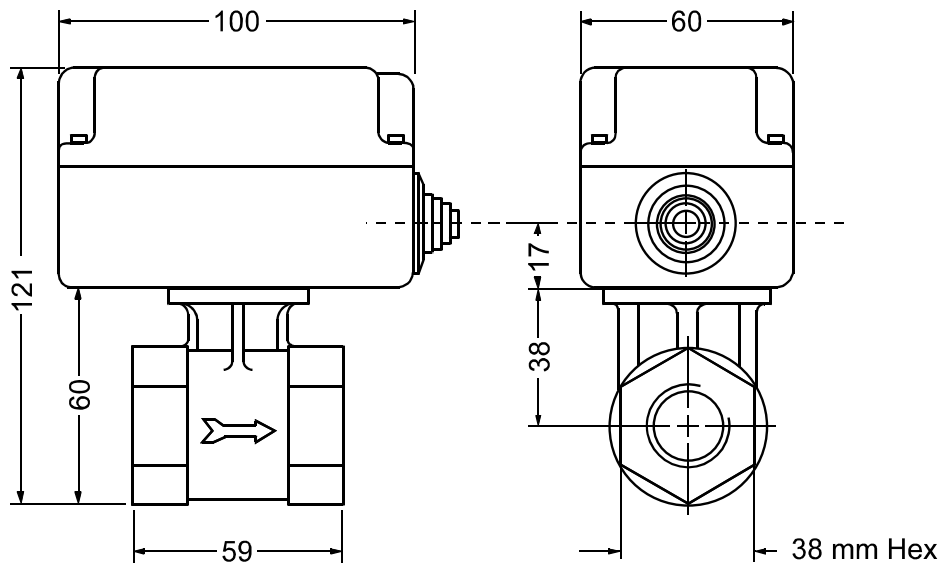

Fig. 6
F61SD/TD

- A . Cable inlet hole \varnothing 22.3 mm; Grommet installed on IP43 types.
- B . Vapour proof PG-16 nipple delivered with IP67 types

Dimensions

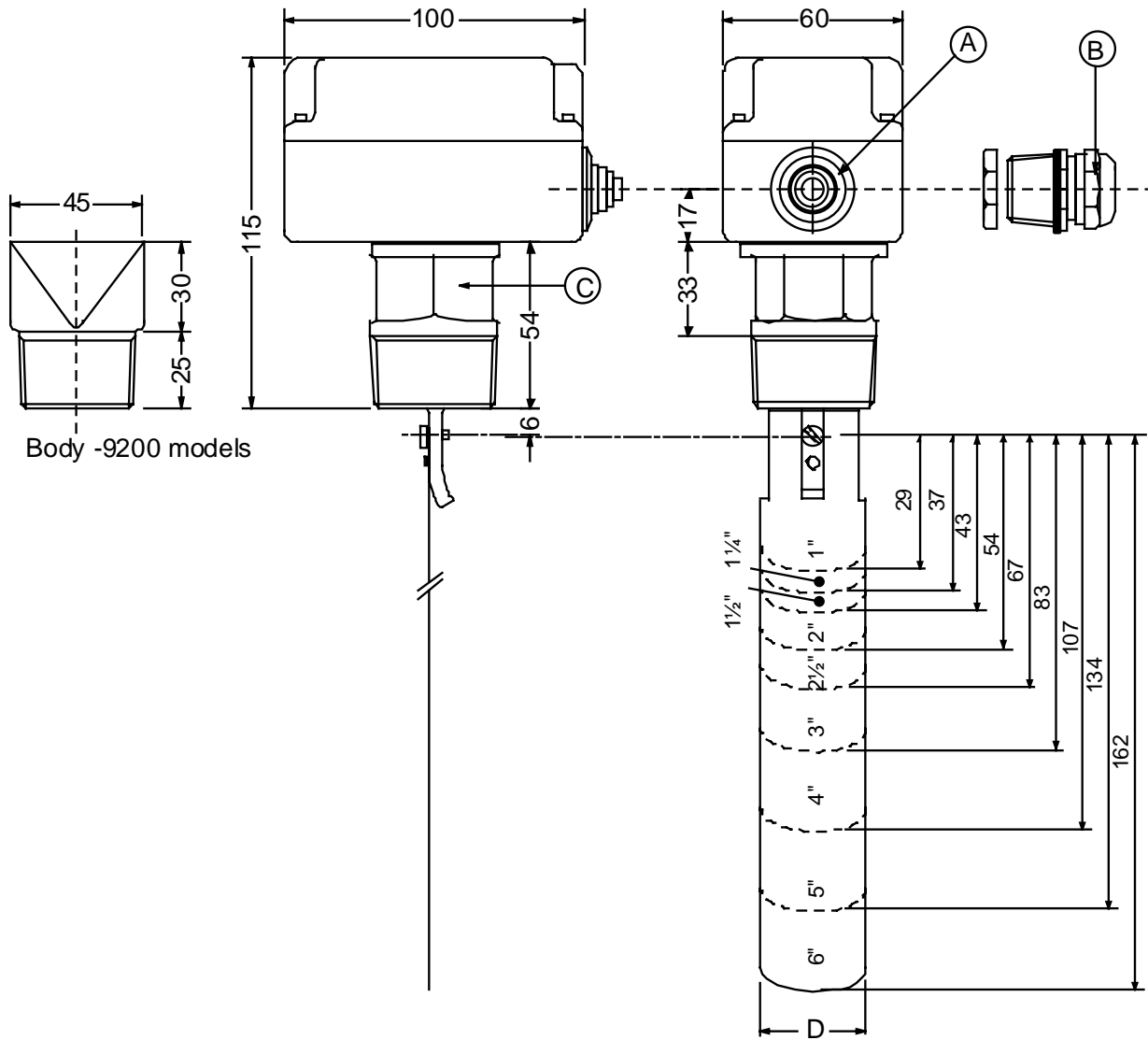

Fig. 7
F61SB/TB

- A. Cable inlet hole $\text{\O} 22.3$ mm; grommet is installed on IP43 types.
- B. Vapour proof PG-nipple delivered with IP67 types.
- C. 30 mm Hex. F61SB/TB
45 mm F61TB-9200
- D. 1" paddel D = 25mm
2", 3", 6" paddel D = 29 mm

Note

Specifications

Pipe Insert Types					T-body Types	
Type number	F61SB-9100 F61SB-9103	F61TB-9100 F61TB-9102	F61TB-9103	F61TB-9200	F61SD-91xx	F61TD-9150
Flow Rates	see selection table					
Pipe connection	see selection table					
Max liquid pressure	20 bar	10 bar	20 bar	10 bar	10 bar	10 bar
Max. liquid temp.*	120°C	100°C	120°C	100°C	100°C	100°C
Min. liquid temp.**	0°C	-30°C	-30°C	-30°C	0°C	-30°C
Max. ambient temp.*	+55°C	+55°C	+55°C	+55°C	+55°C	+55°C
Min. ambient temp.**	-40°C	-40°C	-40°C	-40°C	-40°C	-40°C
Ambient humidity	10-95%	10-95%	10-95%	10-95%	10-95%	10-95%
Contact type	SPDT snap-acting switch					
Electrical rating	15(8) A 230Vac					
Wiring connections	screw terminals 1 up to 2.5mm ²					
Enclosure	IP43	IP67 Vapour proof	IP67 Vapour proof	IP67 Vapour proof	IP43	IP67 Vapour proof
Materials cover / case	Polycarbonate					
Materials in contact with liquid	see selection table					
Paddles	see selection table					
Bellows	phosphor bronze CuSn 6	phosphor bronze CuSn 6	phosphor bronze CuSn 6	stainless steel AISI 316L DIN1.4404	phosphor bronze	phosphor bronze
Rod	brass CuZn36Pb1.5	brass CuZn36Pb1.5 nickel plated	brass CuZn36Pb1.5	stainless steel AISI 316L DIN1.4401	bronze ASTM B140 alloy 316	bronze ASTM B140 alloy 316
Body	brass CuZn40Pb2	brass ASTM B584 alloy C84400	brass CuZn40Pb2	stainless steel AISI 316 DIN1.4401	brass ASTM B584 alloy C84400	brass ASTM B584 alloy C84400
Bellows washer	brass CuZn37F38	brass CuZn37F38 nickel plated	brass CuZn37F38	-	red brass	ASTM B36 alloy 3
Body washer	brass CuZn37F38	-	brass CuZn37F38	-	phosphor bronze ASTM B103 alloy Al	phosphor bronze ASTM B103 alloy Al
Screw paddle conn.	¼ hard brass	silicon bronze	¼ hard brass	stainless steel AISI 316 DIN1.4401	¼ hard brass	¼ hard brass
Washer paddle conn.	phosphor bronze	phosphor bronze	phosphor bronze	stainless steel AISI 316 DIN1.4401	-	-
Seat	-	-	-	-	red brass ½ hard	red brass ½ hard
Silver solder	L-Ag45	-	L-Ag45	-	SN50Pb	SN50Pb
Softsolder	L-SnAg5	L-SnAg5	L-SnAg5	-	Ag 15 P	Ag 15 P
Diaphragm	Rubber EPDM	-	Rubber EPDM	-	-	-
Shipping weight individual pack	0.7 kg	0.7 kg	0.7 kg	1.0 kg	1.0 kg	1.0 kg
overbox	15 kg (24 pcs)	15 kg (24 pcs)	15 kg (24 pcs)	22 kg (24 pcs)	22 kg (24 pcs)	22 kg (24 pcs)
Vibration	acc.to DIN 89011 Kennlinie I					

* The max. liquid temperature of 100°C is at 20°C ambient. At higher ambient temperatures the max. allowed liquid temp. becomes lower. Models F61SB-9100/9103 and F61TB-9103 are tested at 21°C ambient. The max. liquid temp. is 110°C at an ambient temp. of 21°C for ambient temp. <20°C the max. liquid temp. is 120°C. The temperature of the electrical switch inside should not exceed 70°C.

** The low liquid temperature combined with a low ambient temp. should not lead to freezing of the liquid inside the body / bellows. Please observe the liquid freezing point.

The performance specifications are nominal and conform to acceptable industry standards. For applications at conditions beyond these specifications, consult the local Johnson Controls office or representative. Johnson Controls shall not be liable for damages resulting from misapplication or misuse of its products.

**JOHNSON
CONTROLS**

Johnson Controls International, Inc.

Headquarters: Milwaukee, WI, USA
 European Headquarters: Westendhof 8, 45143 Essen, Germany
 European Factories: Lomagna (Italy), Leeuwarden (The Netherlands) and Essen (Germany)
 Branch Offices: Principal European Cities.
 This document is subject to change

Printed in Europ

Series F62SA Airflow Switch

Introduction

The F62 airflow switch detects air flow or the absence of air flow by responding only to the velocity of air movement within a duct. The control can be wired to open one circuit and close a second circuit (SPDT) for either signaling or interlock purposes. Failure of air flow during normal operation of air handling systems may cause over-heating, coil icing and other conditions that may be detrimental to the equipment.

Typical applications include make-up air systems, air cooling or heating processes and exhaust systems.

Note

These controls are designed for use only as operating controls. Where an operating control failure would result in personal injury or loss of property, it is the responsibility of the installer to add devices or systems that protect against, or warn of, control failure.



F62SA Airflow Switch.

Feature and Benefits

- | | |
|---|--|
| <input type="checkbox"/> Polycarbonate IP43 enclosure | Allows for use in indoor and outdoor applications. |
| <input type="checkbox"/> Large wiring space | Makes wiring convenient and easily accessible. |
| <input type="checkbox"/> Range screw easily accessible | Easy to adjust in the field |

Installation

The F62SA has a polycarbonate IP43 enclosure with an integral mounting plate and can be mounted on indoor as well as outdoor applications. A mounting plate gasket is supplied with each control. The control can be mounted on top or side of a duct in a horizontal position whenever possible. Mounting at the bottom is possible but migration of dust inside the control must be avoided. If vertical duct mounting is required an upward airflow is preferred. The arrow on the cover must point in the flow direction.

Caution

If downward air flow is necessary the control must be readjusted. The adjustment procedure is indicated in the Instruction Sheet packed with each control.

Avoid locations close to elbows, dampers, fans and duct openings or other areas where excessive turbulence occurs. The control should be mounted away from such areas at a distance of at least five times the smallest duct dimension. The small paddle fits into ducts of 75 x 200 mm minimum. The paddle may be trimmed for installing in ducts as small as 75 x 150 mm.

Flow rates

Note : Please note that the given airflow velocities are approximate data obtained in laboratory tests based on a standard airdensity of 1.2 kg/m³ and are not necessarily representative or accurate when compared with various field applications.

Wiring

The SPDT switch has number coded terminals. (See Fig. 2)

Contact function

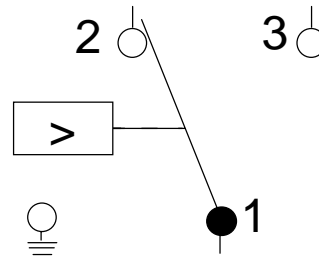

Fig. 1
1-3 closes on flow increase.

Adjustment

The switches are factory set at minimal flow setting. On the application the setting can be adjusted by the range screw under the cover as indicated in fig. 2. For higher flow rates turn the adjusting screw clockwise.

Note

Prevent to adjust the setting below factory setting as this may result in the switch failing to return to “no flow” position.

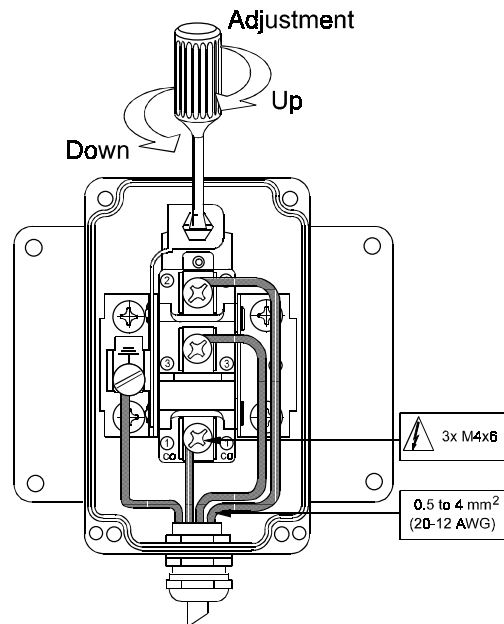

Fig. 2

Flow rate table

Paddle width	Switch actuation on flow	Minimum air velocity in m/s, required to actuate control			
		Horizontal flow		Vertical flow(upward)	
		325 cm ² or larger duct area	Less than 325 cm ² duct area	325 cm ² or larger duct area	Less than 325 cm ² duct area
55 mm	Increase 1 - 3 closes	3.2	2.9	4.8	3.8
	Decrease 1 - 2 closes	1.7	1.1	4.3	2.9
80 mm	Increase 1 - 3 closes	2.5	1.8	3.8	2.5
	Decrease 1 - 2 closes	1.3	0.5	3.3	1.8

Accessories

Replacement paddles

number	dimensions
PLT112-1R	55 x 175 mm
PLT112-2R	80 x 175 mm

Repair and replacement

Repair is not possible. In case of an improperly functioning control, please check with your nearest supplier. When contacting the supplier for a replacement you should state the type/model number of the control. This number can be found on the data plate or cover label.

Dimensions

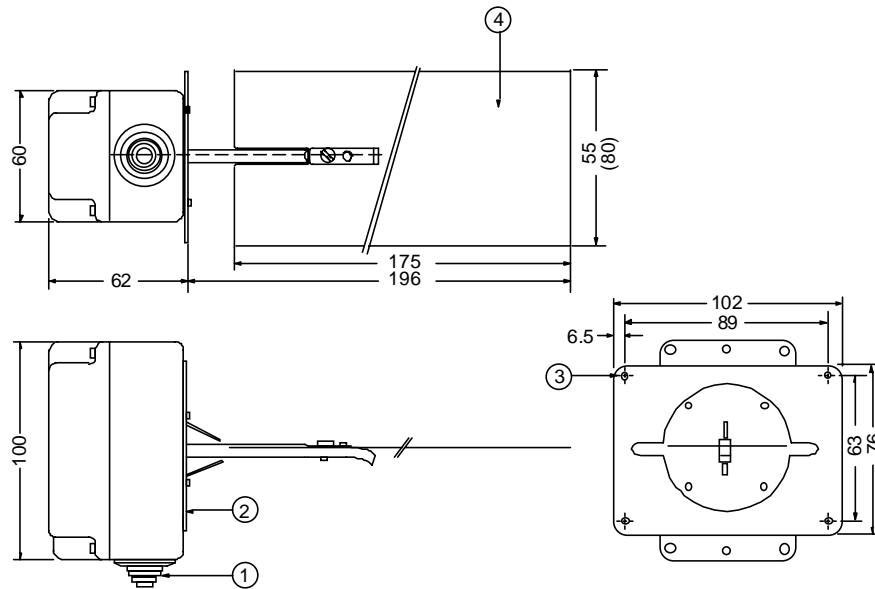

Fig. 3

- 1 Cable inlet hole $\varnothing 22.3$ mm: Grommet is installed
- 2 Mounting plate gasket 0.2 mm thick neoprene cell rubber
- 3 Four mounting holes $\varnothing 5$ mm.
- 4 One paddle 55 mm wide (mounted)
One paddle 80 mm wide (packed with the control)

Specifications

Type number	F62SA-9100
Flow rates	See flow rate table
Max. air velocity	10 m/sec
Max. air temperature*	80 °C
Min. air temperature	4 °C
Max. ambient temp.	55 °C
Min. ambient temp.	0 °C
Ambient humidity	10 to 95% R.H. (non-condensing)
Contact type	SPDT snap-acting switch
Electrical rating	15(8)A 230V ac
Wiring connections	Screw terminals 1 up to 2.5 mm ²
Enclosure	IP43
Materials	
case/cover	Polycarbonate
mounting plate	Steel zinc-plated
paddle	Stainless steel
Shipping weight	
ind. pack	0.9 kg
overbox	9 kg (10 pcs.)
Vibration	Acc. to DIN 89011 Kennlinie 1

* Max. dependent on ambient temperature. Temperature at switch should never be above 55 °C.
The performance specifications are nominal and conform to acceptable industry standards. For applications at conditions beyond these specifications, consult the local Johnson Controls office or representative. Johnson Controls shall not be liable for damages resulting from misapplication or misuse of its products.

**JOHNSON
CONTROLS**

Johnson Controls International, Inc.

Headquarters: Milwaukee, WI, USA
 European Headquarters: Westendhof 8, 45143 Essen, Germany
 European Factories: Lomagna (Italy), Leeuwarden (The Netherlands) and Essen (Germany)
 Branch Offices: Principal European Cities.

This document is subject to change

Printed in Europe

Series F63

Liquid Level Float Switches for Open or Closed Tanks

Introduction

The F63 is a liquid level float switch for use in open or closed tanks where a desired liquid level has to be maintained. They can be used in open or closed tanks and installations handling water, swimming pool water, sea water, brine, ethylene glycol or other liquids not harmful to the specified materials. The switches have SPDT contacts and can be wired to close one circuit and open a second circuit when the liquid level rises above or falls below the required level. The switch maintains the liquid level within (approx.) 13 mm.

There are three different types available. The phosphor bronze bellows version for use in applications where the liquid is not corrosive to phosphor bronze. The stainless steel bellows version for use in environments like cooling towers (water with high calcium content) and a complete stainless steel AISI 316L version. All materials in contact with the liquid are specified in the part "specifications". At doubt about the liquid used with regards to these materials it is advised to contact the liquid supplier. These float switches should not be used for liquids lighter than water (density less than 0.95 kg/dm³).



F63 Float Switch

Feature and Benefits

<input type="checkbox"/> Solid polycarbonate float	Will not accumulate liquid and provides dependable level detection.
<input type="checkbox"/> Vapour tight IP 67 enclosure	Allows for use in indoor and outdoor as well as low temperature applications
<input type="checkbox"/> Convenient wiring terminals	Makes wiring convenient and easily accessible.
<input type="checkbox"/> Three models	For many different types of liquids

Note

These controls are designed for use only as operating controls. Where an operating control failure would result in personal injury or loss of property, it is the responsibility of the installer to add devices or systems that protect against, or warn of, control failure.

Caution

Do not use with hazardous fluids or in hazardous atmosphere.

Installation

To allow the switch to respond to changes in the liquid levels, the float must not touch the side of the tank or any other obstructions. Install the F63 in a 1" threaded horizontal tank opening (see " specifications") at the height where the liquid level is to be maintained. Position the switch with the arrow on the enclosure pointing "up" for proper operation. A special vapour proof PG-16 nipple for cable inlet is delivered with the control. This nipple has to be used to keep the control vapour tight.

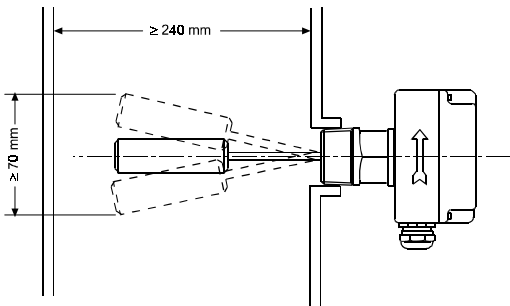

Fig. 1

Wiring

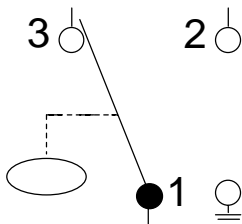

Fig. 2
Contact function
1 to 2 closes on liquid level rise.

Suggested circuits for controlling "Fill" and "Dump" levels with larger differences between minimum and maximum levels.

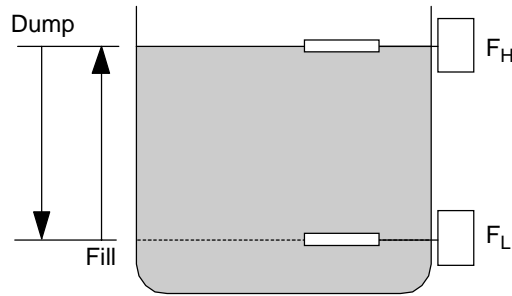

Fig. 3

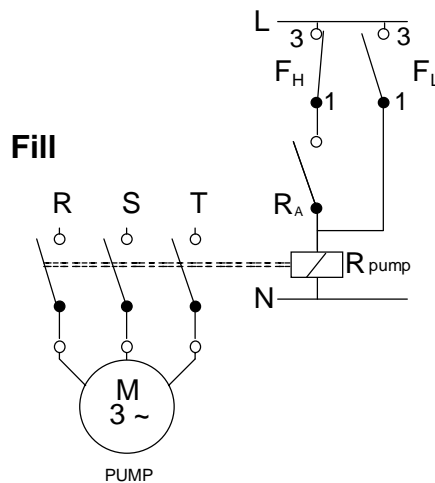

Fig. 4

R_A = Aux. contact pump relay

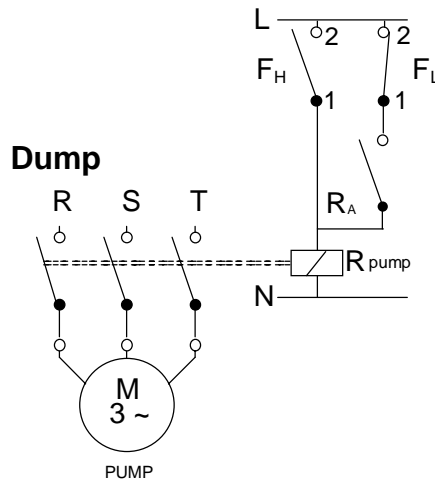

Fig. 5

Adjustment

All F63 versions are factory set and sealed. No field adjustments are required.

Repair and replacement

Repair is not possible. In case of an improperly functioning control, please check with your nearest supplier. When contacting the supplier for a replacement you should state the type/model number of the control. This number can be found on the data plate or cover label.

Type number selection table

Order number	Type	Used for
F63BT-9101	Brass body Phosphor bronze bellows	water, sea water, ethylene glycol, brine
F63BT-9102	Brass body Stainless steel bellows	cooling tower applications
F63BT-9200	Stainless steel body Stainless steel bellows	swimming pools

Dimensions

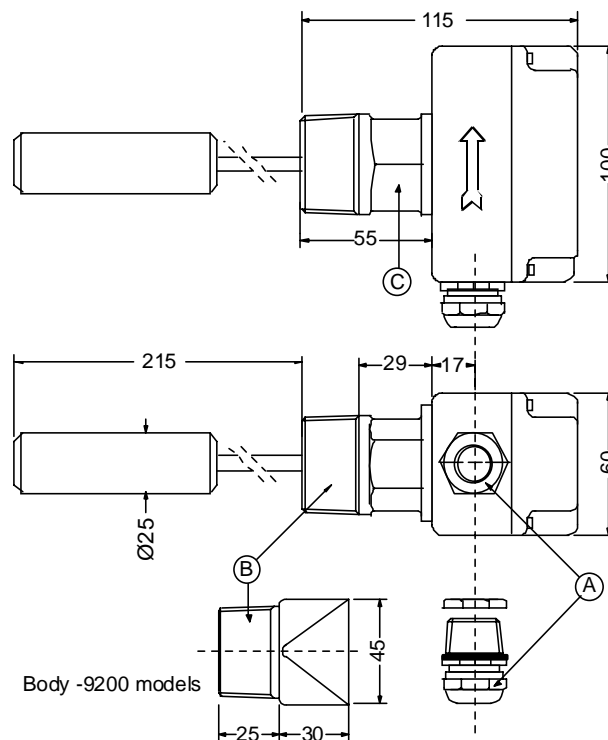

Fig. 6

A . Cable inlet hole \varnothing 22.3 mm Vapour proof PG-16 nipple

	B	C (HEX)
F63BT-9101	1-11½ NPT	34 mm
F63BT-9102	1-11½ NPT	34 mm
F63BT-9200	R1" DIN 2999 (ISO R7)	45 mm

Specifications

Type number	F63BT-9101	F63BT-9102	F63BT-9200
Pipe connection	1-1½ NPT	1-1½ NPT	R1" DIN 2999(ISO R7)
Max liquid pressure	10 bar	10 bar	10 bar
Max. liquid temperature*	100°C	100°C	100°C
Min. liquid temperature**	-30°C	-30°C	-30°C
Max. ambient temp.*	+55°C	+55°C	+55°C
Min. ambient temp.**	-40°C	-40°C	-40°C
Ambient humidity	Vapour proof	Vapour proof	Vapour proof
Contact type	SPDT snap-acting switch	SPDT snap-acting switch	SPDT snap-acting switch
Electrical rating	15(8) A 230Vac	15(8) A 230Vac	15(8) A 230Vac
Wiring connections	screw terminals 1 up to 2.5mm ²	screw terminals 1 up to 2.5mm ²	screw terminals 1 up to 2.5mm ²
Maintains liquid level within(approx)	13 mm	13 mm	13 mm
Enclosure	IP67	IP67	IP67
Materials cover / case	Polycarbonate	Polycarbonate	Polycarbonate
Materials in contact with liquid			
float	Polycarbonate	Polycarbonate	Polycarbonate
bellows	phosphor bronze CuSn 6	stainless steel AISI 316L DIN1.4404	stainless steel AISI 316L DIN1.4404
rod	bronze ASTM B140-alloy 316	bronze ASTM B140-alloy 316	stainless steel AISI 316 DIN1.4401
body	brass ASTM B584 alloy C84400	brass ASTM B584 alloy C84400	stainless steel AISI 316 DIN1.4401
washer	brass ASTM B36 alloy C23000	brass ASTM B36 alloy C23000	stainless steel AISI 316 DIN1.4401
silver solder	L-Ag45	L-Ag45	none
softsolder	L-SnAg5	L-SnAg5	none
Shipping weight individual pack	0.85 kg	0.85 kg	1.0 kg
overbox (7 pcs)	7 kg	7 kg	-
Vibration	acc.to DIN 89011 Kennlinie I		

* The max. liquid temperature of 100°C is at 20°C ambient. At higher ambient temperatures the max. allowed liquid temp. becomes lower. The temperature of the electrical switch inside should not exceed 70°C.

** The low liquid temperature combined with a low ambient temp. should not lead to freezing of the liquid inside the body / bellows. Please observe the liquid freezing point.

The performance specifications are nominal and conform to acceptable industry standards. For applications at conditions beyond these specifications, consult the local Johnson Controls office or representative. Johnson Controls shall not be liable for damages resulting from misapplication or misuse of its products.

**JOHNSON
CONTROLS**

Johnson Controls International, Inc.

Headquarters: Milwaukee, WI, USA
 European Headquarters: Westendhof 8, 45143 Essen, Germany
 European Factories: Lomagna (Italy), Leeuwarden (The Netherlands) and Essen (Germany)
 Branch Offices: Principal European Cities.

This document is subject to change

Printed in Europe

Series P20

Pressure Controls for Refrigeration, Air-conditioning and Heat-pump Applications

Introduction

The P20 series high and low limit (cut-out) controls for all non-corrosive refrigerants are compact pressure controls ideally suited for commercial or residential packaged air conditioning units, heat pumps, small water chillers, ice cube machines and other applications where a semi fixed setting is acceptable or required and where mounting space is limited. The P20 series includes auto reset as well as manual reset models and is factory set. A special setting tool is available for field adjustability. There are also models available for HP R410a applications. All the HP models are tested and approved according to the PED 97/23EC Cat. IV. Individual packed universal replacement models are provided with a second suffix number "C"



P20 Pressure Control

Feature and Benefits	
<input type="checkbox"/> Field proven reliability.	More than half a million in use today.
<input type="checkbox"/> Reset tab must be released before restart. (Trip free manual reset).	Override of control function is not possible.
<input type="checkbox"/> Compact design.	Less cabinet space needed.
<input type="checkbox"/> Enclosed dust-tight switch.	Prevents contacts pollution.
<input type="checkbox"/> SPDT contact with special terminals.	Can be used either as quick or as screw terminals.
<input type="checkbox"/> Test pressure 53 bar.	Test strength far above severe operating and standby conditions.
<input type="checkbox"/> Designed for at least 200000 cycles.	Accurate repeatability and long life.

Note

The controls are intended to control equipment under normal operating conditions. Where failure or malfunctioning of the controls could lead to an abnormal operating condition that could cause personal injury or damage to the equipment or other property, other devices (limit or safety controls) or systems (alarm or supervisory systems) intended to warn of or protect against failure or malfunctioning of the controls must be incorporated into and maintained as part of the control system.

Description

The P20 series are available in three categories (see type number selection table):

- 1) **Universal replacement models.** These models are individually packed and can be purchased in any quantity. The models are provided with an extra second suffix number "C"
The models are field adjustable by use of the special wrench WRN12-1 (must be ordered separately)
- 2) **Basic models.** These are factory set but can be adjusted by use of a special wrench (see accessories). They can be purchased in bulkpack of 50 pcs each.
- 3) **Special (OEM) models.** For yearly order quantities above 1000 pcs these models can have optional constructions like:
 - screwdriver adjustment (Not PED approved)
 - 120 cm capillary
 - range -0.6 to 7 bar
 - range 14 to 42 bar (R410a applications)
 - other pressure connection style

The minimum shipping quantity from factory is 250 pieces per model (5 boxes). Please contact your Johnson Controls representative.

Installation

The P20 controls can be installed in any convenient location provided that the ambient conditions are suitable for the IP00 enclosure, within the specified limits regarding temperature and humidity and normal pollution situation. Each control is provided with 2 mounting screws (6-32UNC x 4.5 mm thread). For easy mounting different types of mounting brackets are available (see accessories).

Adjustment

All models are factory set. Models can be field adjusted by use of a special wrench (see accessories). The differential is not adjustable but can be selected from the "Differential Specifications" matrices (see page 4).

Range

The indicated range means from the "minimal low switchpoint" up to the maximum "high switchpoint". This means that the "differential" cannot be at the outside of the indicated range.

Contact functions

Low Pressure version

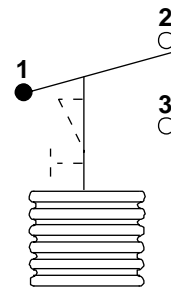

1 - 2 open on pressure decrease

Fig.1

High Pressure version

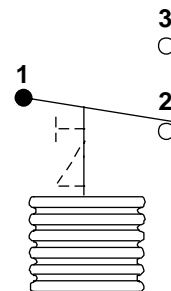

1 - 2 open on pressure increase

Fig. 2

Accessories (see page 6 and 7).

The following accessories are available:

- Adjusting wrench WRN12-1 for adjustment of all models. (Fig. 8)
- Clip-on terminal cover. (Fig. 9)
- Mounting plate BKT116-1 for single P20. (Fig. 10)
- Mounting bracket 210-25R for single P20, angled version. (Fig. 11)
- Mounting bracket BKT275-1 for two P20 controls, angled version. (Fig. 12)

Type number selection

In the model number the following information is given:

P20EA-9650K

E = Auto reset

F = Manual reset lockout low

G = Manual reset lockout high

A = Basic and universal models (only adjustable with special wrench)

L = Provided with bellows for R410a application (HP only)

Pressure connection style (see page 6)

1 = style 45A

5 = style 50, 51 or customer special

6 = style 13

9 = style 34

Pressure differential. This is indicated in the "Differential Specification" matrices (see page 4,5). The differential code is indicated by two characters. Each differential code compares with a digit as indicated below. (Not valid for manual reset models).

Differential digit in model number	Differential code	
1	AL	LP models
2	BL	
3	CL	
4	DL	
5	AM	HP models
6	BM	
7	CM	
8	DM	
6	BR	HP (R410a) models
7	CR	
8	DR	

This is the model number suffix that indicates the selected switch point (see "Differential Specification" matrices, page 4 - horizontal line). The figures given at the intersection of this horizontal line and the selected differential column indicates the pressure differential that belongs to the selected switch point. The model suffix is indicated in the "Differential Specification" matrices (see page 4,5).

The above mentioned model P20EA-9650K indicates:

Auto reset

Basic model (special adjustment tool WRN12-1 needed)

Connection style 13

Differential AM equals 1.2 bar

High switch point 16 bar.

Differential specification matrix for LP models, values in bar.

Low switch point	Differential code				Model suffix
	AL (1)	BL (2)	CL (3)	DL (4)	
0.5	0.9	1.5	2.0	2.6	A
1	0.9	1.5	2.0	2.6	B
1.5	0.9	1.5	2.0	2.7	C
2	0.9	1.5	2.1	2.7	D
2.5	0.9	1.5	2.1	2.8	E
3	0.9	1.5	2.1	2.8	F
3.5	0.9	1.5	2.1	2.8	G
4	0.9	1.5	2.1	2.9	H
4.5	0.9	1.5	2.1	2.9	K
5	0.9	1.5	2.1	3.0	L
5.5	1.0	1.6	2.2	3.0	M
6	1.0	1.6	2.2	3.0	N
6.5	1.0	1.6	2.2	3.1	P
7	1.0	1.6	2.2	3.1	Q
7.5	1.0	1.6	2.2	X	R
8	1.0	1.6	X	X	S

Differential specification matrix for HP models, values in bar.

High switch point	Differential code				Model suffix
	AM (5)	BM (6)	CM (7)	DM (8)	
8	1.0	X	X	X	A
9	1.1	X	X	X	B
10	1.1	2.8	X	X	C
11	1.1	2.8	4.2	X	D
12	1.1	2.9	4.3	X	E
13	1.2	2.9	4.3	6.1	F
14	1.2	2.9	4.4	6.2	G
15	1.2	3.0	4.4	6.3	H
16	1.2	3.1	4.5	6.4	K
17	1.2	3.1	4.6	6.5	L
18	1.3	3.1	4.6	6.5	M
19	1.3	3.1	4.7	6.6	N
20	1.3	3.2	4.7	6.7	P
21	1.3	3.2	4.8	6.8	Q
22	1.3	3.3	4.9	6.9	R
23	1.4	3.3	4.9	7.0	S
24	1.4	3.3	5.0	7.1	T
25	1.4	3.4	5.0	7.2	U
26	1.4	3.4	5.1	7.3	V
27	1.4	3.5	5.2	7.4	W
28	1.5	3.5	5.2	7.5	X
29	1.5	3.5	5.2	7.6	Y

Differential tolerances*:

AL ± 50 %	CL ± 26 %
BL ± 34 %	DL ± 20 %
AM ± 30 %	CM ± 21 %
BM ± 24 %	DM ± 18 %

* But not less than 0.4 bar.

Switch point tolerances LP models ± 3 % but not less than 0.2 bar.

Switch point tolerances HP models ± 2 % but not less than 0.4 bar.

Differential specification matrix for R410a/HP models, values in bar.

High switch point	Differential code			Model suffix
	BR (6)	CR (7)	DR (8)	
18	3,8	X	X	A
19	3,8	X	X	B
20	3,8	6,0	X	C
21	3,8	6,0	X	D
22	3,8	6,1	7,8	E
23	3,8	6,1	7,9	F
24	3,8	6,1	8,0	G
25	3,9	6,2	8,0	H
26	3,9	6,2	8,1	I
27	3,9	6,2	8,2	J
28	3,9	6,3	8,3	K
29	3,9	6,3	8,3	L
30	3,9	6,3	8,4	M
31	3,9	6,3	8,4	N
32	3,9	6,4	8,5	O
33	4,0	6,4	8,6	P
34	4,0	6,4	8,7	Q
35	4,0	6,4	8,7	R
36	4,0	6,5	8,8	S
37	4,0	6,5	8,9	T
38	4,0	6,5	9,0	U
39	4,0	6,5	9,0	V
40	4,0	6,5	9,1	W
41	4,0	6,5	9,2	X
42	4,0	6,5	9,2	Y

Differential tolerances*:

BR ± 0,9 bar

CR ± 1,1 bar

DR ± 1,5 bar

Switch point tolerances R410a/HP models ± 0,7 bar.

Type number selection table

Universal replacement models

Range(*) (bar)	Differential code	Pressure connector	Contact function	Factory set at	Max. working pressure	Order number
0.5 - 10	CL	style 50	Fig. 1	3 bar	20 bar	P20EA-9530FC
0.5 - 10	CL	style 13	Fig. 1	3 bar	20 bar	P20EA-9630FC
7 - 29	CM	style 51	Fig. 2	28 bar	38 bar	P20EA-9570XC
7 - 29	CM	style 13	Fig. 2	28 bar	38 bar	P20EA-9670XC
14 - 42	CR	style 13	Fig. 2	37 bar	48 bar	P20EL-9670TC
0.5 - 10	man. reset ⁽¹⁾	style 50	Fig. 1	3 bar	20 bar	P20FA-9510FC
0.5 - 10	man. reset ⁽¹⁾	style 13	Fig. 1	3 bar	20 bar	P20FA-9610FC
7 - 29	man. reset ⁽²⁾	style 50	Fig. 2	28 bar	38 bar	P20GA-9550XC
7 - 29	man. reset ⁽²⁾	style 13	Fig. 2	28 bar	38 bar	P20GA-9650XC
14 - 42	man. reset ⁽²⁾	style 13	Fig. 2	37 bar	48 bar	P20GL-9650TC

Type number selection table (continued)

Range(*) (bar)	Differential code	Pressure connector	Contact function	Factory set at	Max. working pressure	Order number
-------------------	----------------------	-----------------------	---------------------	-------------------	-----------------------------	--------------

Low pressure, auto reset models

0.5 - 10	AL	style 13	Fig. 1	(**)	20 bar	P20EA-9610 (**)
0.5 - 10	BL	style 45A	Fig. 1	(**)	20 bar	P20EA-9120 (**)
0.5 - 10	BL	style 13	Fig. 1	(**)	20 bar	P20EA-9620 (**)
0.5 - 10	CL	style 45A	Fig. 1	(**)	20 bar	P20EA-9130 (**)
0.5 - 10	CL	style 13	Fig. 1	(**)	20 bar	P20EA-9630 (**)
0.5 - 10	DL	style 13	Fig. 1	(**)	20 bar	P20EA-9640 (**)
0.5 - 10	AL	style 34	Fig. 1	(**)	20 bar	P20EA-9910 (**)
0.5 - 10	BL	style 34	Fig. 1	(**)	20 bar	P20EA-9920 (**)
0.5 - 10	CL	style 34	Fig. 1	(**)	20 bar	P20EA-9930 (**)
0.5 - 10	DL	style 34	Fig. 1	(**)	20 bar	P20EA-9940 (**)

Low pressure, manual reset models

0.5 - 10	man. reset ⁽¹⁾	style 13	Fig. 1	(**)	20 bar	P20FA-9610 (**)
----------	---------------------------	----------	--------	------	--------	-----------------

High pressure, auto reset models

7 - 29	AM	style 13	Fig. 2	(**)	38 bar	P20EA-9650(**)
7 - 29	BM	style 45A	Fig. 2	(**)	38 bar	P20EA-9160(**)
7 - 29	BM	style 13	Fig. 2	(**)	38 bar	P20EA-9660(**)
7 - 29	CM	style 45A	Fig. 2	(**)	38 bar	P20EA-9170(**)
7 - 29	CM	style 13	Fig. 2	(**)	38 bar	P20EA-9670(**)
7 - 29	DM	style 13	Fig. 2	(**)	38 bar	P20EA-9680(**)
7 - 29	AM	style 34	Fig. 2	(**)	38 bar	P20EA-9950(**)
7 - 29	BM	style 34	Fig. 2	(**)	38 bar	P20EA-9960(**)
7 - 29	CM	style 34	Fig. 2	(**)	38 bar	P20EA-9970(**)
7 - 29	DM	style 34	Fig. 2	(**)	38 bar	P20EA-9980(**)

High pressure, manual reset models

7 - 29	man. reset ⁽²⁾	style 45A	Fig. 2	(**)	38 bar	P20GA-9150(**)
7 - 29	man. reset ⁽²⁾	style 50	Fig. 2	(**)	38 bar	P20GA-9550(**)
7 - 29	man. reset ⁽²⁾	style 13	Fig. 2	(**)	38 bar	P20GA-9650(**)
7 - 29	man. reset ⁽²⁾	style 34	Fig. 2	(**)	38 bar	P20GA-9950(**)

High pressure, auto reset models for R410a applications

14-42	BR	style 13	Fig. 2	(**)	48 bar	P20EL-9660(**)
14-42	BR	style 45A	Fig. 2	(**)	48 bar	P20EL-9160(**)
14-42	BR	style 34	Fig. 2	(**)	48 bar	P20EL-9960(**)
14-42	CR	style 13	Fig. 2	(**)	48 bar	P20EL-9670(**)
14-42	CR	style 45A	Fig. 2	(**)	48 bar	P20EL-9170(**)
14-42	CR	style 34	Fig.2	(**)	48 bar	P20EL-9970(**)
14-42	DR	style 13	Fig.2	(**)	48 bar	P20EL-9680(**)
14-42	DR	Style 45a	Fig.2	(**)	48 bar	P20EL-9180(**)
14-42	DR	style 34	Fig. 2	(**)	48 bar	P20EL-9980(**)

High pressure, manual reset models for R410a applications

14-42	man. reset ⁽²⁾	style 13	Fig. 2	(**)	48 bar	P20GL-9650(**)
14-42	man. reset ⁽²⁾	style 45A	Fig. 2	(**)	48 bar	P20GL-9150(**)
14-42	man. reset ⁽²⁾	style 34	Fig. 2	(**)	48 bar	P20GL-9950(**)

(*) Minimum low switch point to maximum high switch point.

(1) Reset possible ≥ 3 bar above low switch point(2) Reset possible ≥ 7 bar below high switch point.

(**) When ordering specify setting by adding the model suffix.

Repair and replacement

Repair is not possible. In case of an improperly functioning control, please check with your nearest supplier. When contacting the supplier

for a replacement you should state the type/model number of the control. This number can be found on the data plate

Pressure connections

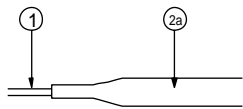

Fig. 3

Style 34

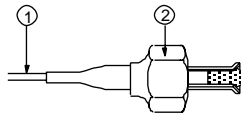

Fig. 4

Style 45A (incl. valve depressor mounted into capillary flare section)

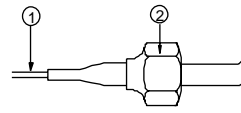

Fig. 5

Style 13 (without valve depressor)

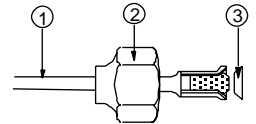

Fig. 6

Style 50 (incl. valve depressor mounted into machined flare)

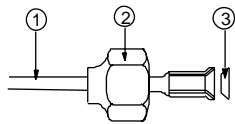

Fig. 7

Style 51 (machined flare excl. valve depressor)

1. 90 cm capillary.
2. 7/16 - 20 UNF flare nut.
- 2a. 1/4" tube ODM for braze connection.
3. copper seal ring

Accessories (optional, has to be ordered separately)

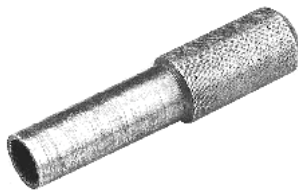

Fig. 8
Adjusting wrench
WRN12-1

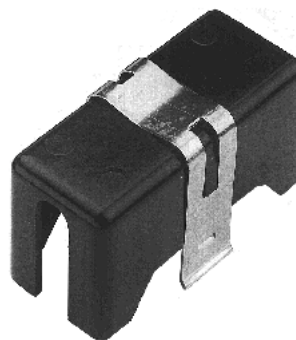

Fig. 9
Clip-on Bakelite terminal
cover 210-604R

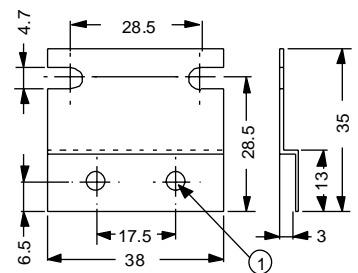

Fig. 10
Mounting plate BKT116-1
(single)
1. mounting holes
For P20 Ø 4mm

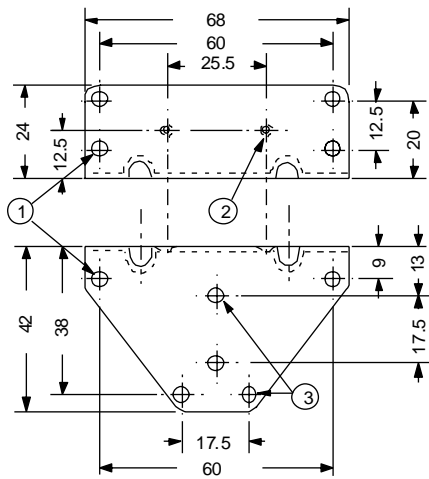

Fig. 11
Mounting bracket 210-25R (single)

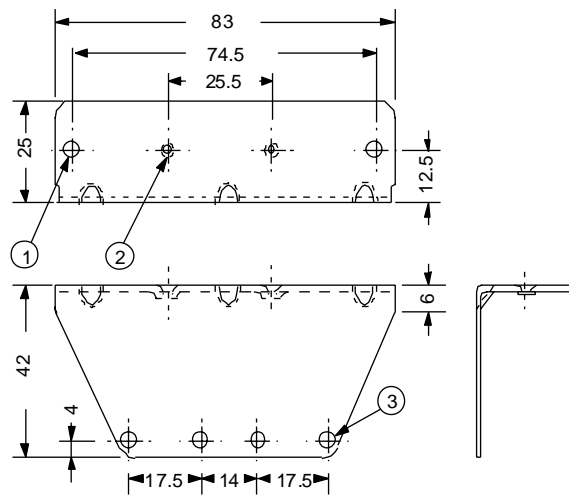
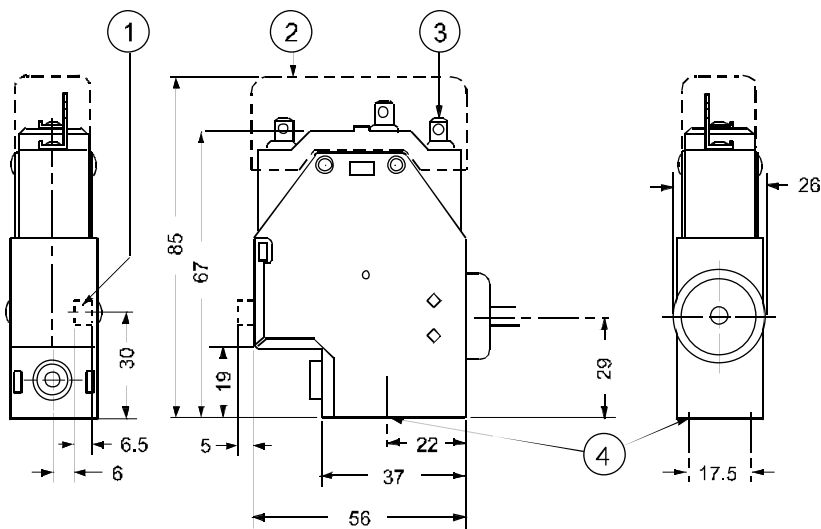

Fig. 12
Mounting bracket BKT275-1 (dual)

- 1 Mounting holes \varnothing 4 mm
- 2 Extruded holes 8 - 32 UNC thread
- 3 Mounting holes for P20 \varnothing 4 mm

Dimensions Standard Controls (mm)



- 1 Reset lever, for manual reset models only
- 2 Height of control if 210-604R is used.
- 3 Terminals can be used as quick connectors (6.3 mm) as well as screw connections.
- 4 2 Mounting holes 6 - 32 UNC thread (2 screws 6-32UNC x 4,5 mm provided with each control).

Fig. 13

Dimensions R410a (HP) models(mm)

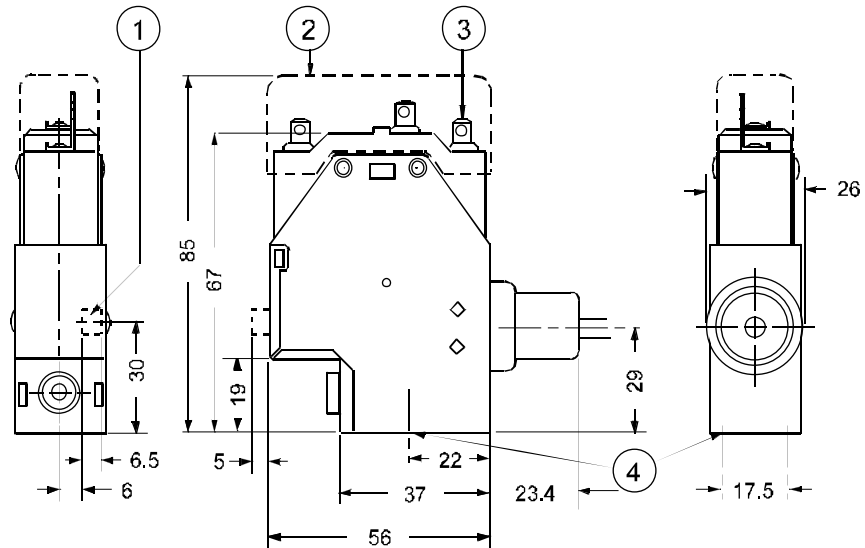

- 1 Reset lever, for manual reset models only
- 2 Height of control if 210-604R is used.
- 3 Terminals can be used as quick connectors (6.3 mm) as well as screw connections.
- 4 2 Mounting holes 6 - 32 UNC thread (2 screws 6-32UNC x 4,5 mm provided with each control).

Fig. 14

Specifications

Type number	See type number selection table (page 5)	
Operating range	LP models	0.5 - 10 bar
	HP models	7 - 29 bar
	R410a/HP models	14 - 42bar
Pressure connections	90 cm capillary, styles 13, 34, 45A,50 and 51	
Switch points and differentials	See "Differential specification" matrices (page 4,5)	
Adjustment	Wrench adjustment	
Maximum ambient temp.	+55 °C	
Minimum ambient temp.	-35°C	
Ambient humidity	10 to 95% RH (non-condensing)	
Test pressure	53 bar max.	
Minimum burst pressure	200 bar	
Protection class	IP00	
Electrical rating	15(8)A 230 V ac	
Contact	SPDT snap-acting switch	
Wiring connections	Screw terminals 1 up till 2.5 mm ² . Quick connector type 6.3 mm	
Material case	Cold rolled steel, zinc plated with dichromate dip	
capillary	Copper	
Packaging	50 controls per box	
Shipping weight	15 kg per box	
Dimensions	See dimension drawings	

Note: 1 bar = 100 kPa ≈ 14.5 psi.

The performance specifications are nominal and conform to acceptable industry standards. For applications at conditions beyond these specifications, consult the local Johnson Controls office or representative. Johnson Controls shall not be liable for damages resulting from misapplication or misuse of its products.



Johnson Controls International, Inc.

Headquarters: Milwaukee, WI, USA
 European Headquarters: Brussels, Belgium
 European Factories: Lomagna (Italy), Leeuwarden (The Netherlands) and Essen (Germany)
 Branch Offices: Principal European Cities.

This document is subject to change

www.johnsoncontrols.com
 Printed in Europe

Series P233A/F series

Sensitive (differential) Pressure Switch for Air

Introuction

This (differential) pressure switch is used to sense flow of air, single or differential air pressure.

Typical applications include:

- Detect clogged filter
- Detect frost or ice build-up on air conditioning coils
- Air proving in heating or ventilation ducts.
- Maximum airflow controller for variable air volume system.
- Detect blocked flue or vent
- Monitor fan operation



Series P233A Sensitive Pressure switch for Air

Description

This switch senses a change in the (differential) pressure (either velocity pressure or pressure drop across a restriction) as the airflow changes. The (differential) pressure is applied to the two sides of a diaphragm in the control. The spring-loaded diaphragm moves and actuates the switch. The series P233A/F can also be used to detect small positive gauge pressure by using only the high-

pressure connection and leaving the low-pressure port open. Or to detect a vacuum by using only the low pressure connection and leaving the high-pressure port open to ambient pressure.

Feature and Benefits	
<input type="checkbox"/> One switch to measure relative pressure, vacuum or differential pressure	Provides versatility to match various applications
<input type="checkbox"/> Various accessories available	Provides flexibility
<input type="checkbox"/> Compact and durable construction	Provides durability in combination with neutral gases
<input type="checkbox"/> Easy mounting and wiring, various mounting possibilities	Reduce installation time
<input type="checkbox"/> Standard PG 11 nipple and optional DIN 43650 connector	Provides flexibility in wiring connections
<input type="checkbox"/> Accurate and stable switch point	Provides high accuracy and repeatability
<input type="checkbox"/> SPDT contact standard	Can be used for “normally open” or “normally closed” applications

Note

These controls are designed for use only as operating controls. Where an operating control failure would result in personal injury or loss of property it is the responsibility of the installer to add devices or systems that protect against, or warn of, control failure.

Contact function

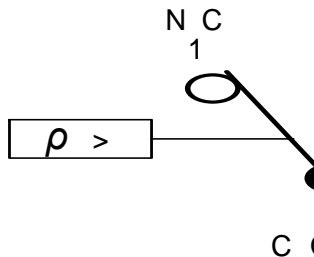

Fig. 1

Adjustment

The scale values indicate the approximate switching point at increasing pressure (contacts 3-1 to open). If accurate setting is required, the approximate setting on the scale should be corrected by using a pressure gauge.

Mounting

- Select a location where vibrations are minimal.
- When mounting in horizontal positions the following corrections should be taken into account.

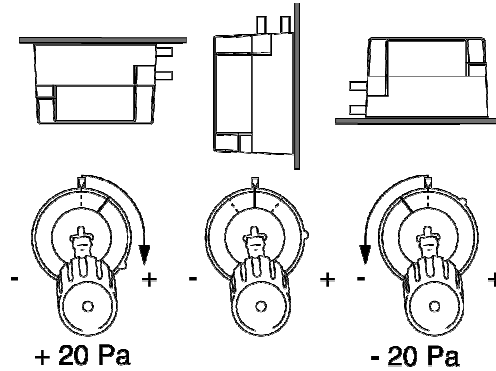

Fig. 2

Repair and replacement

Repair is not possible. In case of a defective or improperly functioning control, please check with your nearest supplier. When contacting the supplier for a replacement you should state the type/model number of the control. This number can be found on the side of the control.

Type number selection table

Order number	Setpoint range	Accessories incl.	Remarks
P233A-4-AAC	0,5 to 4 mbar	No	
P233A-4-AAD	0,5 to 4 mbar	No	Bulk pack
P233A-4-AHC	0,5 to 4 mbar	GMT008N600R + BKT024N002R	
P233A-4-AKC	0,5 to 4 mbar	FTG015N602R (2x) + 2m tube 4/7 mm	
P233A-4-PAC	50 to 400 Pa	No	
P233A-4-PAD	50 to 400 Pa	No	Bulk pack
P233A-4-PHC	50 to 400 Pa	GMT008N600R + BKT024N002R	
P233A-4-PKC	50 to 400 Pa	FTG015N602R (2x) + 2m tube 4/7 mm	
P233A-6-AAD	0,5 to 6 mbar	No	Bulk pack
P233A-10-AAC	1,4 to 10 mbar	No	
P233A-10-AAD	1,4 to 10 mbar	No	Bulk pack
P233A-10-AHC	1,4 to 10 mbar	GMT008N600R + BKT024N002R	
P233A-10-AKC	1,4 to 10 mbar	FTG015N602R (2x) + 2m tube 4/7 mm	
P233A-10-PAC	140 to 1000 Pa	No	
P233A-10-PHC	140 to 1000 Pa	GMT008N600R + BKT024N002R	
P233A-10-PKC	140 to 1000 Pa	FTG015N602R (2x) + 2m tube 4/7 mm	
P233A-50-AAC	6 to 50 mbar	No	
P233F-P3-AAD	0,3 mbar fixed setting	No	Bulk pack

Accessories



BKT024N002R
Mounting Bracket for P233A/F



GMT008N600R
Duct mounting kit

Including:
2m PVC tube 4/7 mm
2 grommets (drilling hole
16mm)



FTG015N602R
Duct mounting kit (straight)

Including:
2 mounting screws
O-ring



FTG015N603R
Duct mounting kit (bent)

Including:
2 mounting screws
O-ring

Dimensions (mm)

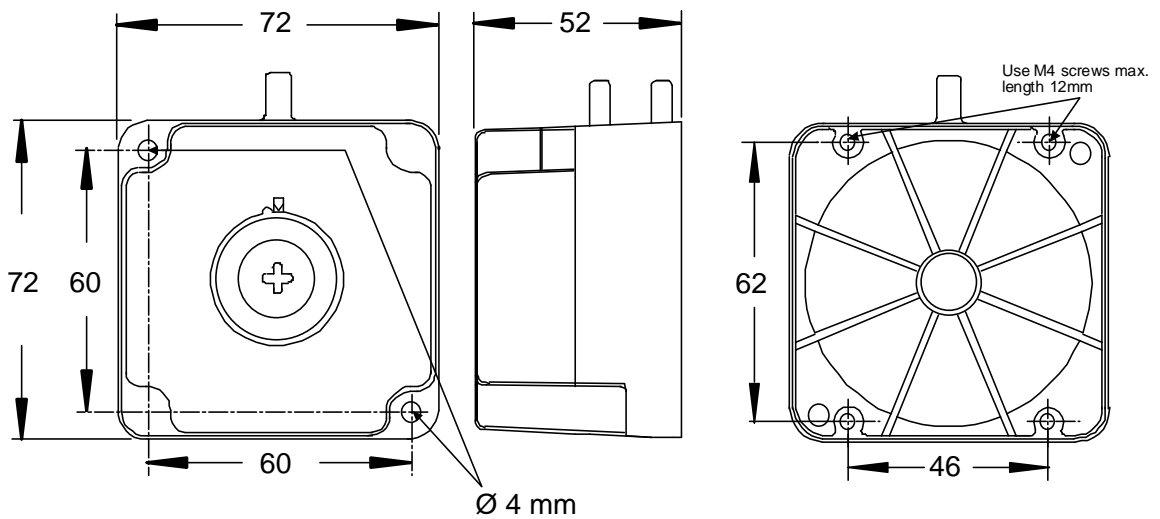

Specifications

	Setpoint range 0,5 to 4mbar	Setpoint range 1,4 to 10mbar	Setpoint range 6 to 50mbar
Differential (fixed)	≤ 0,25mbar	≤ 0,5mbar	≤ 1,2mbar
Sample media	Air, non-inflammable gases, non-aggressive gases		
Max. continuous overpressure	300 mbar		
Calibration position	With diaphragm vertical. (For horizontal position make corrections as mentioned in fig 2)		
Calibration temperature	20°C		
Operating temp. Limits	-15 to +60 °C		
Storage temperature	-35 to 60°C		
Operating/storage humidity	10 to 95%RH, non condensing		
Material	Cover:	Polycarbonate	
	Case:	Glass reinforced polycarbonate	
	Bottom:	Glass reinforced polycarbonate	
	Diaphragm:	Nitrile butadiene rubber	
	Switch:	Brass, Phosphorbronze, Silvernickel	
Weight	115 g		
	330 g For models including grommet and bracket		
Contact rating (SPDT contact)	I_{max} at 250Vac:	5A at $\cos\phi=1$; 2A at $\cos\phi=0,6$	
Life cycle	At I_{max} :	200.000 operations (@ 60°C) 50.000 operations (@ -15°C)	
Electrical connections	Screw terminals, wire diameter 0,5 to 4mm ² (Connector according DIN 43650 optional)		
Protection class	IP 54		
Approvals	73/23/EEC 89/336/EEC 90/396/EEC		

Note: 1mbar = 100 Pa = 9.8 mm WC

The performance specifications are nominal and conform to acceptable industry standards. For applications at conditions beyond these specifications, consult the local Johnson Controls office or representative. Johnson Controls shall not be liable for damages resulting from misapplication or misuse of its products.



Johnson Controls International, Inc.

Headquarters: Milwaukee, WI, USA
 European Headquarters: Westendhof 8, 45143 Essen, Germany
 European Factories: Lomagna (Italy), Leeuwarden (The Netherlands) and Essen (Germany)
 Branch Offices: Principal European Cities.
 This document is subject to change

Printed in Europe

System 27 NOVA

Modular Electronic Pressure Control System

Introduction

System 27 NOVA is a family of modern modular electronic modules designed for a wide variety of control configurations in refrigeration, heating, ventilation, air-conditioning and other related fields.

The pressure control modules can be used as a stand alone device or together with other modules, such as, stage modules, display modules, signal converter modules, etc., to achieve a diverse number of single or multistage applications.

Typical applications are:

- high pressure alarm
- condenser fan cycling
- compressor control

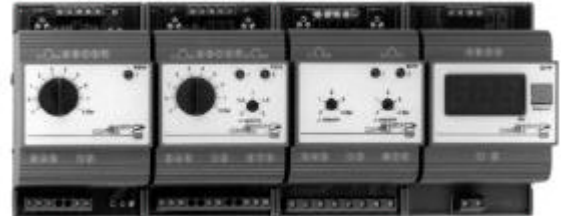

**System 27 NOVA Modular
Pressure Controls**

Description

The modular concept was specially designed to make control configuration easier and still offer the flexibility necessary to answer the many individual control requirements encountered today.

Feature and Benefits

q	Modular design	Provides the flexibility to realise the required control set up without redundancy and makes future expansion easy.
q	“Plug-in” quick connector wiring system	Eliminates wiring between modules and reduces installation cost.
q	Adjustable differential and set high/set low setting	Provides flexibility to match any combination of heating or cooling applications.
q	Various pressure sensors are available	Matches various applications.
q	Attractive DIN-rail mount housing	Easy and quick to install.
q	Setpoint shift output function	Modules can be used for “multiple setpoint” applications.

The System 27 NOVA family includes the following modules:

P27 Pressure Control Modules



These one- or two-stage pressure control modules can be used as a low cost control for stand alone applications, or as the primary control module for multiple stage applications. For this type of applications one or more stage modules can be connected to the

pressure control module very easy by using the quick connector system.

S27 Stage Modules



If multi-stage control is required one or more stage modules can be hooked up easily to a P27 pressure control module, simply by using the included quick connector. A maximum of 4 four stage modules can be connected to a pressure control module.

D27P Pressure Display Modules



A display module connected to a pressure control module gives a digital indication of the measured pressure or setpoint. It is also possible to connect a sensor directly to the D27P for pressure read-out.

Y27M Signal Converter



This module converts a voltage input signal to a standardised output signal of 0 to 10 Vdc or 4 to 20 mA. The input signal can either be obtained from a pressure sensor or a pressure control module. The signal converter can be used for those applications

where an analogue output is required. Such as; to a motor, motor actuated valve, recorder etc.

P99 Pressure Sensor



Three pressure ranges and male or female connection styles are available. For detailed information please refer to the P299 Pressure Sensor bulletin.

Note

The System 27 modules are intended to control equipment under normal operating conditions. Where failure or malfunction of the modules could lead to an abnormal operating condition that could cause personal injury or damage to the equipment or other property, other devices (limit or safety controls) or systems (alarm or supervisory systems) intended to warn of or protect against failure or malfunction of the modules must be incorporated into and maintained as part of the control system.

Application examples

At page 6 to 7 you will find some applications examples. For more detailed information about wiring and adjustment reference should be made to the installation sheet

Repair and Replacement

Repair is not possible. In case of an improperly functioning control, please check with your nearest supplier.

When contacting the supplier for a replacement you should state the type-model number of the control. This number can be found on the dataplate.

Accessories dim. in mm

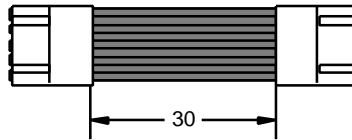

Fig. 1
WRE027N600
Quick Connector for connecting System 27 NOVA modules.

Dimensions (mm)

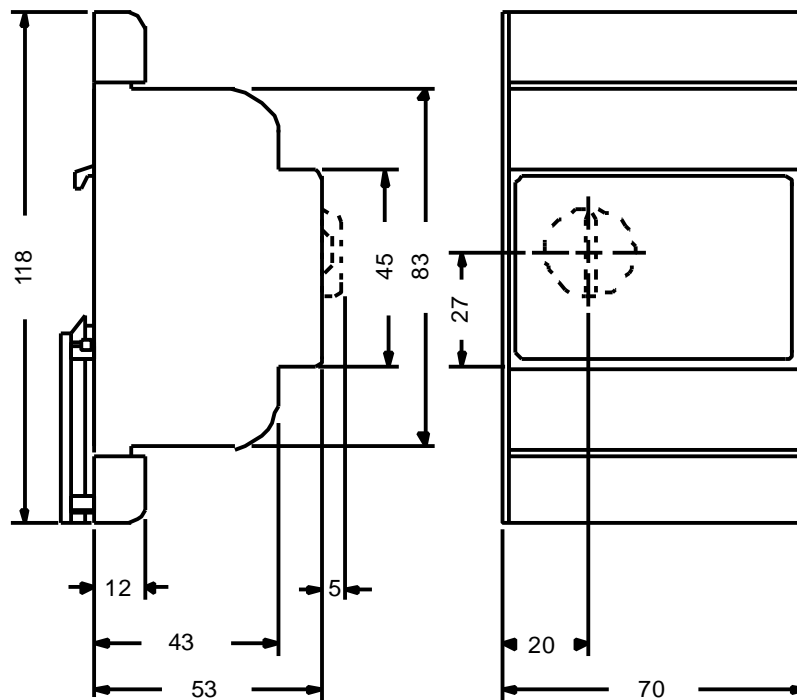
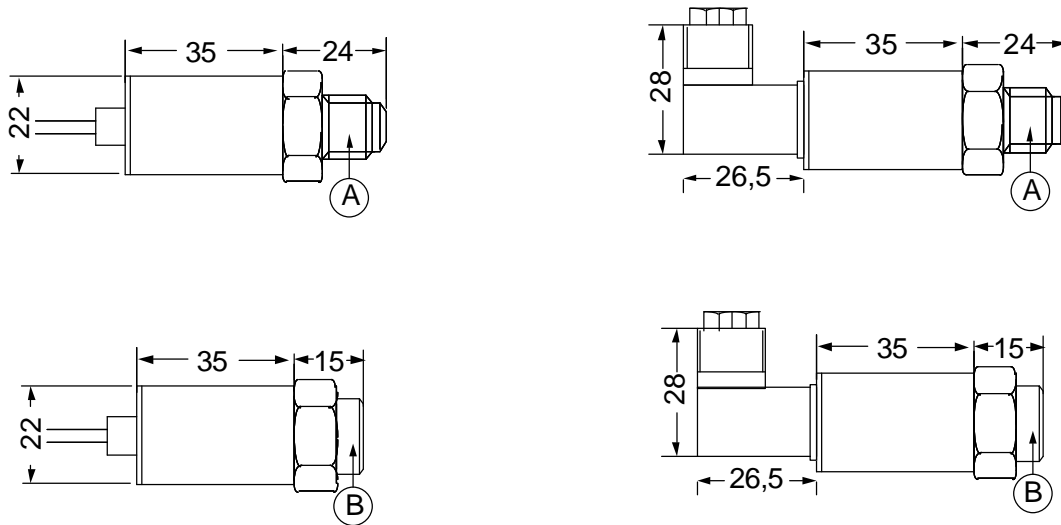

Fig. 3
System 27 NOVA Modules

Dimensions P299



A: Pressure connection male 7/16"-20UNF
B: Pressure connection female 7/16"-20UN

Type Number Selection Table

One Stage Pressure switch

Order number	Power supply	Setpoint range (bar)	Diff. (bar)	Additional
P27A2N11	230 V ac	-1 to 8	0.1 to 3.5	* Mode: field adjustable
P27A2N12	230 V ac	0 to 30	0.5 to 7	* SPDT contact 10(5)A 250 V ac

Two stage pressure switch

Order number	Power supply	Setpoint range (bar)	? setpoint between stage	Additional features
P27A2N21	230 V ac	-1 to 8	0 to 2	* 2 x SPDT contact 10 (5) A 250 V ac
P27A2N22	230 V ac	0 to 30	0 to 4	* Differential: 0.1 to 3.5 bar * Mode: field adjustable

Stage module

Order number	Power supply	Additional features
S27P2	230 V ac	* Mode: field adjustable * 2x SPDT contact 10(5)A 250V ac * Δ Setpoint: 0 to 4 bar * Differential: 0.1 to 3.5 bar * Quick connector is included

Pressure display module

Order number	Power supply	Quick connector incl.	Additional features
D27P2N3	230 V ac	no	* Can be used as stand alone or in conjunction with a pressure switch * Range -1 to 8/0 to 30 bar * Setpoint read-out

Y27M Signal Converter

Order number	Power supply	Setpoint range (Vdc)	Span range (Vdc)
Y27M1	24 V ac	0 to 10	0 to 10
Y27M2	230 V ac	0 to 10	0 to 10

Pressure sensors

Order number	Range (bar)	Output (V)	Connection (style)	Additional features
P299DVB-1C	-1 to 8	0 to 10	male	* can be used with all media
P299DVC-1C	-1 to 8	0 to 10	female	* no O- ring seals or ceramics which are susceptible to leak
P299EVB-1C	0 to 30	0 to 10	male	* IP 67
P299EVC-1C	0 to 30	0 to 10	female	* stainless steel housing

Wiring & Adjustments

**One-stage Pressure switch
P27A2N1x**

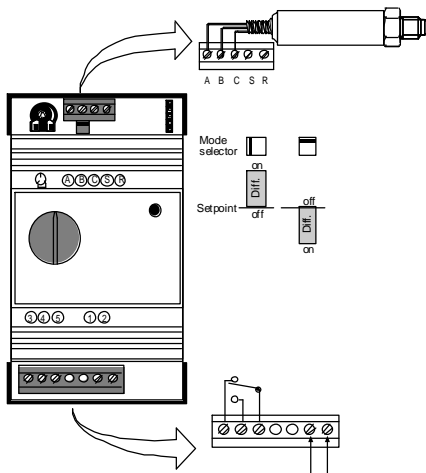

**Two-stage Pressure switch
P27A2N2x**

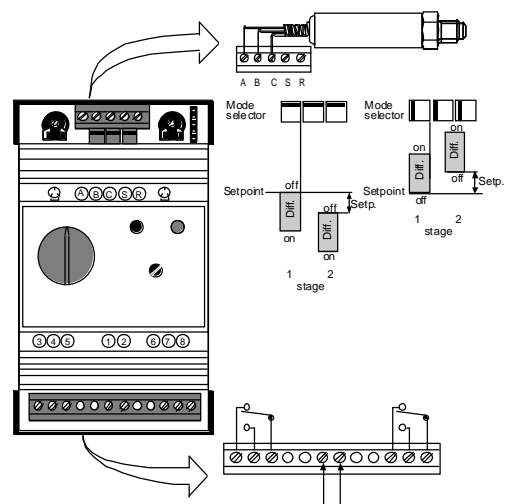

**Pressure Display module
D27P2N3**

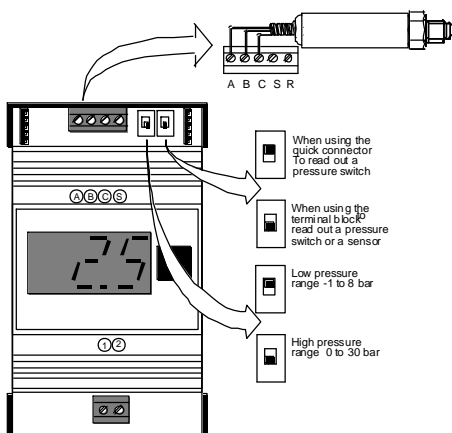

**Stage Pressure switch
S27P2**

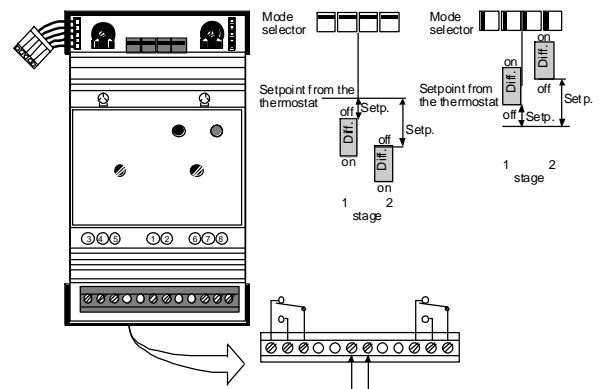

Signal Converter Module Y27M

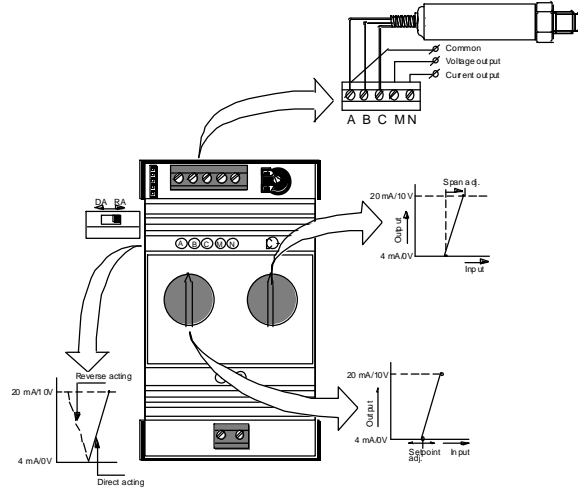

Applications

Two stage pressure control with read-out

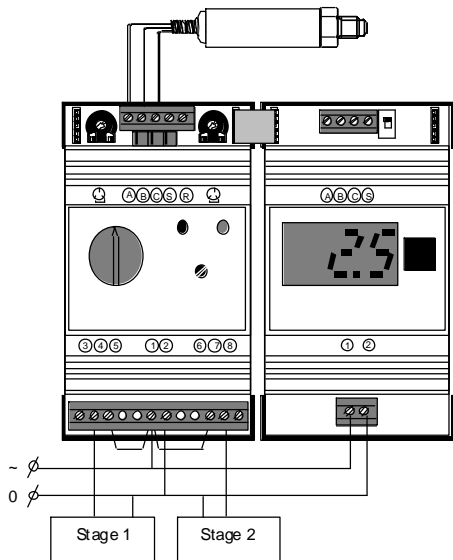

Three stage pressure control

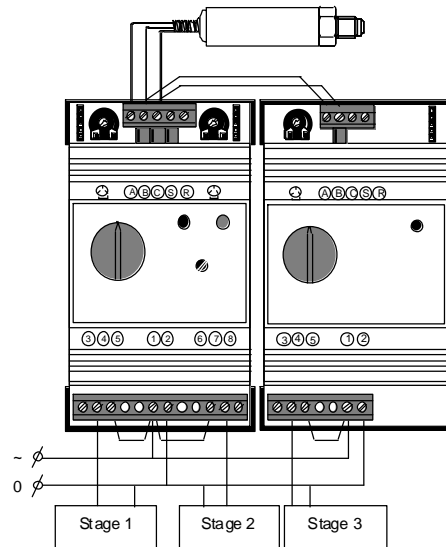

Four stage pressure control with read-out

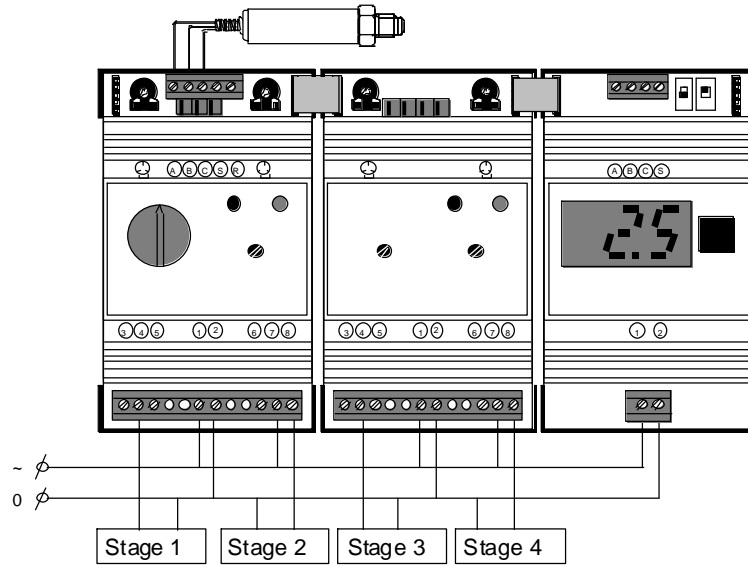

Specifications

General System 27 NOVA

Output relay rating	SPDT 10(5)A 250 V ac 10 A 30 V dc
Operating ambient temperature	-10 to +50 °C
Storage temperature	-40 to +70 °C
Operating (storage) R.H.	10 to 90 % R.H. (non condensing)
Terminals	screw type max. wire thickness 2,5 mm ²
Power supply	230 V ac ; 50/60 Hz

Additional specification for display modules

Power supply	230 V ac +10% / -15% ; 50/60 Hz
Resolution	0.1 bar
Accuracy	± 0.3 bar

Signal converter

Power supply	230 V ac +10% / -15% ; 50/60 Hz 24 V ac +10% / -15% ; 50/60 Hz
Output load	voltage output Rmin = 1 k Ω current output Rmax = 500 Ω

The performance specifications are nominal and conform to acceptable industry standards. For applications at conditions beyond these specifications, consult the local Johnson Controls office or representative. Johnson Controls shall not be liable for damages resulting from misapplication or misuse of its products.



Johnson Controls International, Inc.

Headquarters: Milwaukee, WI, USA
 European Headquarters: Westendhof 8, 45143 Essen, Germany
 European Factories: Lomagna (Italy), Leeuwarden (The Netherlands) and Essen (Germany)
 Branch Offices: Principal European Cities.

This document is subject to change

Printed in Europe

Series P28 Oil Protection Controls

Introduction

These oil protection controls are designed to give protection against low net lube oil pressure on pressure lubricated refrigeration compressors. The controls measure the pressure differential between the pressure generated by the oil pump and the refrigerant pressure at the crankcase. A built-in time delay switch allows for pressure-pick up on start and avoids nuisance shutdowns on pressure drops of short duration during the running cycle.

Description

When the compressor is started, the time delay switch is energised. If the net oil pressure does not build up within the required time limit, the time delay switch trips to stop the compressor. If the net oil pressure rises within the required time after the compressor starts, the time delay switch is automatically de-energised and the compressor continues to operate normally. If the net oil pressure should drop below setting (scale pointer) during the running cycle, the time delay switch is energised and, unless the net oil pressure returns to cut-in point within the time delay period, the compressor will be shut down, and have to be manual reset. The compressor can never run longer than the predetermined time on low oil pressure. Controls are available only for manual reset after cut-out.



P28DP Oil Protection Control
 (P) Setpoint adjusting cam

Feature and Benefits	
<input type="checkbox"/> Heavy duty pressure elements	Withstand high overrun pressure
<input type="checkbox"/> Safety lock-out with trip-free manual reset	Override is not possible in the control function
<input type="checkbox"/> Ambient compensated timing	Stable delay time during all ambient conditions
<input type="checkbox"/> Dust-tight Penn switch	Prevents pollution of the contacts by electrostatic influences

Note

These controls are designed for use only as operating controls. Where an operating control failure would result in personal injury or loss of property it is the responsibility of the installer to add devices or systems that protect against, or warn of, control failure.

Time delay switch

Timings of 30, 50, 90 or 120 seconds are available for all models. The 230 VAC time delay circuit requires 30 VA for timing of 120 seconds and 50 VA for timing of 30 seconds. The time delay unit is compensated to assure uniform timing for 0 to +55°C ambient temperature. Timing is affected only by voltage variations. After a lock-out has occurred the control can be manual reset after the time delay switch has cooled down for minimum 15 minutes.

Time delay heater circuits

Standard controls are equipped with time delay circuit for 230 VAC. Special models can be supplied at extra cost for 12 V AC/DC, 24 V AC/DC or 115/230 V AC. Quantity orders only.



Fig. 1
P28DA Control, Cover removed

Typical wiring diagrams

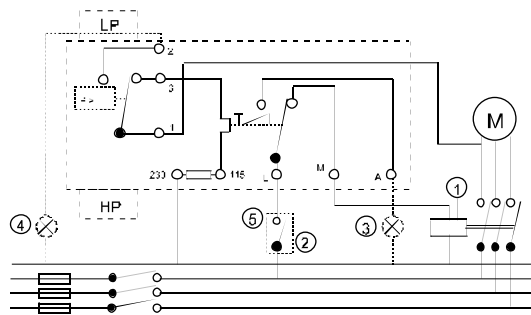

Fig. 2
P28DA

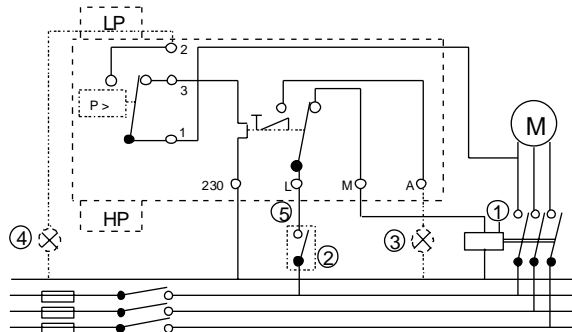

Fig. 3
P28DP/DJ

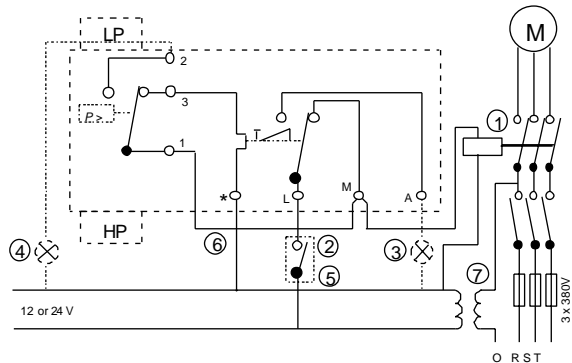

Fig. 4
12 or 24 VAC or VDC

Repair and replacement

The timer and terminal board assembly may be replaced as a complete unit. Other repairs are not recommended. When contacting the supplier for a replacement you should state the type/modelnumber of the control. This number can be found on the data plate or cover label.

- Electro-magnetic switch
- Operating control
- Alarm light
- Safe light
- Additional controls only in this line
- Jumper
- Transformer (12 or 24 V)
 "Lp" = LP bellows
 "Hp" = HP bellows

Type number selection table

Order number	Pressure connection	Timing (s)	Voltage	Refrigerant	Remarks
P28DA-9341	5	50	115/230	non-corrosive	incl.PG 13.5 nipple
P28DA-9660	13	90	115/230	non-corrosive	
P28DJ-9360	5	90	230	non-corrosive	
P28DJ-9861	15	90	230	NH3	
P28DP-9300	5	-	230	non-corrosive	without time delay
P28DP-9340	5	50	230	non-corrosive	
P28DP-9360	5	90	230	non-corrosive	
P28DP-9380	5	120	230	non-corrosive	
P28DP-9640	13	50	230	non-corrosive	
P28DP-9660	13	90	230	non-corrosive	
P28DP-9680	13	120	230	non-corrosive	
P28DP-9840	15	50	230	NH3	
P28DP-9860	15	90	230	NH3	

Pressure connections

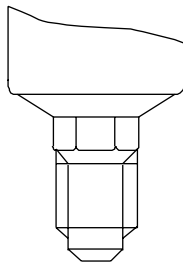

Fig. 5
Style 5
Male connection
7/16"-20 UNF for
1/4" /6 mm flare nut

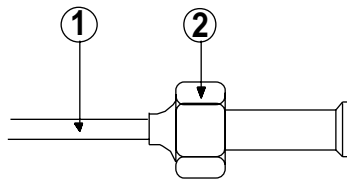

Fig. 6
Style 13
1. 90 cm capillary
2. 7/16"-20 UNF nut for
1/4" SAE flare tube

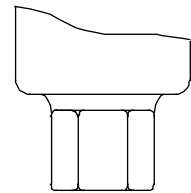

Fig. 7
Style 15
1/4"-18 NPT (female)

Accessories

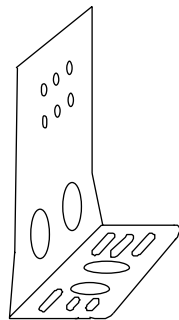

Fig. 8
Mounting Bracket
order number 271-51L

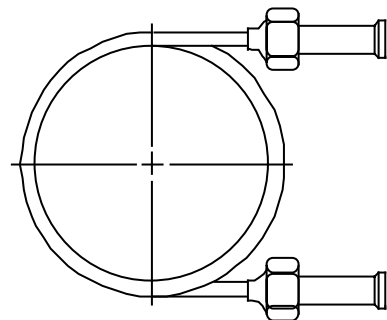

Fig. 9
90 cm Capillary with (2) flare nuts
order number SEC002N600

Accessories

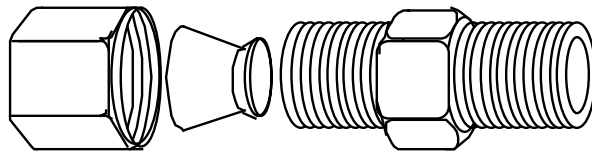
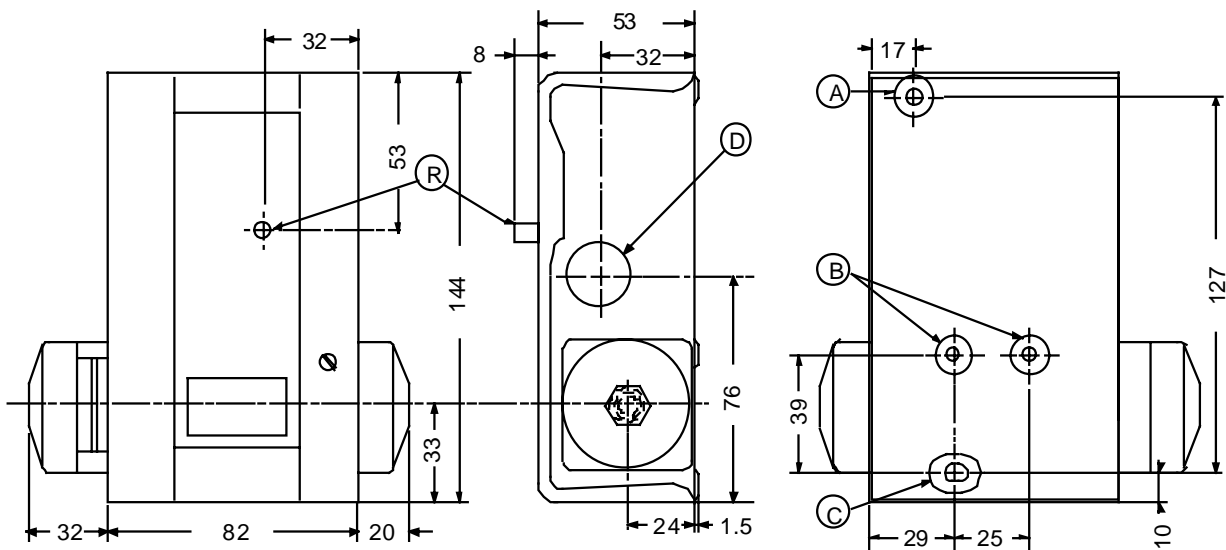

Fig. 10
Compression Coupling

Description	Application	Code number
Fits into style 15 pressure connectors	For 6 mm copper or steel tubing	CNR003N001R
	For 8 mm copper or steel tubing	CNR003N002R

Dimensions (mm)



Type P28DA/DP

- A. Mounting hole, 5 mm dia.
- B. (2) mounting bracket holes, 10-32 UNF
- C. Mounting slot
- D. Cable inlet hole, 22.3 mm dia.
- R. Reset button

Fig. 11

Dimensions (mm)

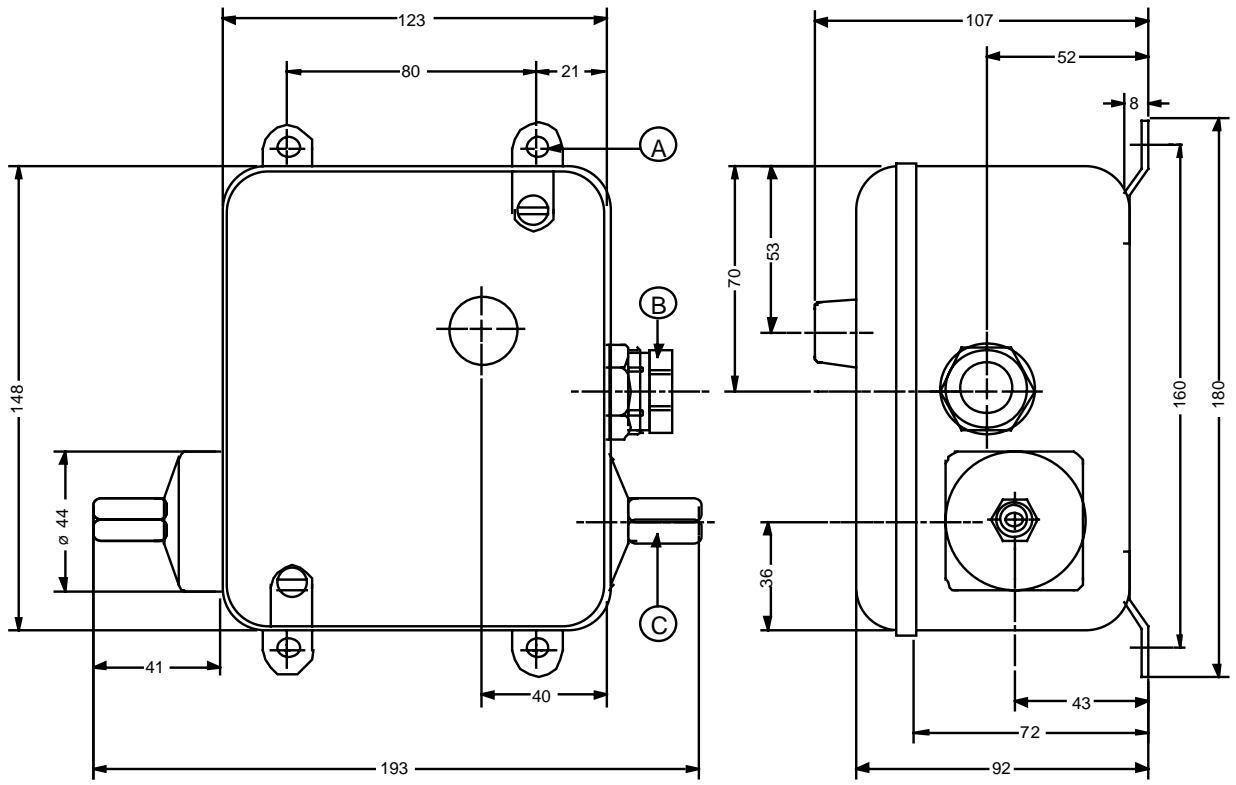

Type P28DJ

- A. (4) MTG holes, 7 mm dia.
- B. Connector, PG-16
- C. 1/4"-18 NPT (2x)

Fig. 12

Notes

Notes

Specifications

Product series	P28DJ/DP	single voltage	230 V
	P28DA	dual voltage	115/230 V
Application	Oil protection control on refrigeration compressors		
Pressure connectors	Style 5, 15, 13 (see drawings)		
Operating range*	0.6 to 4.8 bar Operating at pressures greater than 17 bar may lead to bellows failure and catastrophic refrigerant loss		
Maximum allowable overrun pressure	23 bar		
Range adjustment	Turn range cam to reach set point desired		
Material	Case 1.5 mm cold-rolled steel, zinc plated Cover 0.8 mm cold-rolled steel, blue enamel finish		
Enclosure	Type P28DA/DP	IP30	
	Type P28DJ	IP66	
Electrical ratings	15(8) A, 230 Vac		
Shipping weight	P28DA/DP	Individual pack	1.5 kg
		Overpack (10 pcs)	15 kg
	P28DJ	Individual pack	3 kg
		Overpack (4 pcs)	12 kg
Accessories	Mounting bracket	order number	271-51L
(order separately)	Compression coupling	(6mm) order number	CNR003N001R
		(8mm)	CNR003N002R
	90 cm capillary with two flare nuts	order number	SEC002N600

* Time delay de-energised at 0.21 to 0.34 bar pressure difference above setting
100 kPa = 0.1 MPa = 1 bar ≈ 1.02 kp/cm² = 1.02 at ≈ 14.5 psi

The performance specifications are nominal and conform to acceptable industry standards. For applications at conditions beyond these specifications, consult the local Johnson Controls office or representative. Johnson Controls shall not be liable for damages resulting from misapplication or misuse of its products.

JOHNSON
CONTROLS

Johnson Controls International, Inc.

Headquarters: Milwaukee, WI, USA
European Headquarters: Westendhof 8, 45143 Essen, Germany
European Factories: Lomagna (Italy), Leeuwarden (The Netherlands) and Essen (Germany)
Branch Offices: Principal European Cities.
This document is subject to change

Printed in Europe

Series P45

Lube-oil Protection Controls With Built-in Time Delay Switch

Introuction

The series P45 controls are designed to give protection against low lube-oil pressure on pressure lubricated refrigeration compressors. The controls measure the pressure differential (net oil pressure) between the pressure generated by the oil pump and the refrigerant pressure at the crankcase. A built-in time delay switch allows pressure build-up during start and avoids nuisance shut-down on pressure drops of short duration during the running cycle.



P45 Style 5



P45 Style 13

Feature and Benefits

<input type="checkbox"/> Several million in use today.	Proven to be a reliable product.
<input type="checkbox"/> Heavy duty pressure elements.	Long-life control. Withstands higher overrun pressure of 29 bar.
<input type="checkbox"/> Key specifications match/exceed other brands.	Easily replaces existing lube-oil controls.
<input type="checkbox"/> Accurate 0.2 bar switch differential standard.	Covers more applications.
<input type="checkbox"/> Adjustable or fixed setpoint.	One model can be used on several applications.
<input type="checkbox"/> Safelight output standard.	More customer flexibility.
<input type="checkbox"/> Trip-free manual reset.	Better compressor protection.
<input type="checkbox"/> High current rated output.	Can be used in more applications.
<input type="checkbox"/> Ambient compensated timing.	Stable delay time.

Description

The P45 series is a differential pressure switch which senses the oil pressure and the suction pressure on compressors using non corrosive refrigerant.

When the compressor is started, the time delay switch is energised. If the net oil pressure does not build up to the "heater-off" point of the control within the required time limit, the time delay switch trips to stop the compressor. If the net oil pressure rises to the "heater-off" point within the required time after the compressor starts, the time delay switch is automatically de-energised and the compressor continues to operate normally. If the net oil pressure should drop below the "heater-on" setting during the running cycle, the time delay switch is energised and, unless the net oil pressure returns to heater "off" point within the time delay period, the compressor will be shut down. The compressor can never run more than the predetermined time on subnormal oil pressure.

Function

- A. During start-up the lube-oil pressure is built up to the control setpoint plus the mechanical differential, before elapse of the delay period ②. Then the time delay heater is de-energised. i.e. normal oil conditions have been established.
- B. During start-up the lube-oil pressure does not build up a pressure to the setpoint plus mechanical switch differential level before the end of the delay period ②. The compressor will stop. Terminal A, when connected to a signal will be activated.
- C. During running period the lube-oil pressure falls to a value lower than the setpoint (cut-out). The timer will be activated.
- D. The lube-oil pressure reaches the setpoint plus mechanical switch differential value before the delay period ② elapses. The heater will be de-energised. The compressor lube-oil conditions are normal again.
- E. The lube-oil pressure falls to a lower value than the setpoint (cut-out). The timer will be activated.

- F. The lube-oil pressure remains at a lower value than the setpoint plus the mechanical differential during the delay period ②. The compressor will stop. Terminal A, when connected to a signal will be activated. Restart can only be performed after about 5 min. by means of pushing the reset button, provided the cause of the fault has been determined.

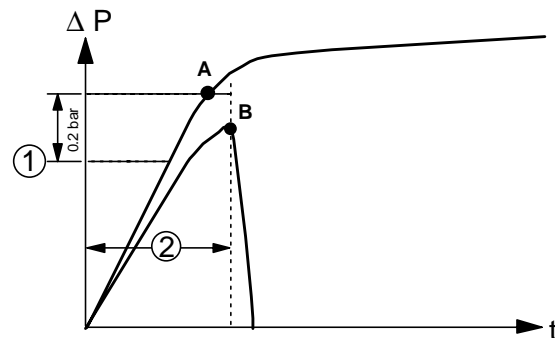

Fig. 1a
During start up

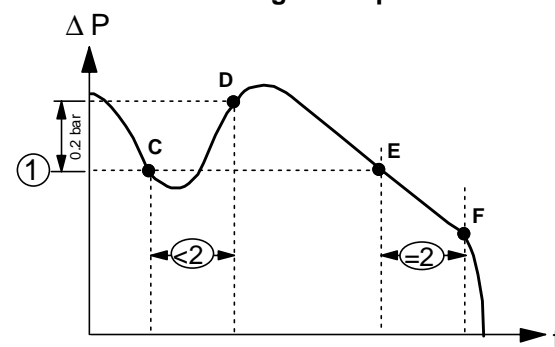

Fig. 1b
During operation

- ① Setpoint in bar (factory set see data label)
② Time delay in s. (see data label)

System Check

It is important that the function check be made to insure that the differential pressure control is operating correctly. This check can be made by pressing the lever on the right side of the control for a period corresponding to the delay time. When the test is correctly executed the compressor stops after the delay time determined by the time delay has elapsed.

Note

These controls are designed for use only as operating controls. Where an operating control failure would result in personal injury or loss of property it is the responsibility of the installer to add devices or systems that protect against, or warn of, control failure.

Time delay switch

The time delay switch is a trip-free, expansion rod device actuated by a resistance heater which is wired as an integral part of the control. Models are available for 50, 90 or 120 seconds.

Optional construction note (For quantities only)

Time delay switches.

- For 12 V and 24 V ac/dc and 120 Vac are available on request.
- 30, 45 or 60 sec. time delay.

Pressure connections.

- Controls with 90 cm capillary with 1/4" braze connection (style 34) may be supplied on quantity orders, when specified.

Various.

- PG nipple
- Field adjustable setpoint
- Bulk pack
- Mounting bracket

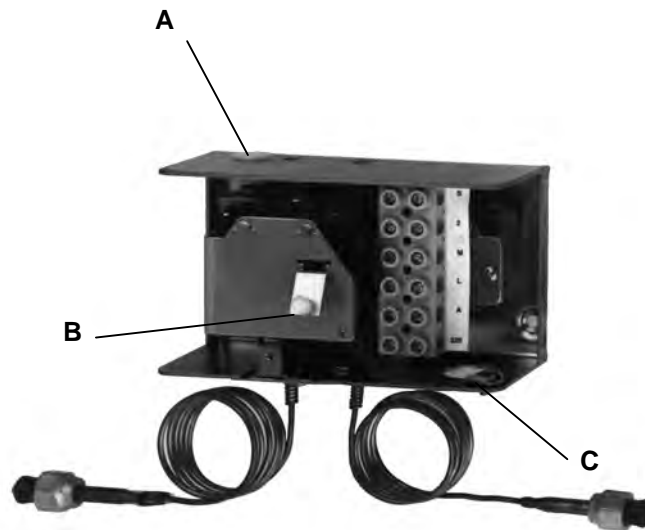

Fig. 2
P45 interior.

- A. Cap for sealed adjustment (factory set)
- B. Reset button
- C. Conduit opening: 22.3 mm hole for PG16 nipple or conduit connector

Adjustment

The P45 is normally factory set and is available with optional field adjustment. However the factory set models can be adjusted by using adjusting wrench WRN12-1. Field adjustable models can be set with a screwdriver. As the P45 has no scale, the setpoint must be checked by using manometers.

Repair and replacement

Repair is not possible. In case of an improperly functioning control, please check with your nearest supplier. When contacting the supplier for a replacement you should state the type/model number of the control. This number can be found on the data plate or cover label.

Type number selection table

Order number	Delay time (s)	Pressure connection	Voltage V ac
P45NCA-9056	50	13	230/115
P45NCA-9104	120	13	230/115
P45NCA-9641	50	13	230/115
P45NBB-9341	50	5	230
P45NBB-9640	50	13	230
P45NBB-9361	90	5	230
P45NBB-9660	90	13	230
P45NBB-9381	120	5	230
P45NBB-9680	120	13	230

Note: If your requirements are not in the type number selection table, then please contact your Johnson Controls representative.

Setting specification

Setting (bar)	Suffix	Setting (bar)	Suffix	Setting (bar)	Suffix
0.5	A	1.0	F	1.5	M
0.6	B	1.1	G	1.6	N
0.7	C	1.2	H	1.7	P
0.8	D	1.3	K	1.8	Q
0.9	E	1.4	L	1.9	R
				2.0	S

When ordering, the corresponding suffix for the required setpoint must be indicated after the model number. For example: P45NBB-9660M is a P45 set at 1.5 bar.

Typical wiring diagrams

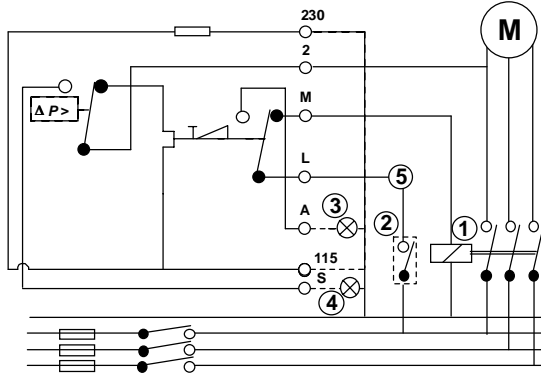

Fig.3
P45NCA

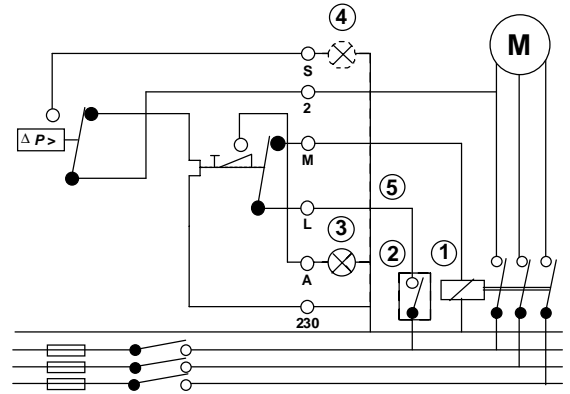

Fig. 4
P45NBB

1. Magnetic starter relay
2. Operating control
3. Alarm light
4. Safe light
5. Additional controls only in this line

Pressure connections

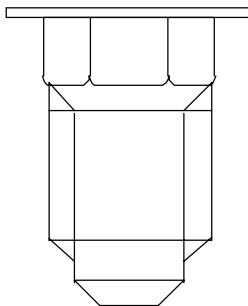

Fig. 5
Style 5
1. 7/16-20 UNF male for
1/4" SAE flare tube

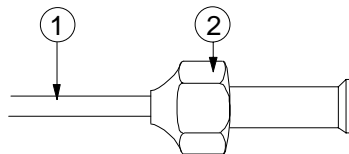

Fig. 6
Style 13
1. 90 cm capillary
2. 7/16-20 UNF nut for 1/4"
SAE flare tube

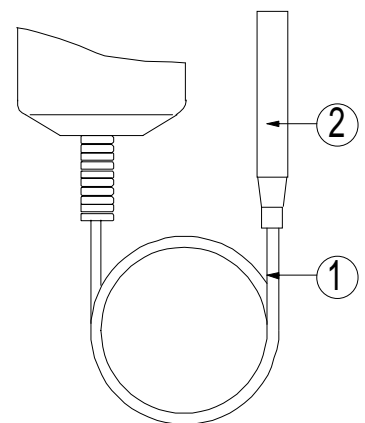
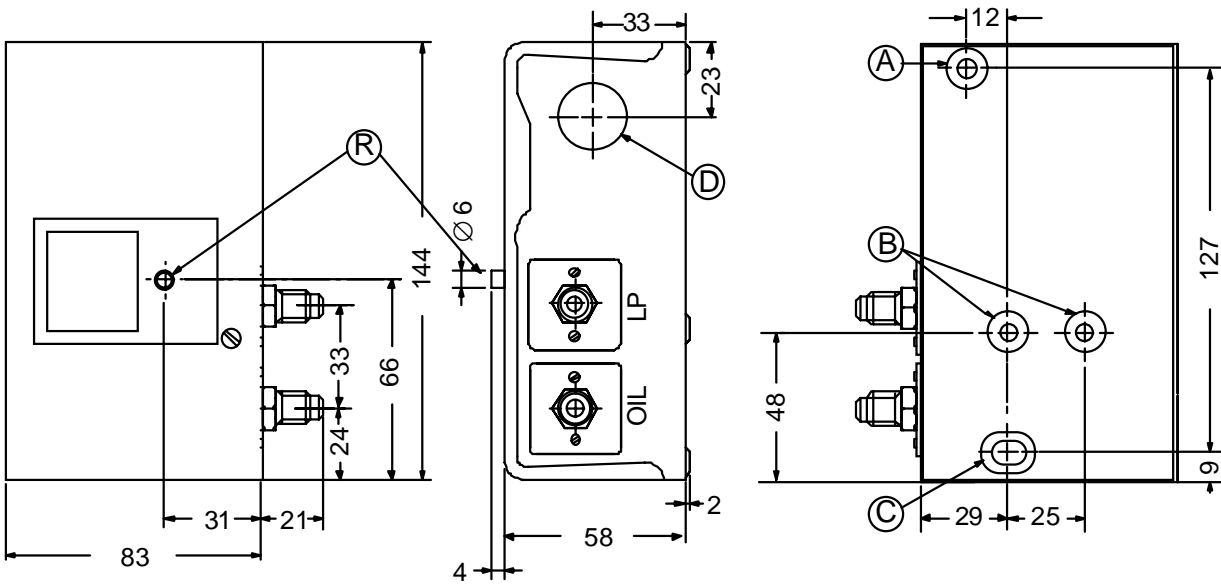
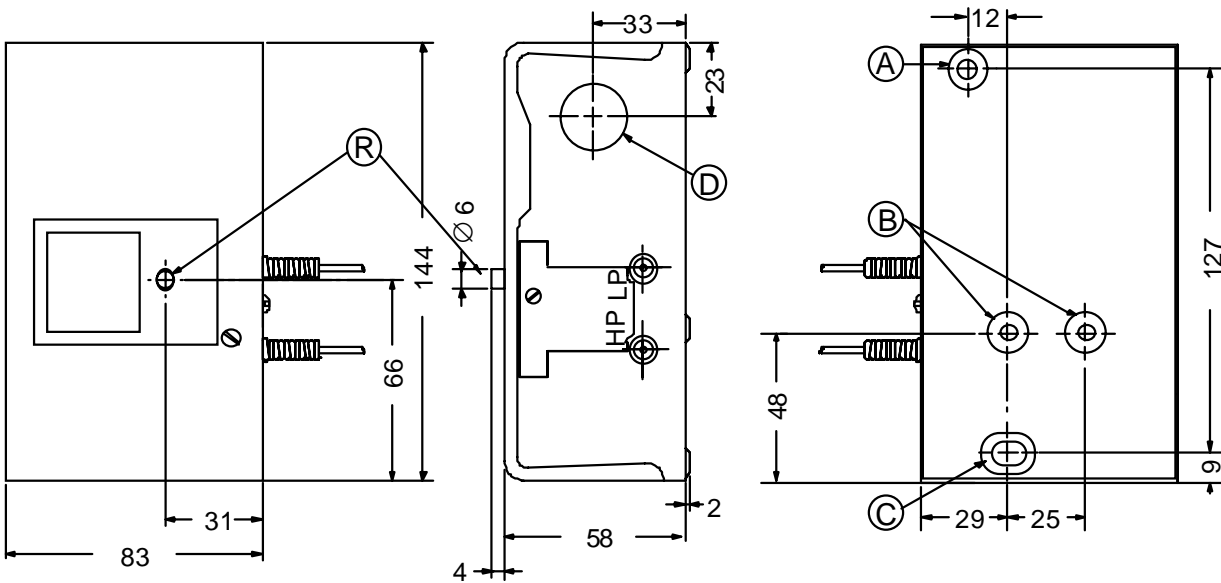

Fig. 7
Style 34 (Optional)
1. 90 cm capillary
2. 1/4" ODM Braze
connection

Dimensions (mm)



Style 5
Fig. 8



Style 13

- A. Mounting hole, 5 mm dia.
- B. (2) Mounting holes, threaded 10 - 32 UNF
- C. Mounting slot, 9.5 x 5 mm
- D. Conduit hole, 22.3 mm dia., for PG-16 nipple
- R. Reset button

Fig. 9

Notes

Optional accessories

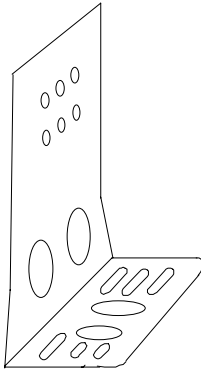

Fig. 10
Mounting bracket
Order number **271-51**

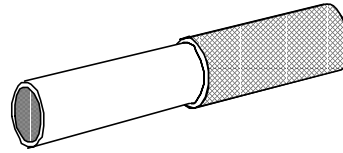

Fig. 11
Adjusting wrench
Order number **WRN12-1**

Specifications

Type number	See type number selection table	
Refrigerant	Non-corrosive, all range	
Alarm contact	Yes	
Safe light contact	Yes	
Operating range	0.5 to 4 bar	
Ambient temperature	-40 to +60 °C	
Maximum allowable overrun pressure	29 bar	
Material	case	1.5 mm cold-rolled steel, zinc plated
	cover	0.8 mm cold-rolled steel, painted
Enclosure	IP 30	
Electrical rating pilot circuit	~15(8)A 230 V	
Shipping weight	ind. pack	1.5 kg
	overpack	16 kg (10 pieces)
Accessories	Mounting bracket	order number 271-51
(order separately)	Adj. wrench	order number WRN12-1
Dimensions	(see Dimension drawing)	

Time delay heater de-energised at 0.2 bar pressure difference above setting.

Note: 1 bar = 100 kPa ≈ 14.5 psi.

The performance specifications are nominal and conform to acceptable industry standards. For applications at conditions beyond these specifications, consult the local Johnson Controls office or representative. Johnson Controls shall not be liable for damages resulting from misapplication or misuse of its products.

**JOHNSON
CONTROLS**

Johnson Controls International, Inc.

Headquarters: Milwaukee, WI, USA
 European Headquarters: Westendhof 8, 45143 Essen, Germany
 European Factories: Lomagna (Italy), Leeuwarden (The Netherlands) and Essen (Germany)
 Branch Offices: Principal European Cities.

This document is subject to change

Printed in Europe

Series P48

Pressure Controls for Steam, Air or (hot) Water

Introduction

The series P48 pressure controls are designed as operating or high/low cut-out control on steam, air or (hot) water applications. Also for non-combustible gases which are not harmful to the materials in contact with these mediums. On steam applications a steam trap is recommended (see Accessories). Some models have been tested and approved according to PED97/23EC Cat IV (see type number selection table)

Description

The P48 series have been developed for special applications where pressure must be controlled. All models have an adjustable differential depending on the range (see type number selection table). The P48AAA-9110 and P48AAA-9120 has the power element outside the case. All the models have phosphor bronze bellows and brass pressure connections except the P48AAA-9150. This model has a stainless steel bellows and pressure connection and is provided with a brass adapter 1/4"-18 NPT female to R3/8 male.



P48 Pressure Control for Steam, Air or (hot) Water

Feature and Benefits	
<input type="checkbox"/> Generous wiring space provided	Easy wiring and maintenance
<input type="checkbox"/> Splash-proof enclosure (IP54)	Can be used for indoor/outdoor applications
<input type="checkbox"/> SPDT contacts are provided as standard on single pressure control	Can be wired for alarm functions
<input type="checkbox"/> Trip-free manual reset	Override is not possible in the control function.

Note

These controls are designed for use only as operating controls. Where an operating control failure would result in personal injury or loss of property it is the responsibility of the installer to add devices or systems that protect against, or warn of, control failure.

Manual reset models are possible as optional construction for quantities only.

Mounting

Mounting can easily be done with a mounting bracket 271-51L (order separately) or directly on a surface. Mounting holes 4.5 mm diam. and M4 holes are provided.

Adjustment

Adjustment of range and differential can be done by turning the hexagonal range screw and differential screw. These screws can also be locked by a lockplate accessory (KIT023N600) (order separately).

The range scale indicates high switch point (contacts A - B open, A - C closed). Deduct differential to obtain low switch point.

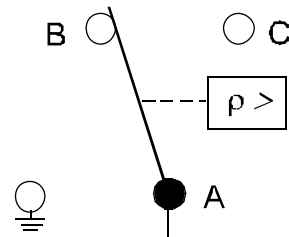
Contact function**Fig. 1**

**A - B open on pressure increase.
A - C close simultaneously.**

Optional construction note

If your requirements are not in the type number selection table, then please contact your Johnson Controls representative.

Repair and replacement

Repair is not possible. In case of an improperly functioning control, please check with your nearest supplier. When contacting the supplier for a replacement you should state the type/model number of the control. This number can be found on the data plate or cover label.

Type number selection table

Range (bar)	Differential (bar)	Max. bellows pressure (bar)	Approved acc. To PED 97/23EC Cat IV	Order number
0 - 1	0.16 - 0.55	3.5	Yes	P48AAA-9110
0.2 - 4	0.25 - 0.80	8	Yes	P48AAA-9120
-0.2 - 10	1 - 4.5	15	Yes	P48AAA-9130
1 - 16	1.3 - 2.5	25	Yes	P48AAA-9140
3 - 30	3 - 12	33	No	P48AAA-9150
0.2 - 4	Manual reset	8	Yes	P48BEA-9120
4 - 16		25	Yes	P48BEA-9140

Note: 1 bar = 100 kPa ≈ 14.5 psi

Accessories (order separately)

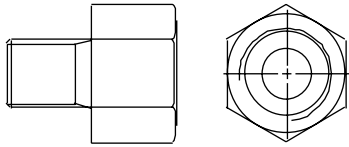

Fig. 2
Brass adapter R3/8 female
to 1/4-18 NPT male
order number
CNR012N001R

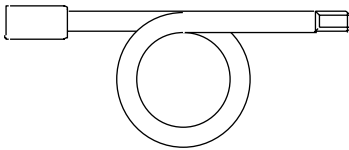

Fig.3
Steam trap 1/4-18 NPT
male/female
order number TBG16A-600

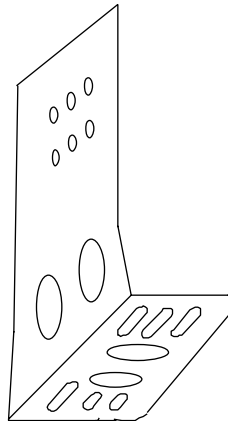

Fig. 4
Mounting bracket
order number 271-51L

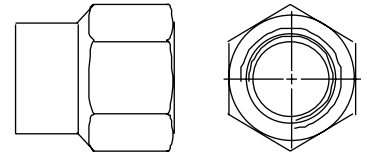

Fig. 5
Brass adapter R3/8 female
to 1/4-18 NPT female
order number
CNR013N001R

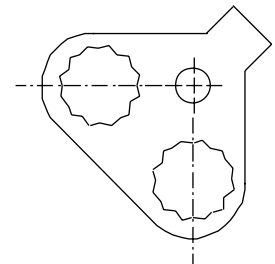

Fig. 6
Locking kit
order number KIT023N600
(incl. with PED appr. models)

Power element dimensions (mm)

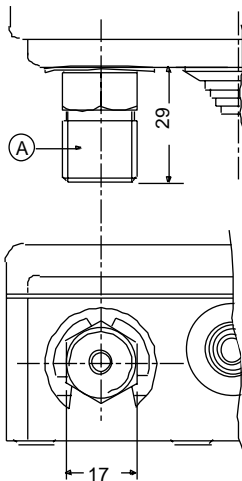

Fig. 7
All ranges except 0 to 1 bar and 0.2 to 4 bar
A. R3/8

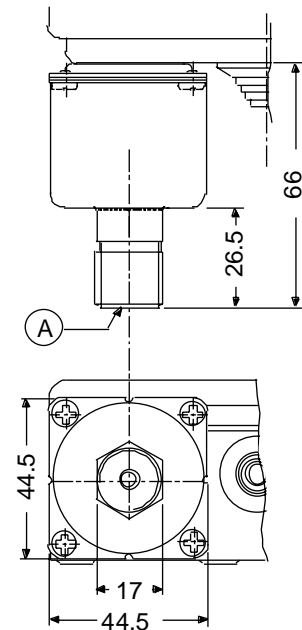
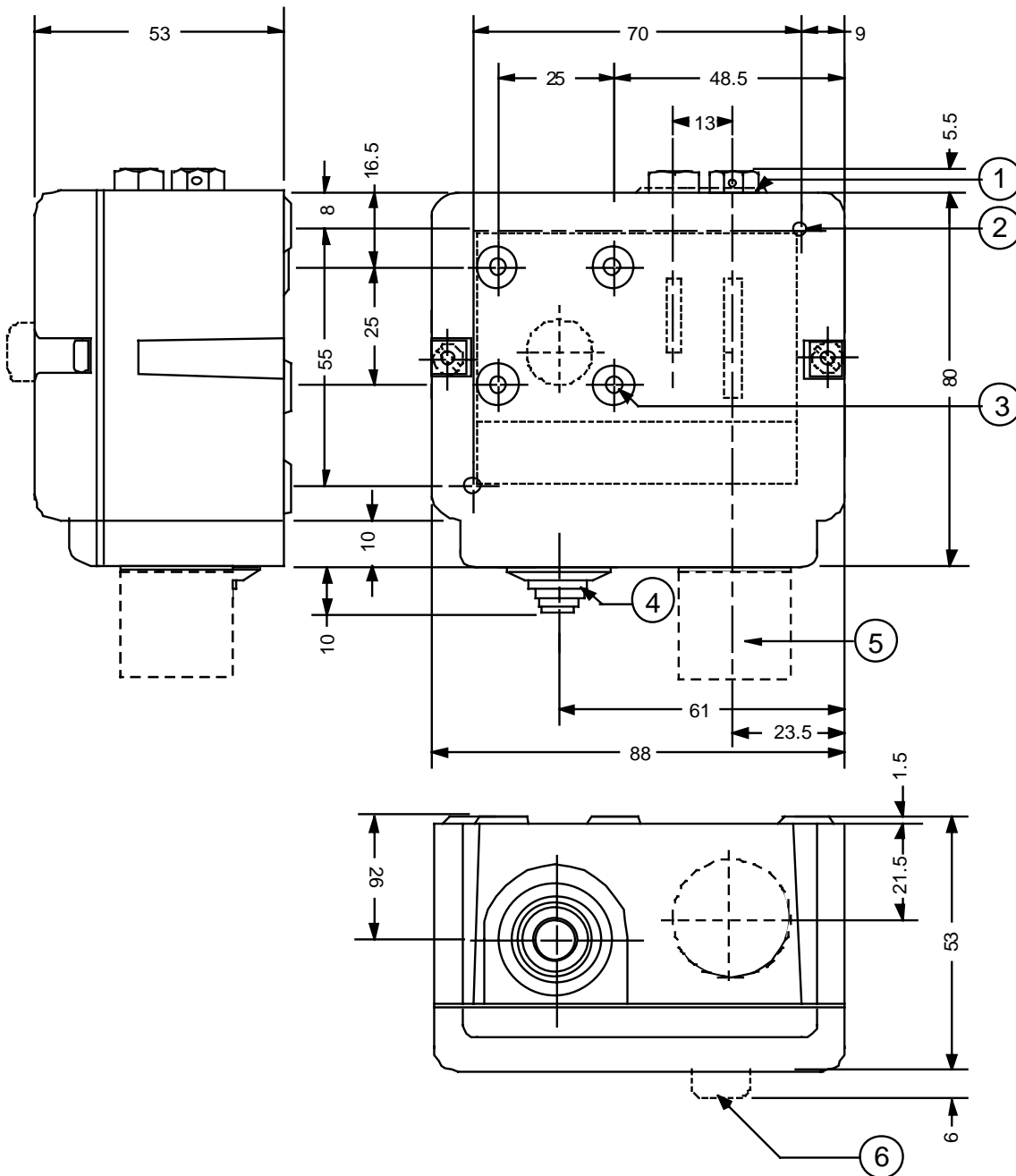

Fig. 8
Ranges 0 to 1 bar and 0.2 to 4 bar
A. R3/8

Dimensions (mm)



1. Lockplate (if applied)
2. Two mounting holes $\varnothing 4.5$
3. Four mounting holes M4 (deep 6 mm)
4. Cable inlet grommet (cable range $\varnothing 5$ to $\varnothing 13$)
5. Power element see fig 1 and 2
6. Reset button (reset models only)

Fig. 9

Specifications

Types, ranges differentials	See type number selection table	
Media	Steam, air, water, non-combustible gases	
Max. medium temperature	+80 °C	
Pressure connector	R 3/8 male*	
Ambient temperature limits	-50 to + 55 °C (+70 °C maximum duration two hours)	
Material	case and cover	Weather-proof aluminium die cast
	contact unit	Large copper backed silver cadmium (AgCdO) contacts on phosphor bronze conductor leaves
	bellows	Phosphor bronze**
Protection	IP54	
Electrical rating	~16(10)A 400 V ∴ 220 V, 12 W (pilot duty only)	
Packaging	Individual package	
Shipping weights	ind. pack	0.5 kg
	overpack	P48AAA-9110 24 pcs. (12 kg)
		P48AAA-9120
		P48BEA-9120
		P48AAA-9150 36 pcs (20 kg)
		P48AAA-9130
		P48AAA-9140
		P48BEA-9140
		P48AAA-9230

* Except P48AAA-9150: 1/4"-18 NPT plus adapter to R3/8 male and P48AAA-9230 which is G1/4" female.

** Except P48AAA-9150: stainless steel 316 L.

The performance specifications are nominal and conform to acceptable industry standards. For applications at conditions beyond these specifications, consult the local Johnson Controls office or representative. Johnson Controls shall not be liable for damages resulting from misapplication or misuse of its products.

**JOHNSON
CONTROLS**

Johnson Controls International, Inc.

Headquarters: Milwaukee, WI, USA

European Headquarters: Brussels, Belgium

European Factories: Lomagna (Italy), Leeuwarden (The Netherlands) and Essen (Germany)

Branch Offices: Principal European Cities.

This document is subject to change

www.johnsoncontrols.com
Printed in Europe

Series P74

Differential Pressure Controls, without time delay

Introduction

These controls are designed to sense pressure differences between two points and may be used as operating or limit controls. Typical applications are to detect flow across a chiller or water cooled condenser, to detect flow in a heating system and sensing lube oil pressure differential on refrigeration compressors.

Description

The P74 series of differential pressure switches incorporate two opposing pressure elements and an adjustable range setpoint spring with a calibrated scale. The control switches at the indicated setpoint on an increase in differential pressure and switches back to the normal position when the different pressure decreases to the setpoint less the mechanical switching differential.

Note

These controls are designed for use only as operating controls. Where an operating control failure would result in personal injury or loss of property it is the responsibility of the installer to add devices or systems that protect against, or warn of, control failure.



P74 Differential Pressure Control

Adjustment

The setpoint can be adjusted by the notched cam **A** (see photo) located on the top of the control. The switching differential can be adjusted by turning a hexagonal nut on the differential adjusting screw located inside the control cover (adjustable differential models only).

Feature and Benefits

- | | |
|--|------------------------------------|
| <input type="checkbox"/> Heavy duty pressure elements. | Withstands high overrun pressures. |
| <input type="checkbox"/> These controls may be used in combination with series P28 lube oil protection control on two compressor, single motor units. | Reduces the lube oil system cost. |

Contact function

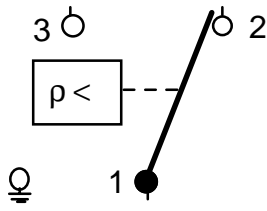

Fig. 1a
Type P74EA and P74FA

1 - 2 closes on increase of differential pressure.
1 - 3 opens simultaneously.

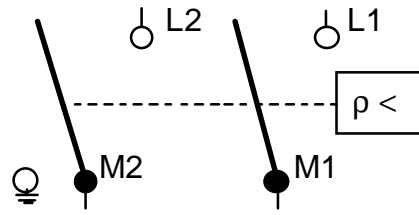

Fig. 1b
Type P74DA

Contacts close on increase of differential pressure.

Repair and replacement

Power elements may be replaced in the field. Other repairs are not possible. In case of an improperly functioning control, please check with your nearest supplier.

When contacting the supplier for a replacement you should state the type/model number of the control. This number can be found on the data plate or cover label.

Pressure connections

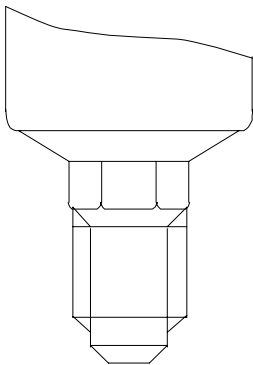

Fig.2
Style 5

1. $\frac{7}{16}$ "-20 UNF male for $\frac{1}{4}$ " SAE flare tube

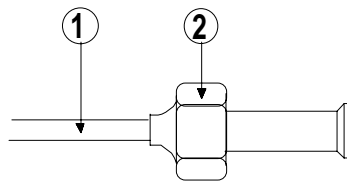

Fig.3
Style 13

1. 90 cm capillary
2. $\frac{7}{16}$ "-20 UNF nut for $\frac{1}{4}$ " SAE flare tube

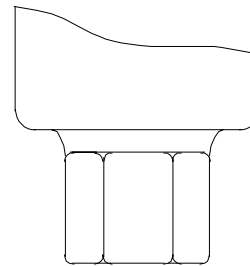

Fig.4
Style 15

$\frac{1}{4}$ "-18 NPT female

Type number selection table

Order number	P74DA-9300	P74DA-9600	P74EA-9300	P74EA-9600
Range ΔP (bar)	0.6/4.8	0.6/4.8	0.6/4.8	0.6/4.8
Switching differential (bar)	0.7/2 adj.	0.7/2 adj.	0.3 fix.	0.3 fix.
Medium	Non-corrosive Refrigerant	Non-corrosive Refrigerant	Non-corrosive Refrigerant	Non-corrosive Refrigerant
Pressure connector (style)	5	13	5	13
Electrical rating	15(10) A 230 V ac	15(10) A 230 V ac	15(8) A 230 V ac	15(8) A 230 V ac
Contact function	fig. 1b	fig. 1b	fig. 1a	fig. 1a
Maximum bellows pressure absolute (bar)	23	23	23	23
Maximum allowable diff. in pressure between the bellows (bar)	14	14	14	14
Pressure element material	stainless steel/copper	stainless steel/copper	stainless steel/copper	stainless steel/copper

Order number	P74EA-9700	P74FA-9700	P74FA-9701	
Range ΔP (bar)	0.6/4.8	0/1	2.0/8.0	
Switching differential (bar)	0.3 fix.	0.1 fix.	0.7 fix.	
Medium	Ammonia or Non-corrosive Refrigerant	Water	Ammonia or Non-corrosive Refrigerant	
Pressure connector (style)	15	15	15	
Electrical rating	15(8) A 230 V ac	15(3) A 230 V ac	15(3) A 230 V ac	
Contact function	fig. 1a	fig. 1a	fig. 1a	
Maximum bellows pressure absolute (bar)	23	10	23	
Maximum allowable diff. in pressure between the bellows (bar)	14	7	14	
Pressure element material	stainless steel	tombac/ brass	stainless steel	

Note: 1 bar = 100 kPa \approx 14.5 psi

Dimensions (mm)

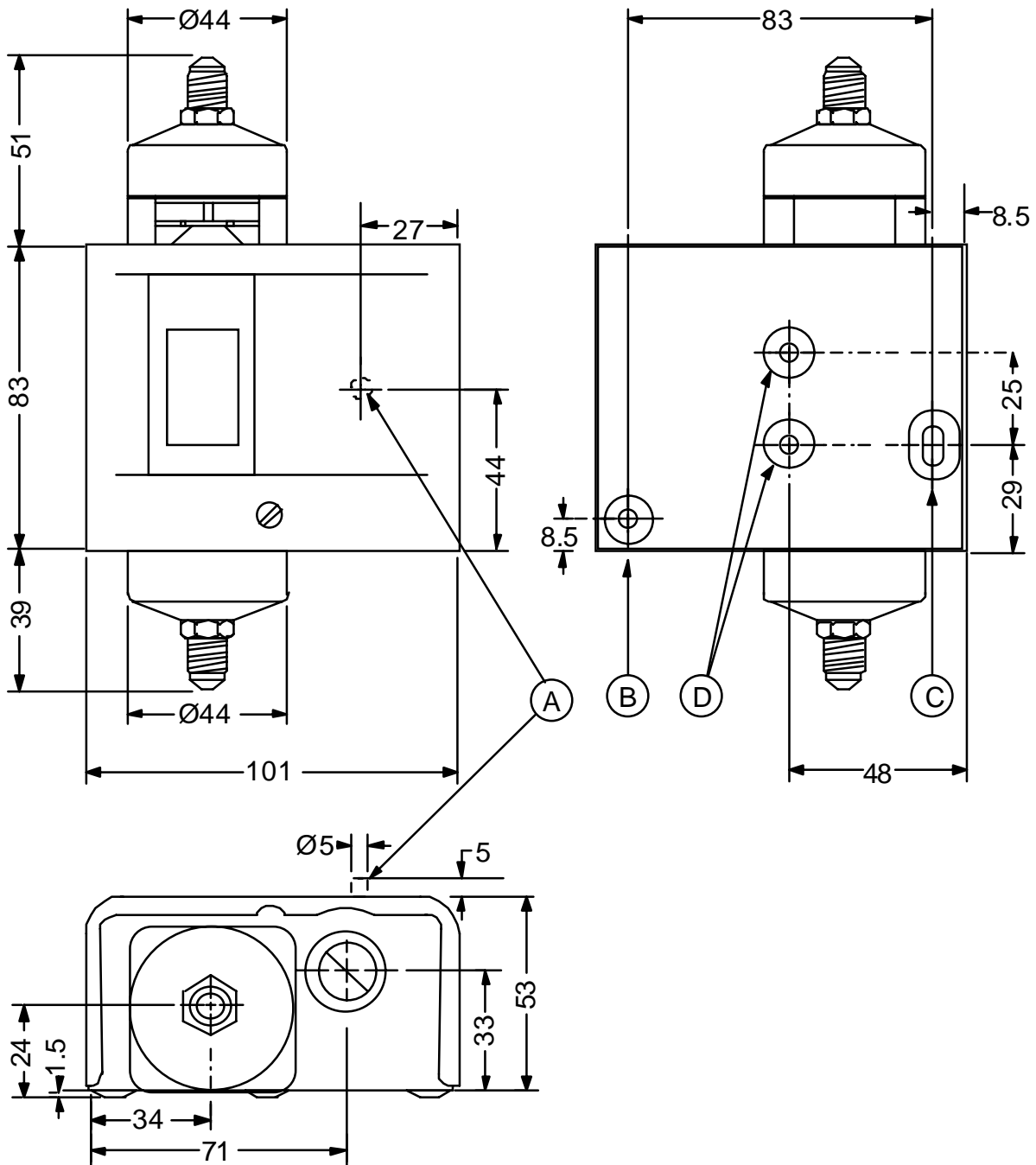

Fig. 5

- A = Reset button
- B = Mounting hole, $\text{Ø} 5$ mm
- C = Mounting slot
- D = 10 - 32 UNF2B

Accessories (optional)

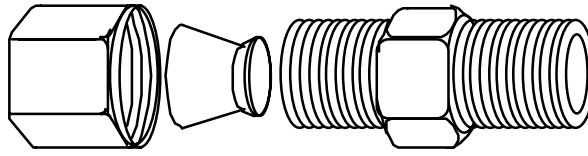

Fig. 6
Compression Coupling

Description	Application	Order number
Fits into style 15 pressure connectors	For 6 mm copper or steel tubing	CNR003N001R
	For 8 mm copper or steel tubing	CNR003N002R

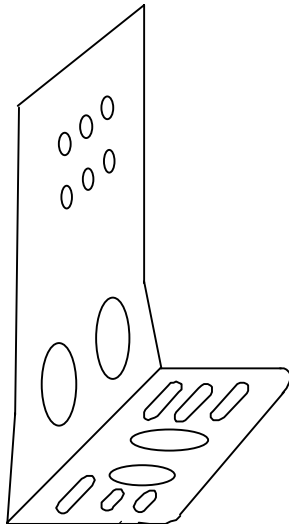

Fig. 7
Mounting bracket
Order number **271-51L**

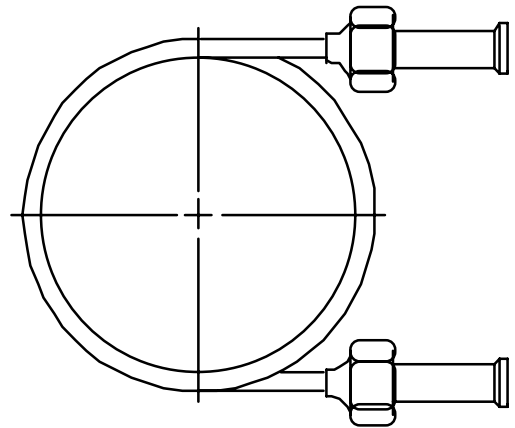

Fig. 8
90 cm Capillary with (2) flare nuts (1/4" SAE)
Order number **SEC002N600**

Notes

Notes

Specifications

Types, ranges differentials	See type number selection table	
Media	Ammonia (for special models), non-corrosive refrigerant or water	
Pressure connections	See type number selection	
Maximum overrun pressure	See type number selection	
Ambient temperature limits	-30/+55 °C	
Material	case	Cold-rolled steel, zinc plated
	cover	Cold-rolled steel, painted
	pressure element	See type number selection
Protection	IP30	
Electrical rating	See type number selection	
Shipping weights	ind. pack	1.2 kg
	overpack	12 kg (10 pcs.)
Accessories (order separately)	Mounting bracket, Compression coupling, 90 cm capillary with two flare nuts. (For code numbers see page 5.)	
Dimensions	See dimension drawing.	

The performance specifications are nominal and conform to acceptable industry standards. For applications at conditions beyond these specifications, consult the local Johnson Controls office or representative. Johnson Controls shall not be liable for damages resulting from misapplication or misuse of its products.

JOHNSON
CONTROLS

Johnson Controls International, Inc.

Headquarters: Milwaukee, WI, USA
 European Headquarters: Westendhof 8, 45143 Essen, Germany
 European Factories: Lomagna (Italy), Leeuwarden (The Netherlands) and Essen (Germany)
 Branch Offices: Principal European Cities.

This document is subject to change

Printed in Europe

Series P77

Single Pressure Controls for Refrigeration, Air-conditioning and Heatpump Applications

Introduction

These pressure controls are designed for use in a variety of applications involving refrigeration high or low pressure. Models supplied have a "whole range" design, enabling them to be used with refrigerants R22, R134A, R404A and all other non-corrosive refrigerants which are within the operating range of the control. They may also be used for other high or low pressure applications such as air, water etc. Models which can be used with ammonia as well as controls tested, conforming to DIN 32733, and approved by TÜV are included in the program. DIN (HP) models are also tested and approved according to PED 97/23EC Cat. IV.



**P77 Single Pressure Control
for Refrigeration**

Description

The P77 series pressure controls may be used for control functions or limit functions, depending on model number. All models are provided with alarm contacts. All standard models have phosphor bronze bellows and brass pressure connections. Models for use with ammonia are provided with stainless steel bellows and connectors. Devices conforming to DIN 32733 have a double bellows on the high pressure versions. Their IP54 classification means that these pressure controls are suitable for almost all applications.

Feature and Benefits	
<input type="checkbox"/> Generous wiring space	Easy wiring and maintenance
<input type="checkbox"/> Splash-proof enclosure (IP54)	Can be used for indoor/outdoor applications
<input type="checkbox"/> SPDT contacts are provided as standard on single pressure controls.	Can be wired for alarm functions
<input type="checkbox"/> Trip-free manual reset	Override is not possible in the control function

Note

The controls are intended to control equipment under normal operating conditions. Where failure or malfunctioning of the controls could lead to an abnormal operating condition that could cause personal injury or damage to the equipment or other property, other devices (limit or safety controls) or systems (alarm or supervisory systems) intended to warn of or protect against failure or malfunctioning of the controls must be incorporated into and maintained as part of the control system.

Note

To facilitate order handling special ordering codes have been added to some commonly used models

Type number matrix

P77AAA	Automatic reset
P77BCA	Open low - manual reset
P77BEA	Open high - manual reset
P77AAW	HP or LP Limit (Auto. Reset) conforming to DIN 32733
	HP conforming to PED 97/23CE
P77BEB	HP Limit (Man. Reset) conforming to DIN 32733, PED 97/23CE
P77BES	HP Safety Limit (Man. Reset) conforming to DIN 32733, PED 97/23CE
P77BCB	LP Limit (manual reset) conforming to DIN 32733

Mounting

Mounting can easily be done with mounting bracket 271-51L (order separately) or directly on a surface. Mounting holes 4,5 mm diam. and M4 holes are provided.

Adjustment

Adjustment of range and differential can be done by turning the hexagonal range screw and differential screw. Manual reset models have a range screw only. The adjustment screw can also be locked by a lock plate accessory (KIT023N600). The lock plate is only included with those devices which are conform to DIN 32733.

On all models the scale indicates the high switch point (Except type P77BCA, P77BCB, here the scale indicates the low (cut-out) switch point). The low switch point can be derived by deducting the differential value from the high switch point.

Contact functions

(see also "Type Number Selection" table)

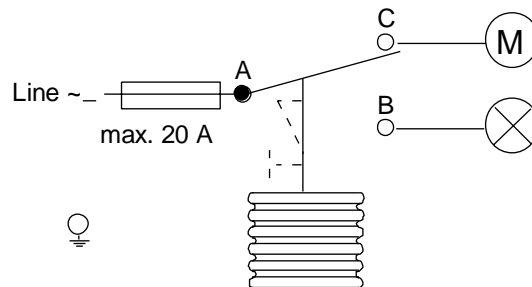

A - C open on pressure decrease
Fig. 1

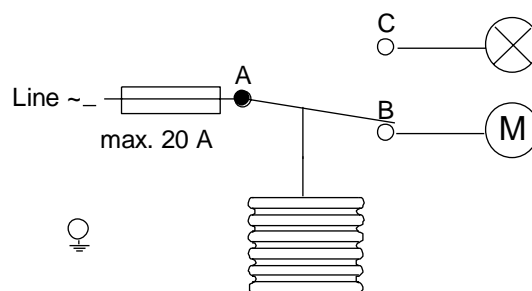

A - B open on pressure increase
Fig. 2

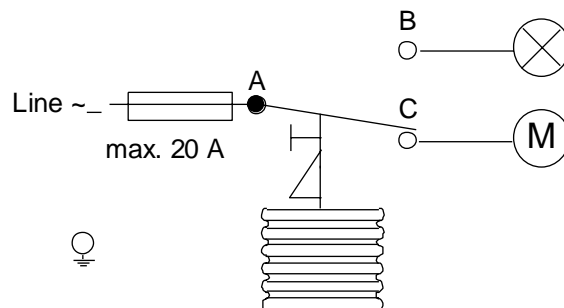

A - C open on pressure increase
Fig. 3

Optional construction note

If your requirements are not in the type number selection table, then please contact your Johnson Controls representative.

Repair and replacement

Repair is not possible. In case of an improperly functioning control, please check with your nearest supplier. When contacting the supplier for a replacement you should state the type/model number of the control. This number can be found on the data plate or cover label.

Type number selection table

Pressure controls for Non-corrosive refrigerants

Family Code	Style 5			Style 30	Range (bar)	Diff. (bar)	Contact function (Figure)	Max. Bellows pressure
	Ind. Pack.	Code***	Bulkpack	Ind. Pack.				
P77AAA	-9300	P77L	-9320	-9400	-0.5 to 7	0.5 to 3	1	22
	-9301				-0.2 to 10	1 to 4.5	1	15
	-9302		-9322		-0.3 to 2	0.4 to 1.5	1	4
	-9350	P77H	-9370	-9450	3 to 30	3 to 12	2	33
	-9351	P77A	-9371	-9451	3.5 to 21	2.1 to 5.5	2	30
P77BCA	-9300		-9320	-9400	-0.5 to 7	Man. res.**	1	22
P77BEA	-9350	P77HR	-9370	-9450	3 to 30	Man. res.*	3	33

*** Only individual package

** Resetable at 0.5 bar above cut-out point

* Resetable at 3 bar below cut-out point

Pressure controls for Non-corrosive refrigerants, built in accordance with DIN 32733 and approved by TÜV Germany

Family Code	Style 5			Style 28	Range (bar)	Diff. (bar)	Contact function (Figure)	Max. Bellows pressure	Approved according to PED 97/23EC Cat. IV
	Ind. Pack.	Code***	Bulkpack	Ind. Pack.					
P77AAW	-9300		-9320	-9800	-0.5 to 7	0.5 to 3	1	20	
	-9350	P77W	-9370	-9850	3 to 30	3.5 to 12	2	33	Yes
P77BCB	-9300		-9320	-9800	-0.5 to 7	Man. res.**	1	20	
P77BEB	-9350	P77B	-9370	-9850	3 to 30	Man. res.*	3	33	Yes
P77BES	-9350	P77S	-9370	-9850	3 to 30	Man. res.*	3	33	Yes

*** Only individual package

** Resetable at 0.5 bar above cut-out point

* Resetable at 3.5 bar below cut-out point

Pressure controls for Ammonia and Non-corrosive refrigerants, built in accordance with DIN 32733 and approved by TÜV Germany

Family Code	Style 15		Range (bar)	Diff. (bar)	Contact function (Figure)	Max. Bellows pressure	Approved according to PED 97/23EC Cat. IV
	Ind. Pack.	Bulkpack					
P77AAW	-9700		-0.5 to 7	0.5 to 3	1	20	
	-9750		3 to 30	3.5 to 12	2	33	Yes
P77BEB	-9750		3 to 30	Man. res.*	3	33	Yes
P77BES	-9750		3 to 30	Man. res.*	3	33	Yes

** Resetable at 0.5 bar above cut-out point

* Resetable at 3.5 bar below cut-out point

Pressure controls for Ammonia and Non-corrosive refrigerants

Family Code	Style 15		Range (bar)	Diff. (bar)	Contact function (Figure)	Max. Bellows pressure
	Ind. Pack.	Bulkpack				
P77AAA	-9750	-9770	3 to 30	3.5 to 12	2	33
P77BCA	-9700		-0.5 to 7	Man. res.**	1	20
P77BEA	-9750		3 to 30	Man. res.*	3	33

** Resetable at 0.5 bar above cut-out point

* Resetable at 3 bar below cut-out point

Note: 100 kPa = 1 bar ≈ 14.5 psi

Pressure connections

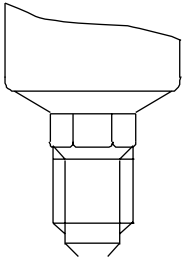

Fig. 4
Style 5
Male connector
7/16"-20 UNF for 1/4"
6 mm flare nut.

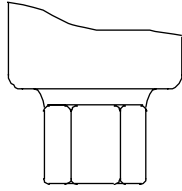

Fig. 5
Style 15
Female connector
1/4"-18 NPT

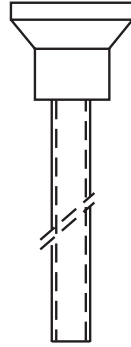

Fig. 6
Style 28
Braze connection
6 mm ODM

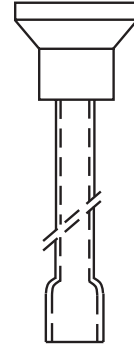

Fig. 7
Style 30
Braze connection
1/4" ODF

Accessories (optional)

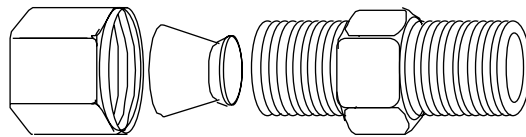

Fig. 8

Description	Application	Order number
Fits into style 15 pressure connectors	For 6 mm copper or steel tubing	CNR003N001R
	For 8 mm copper or steel tubing	CNR003N002R

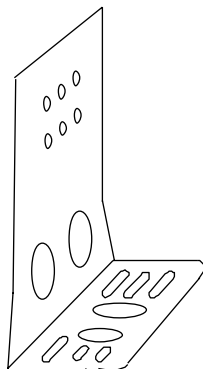

Fig. 9
Mounting bracket
Order number **271-51L**

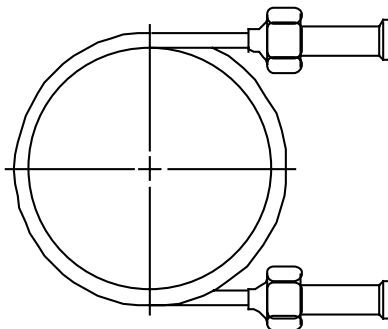

Fig. 10
90 cm Capillary with (2) flare nuts (1/4" SAE)
Order number **SEC002N600**

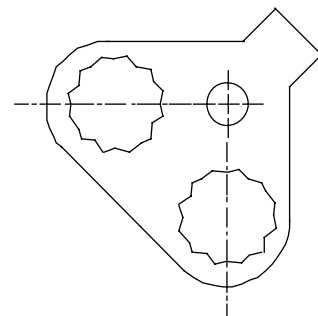
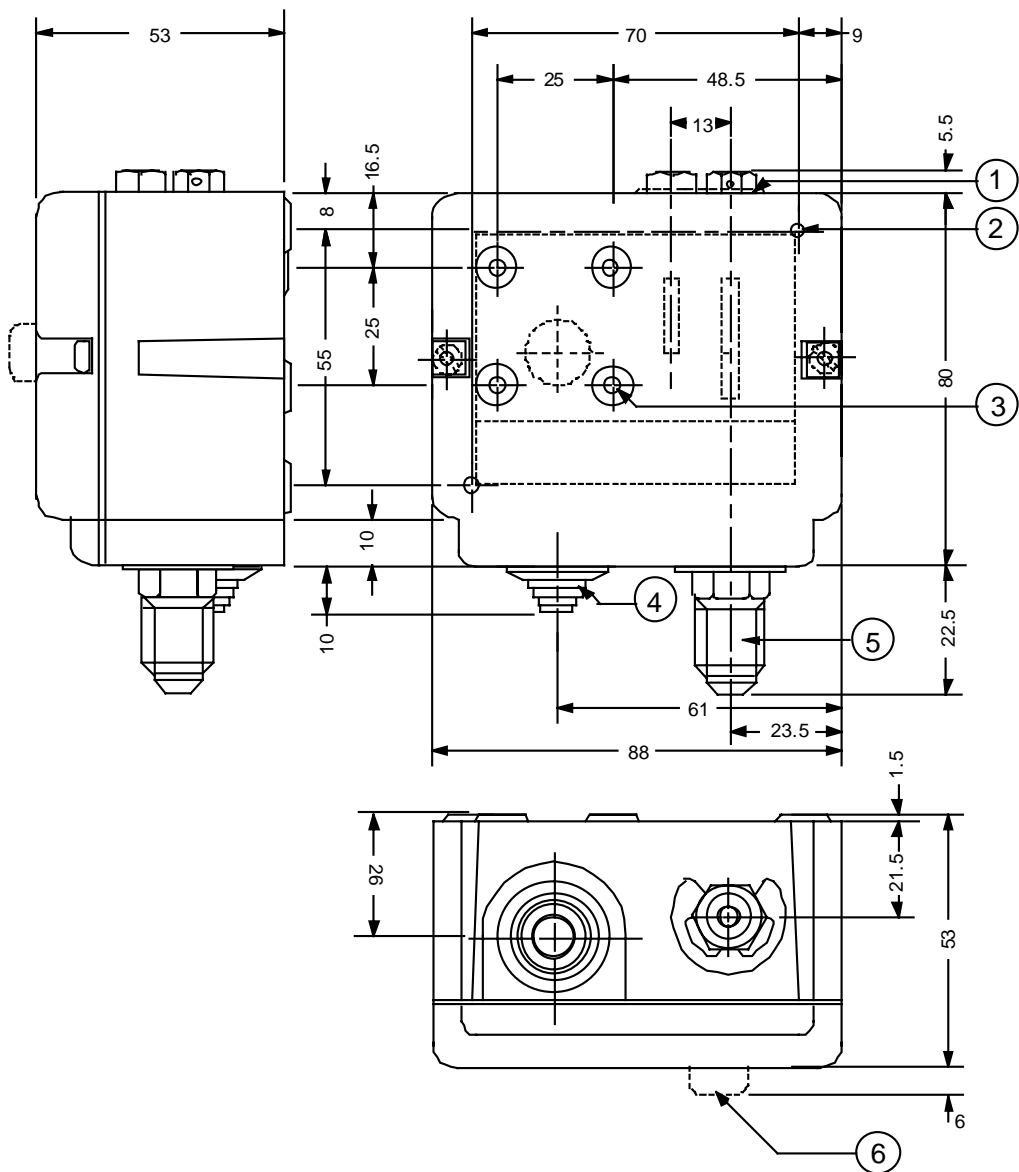

Fig. 11
Locking kit
Order number **KIT023N600**

Dimensions (mm)



1. lock plate (if applied)
2. two mounting holes $\text{\O} 4.5 \text{ mm}$ (knock out)
3. four mounting holes $\text{\O} \text{M4}$ (back side)
4. cable inlet grommet (cable range $\text{\O} 5 \text{ to } \text{\O} 13 \text{ mm}$)
5. power element:
Style 5: $\frac{7}{16}$ "-20 UNF male (shown)
Style 15: $\frac{1}{4}$ "-18 NPT female
6. reset button

Fig. 12

Dimensions (mm)

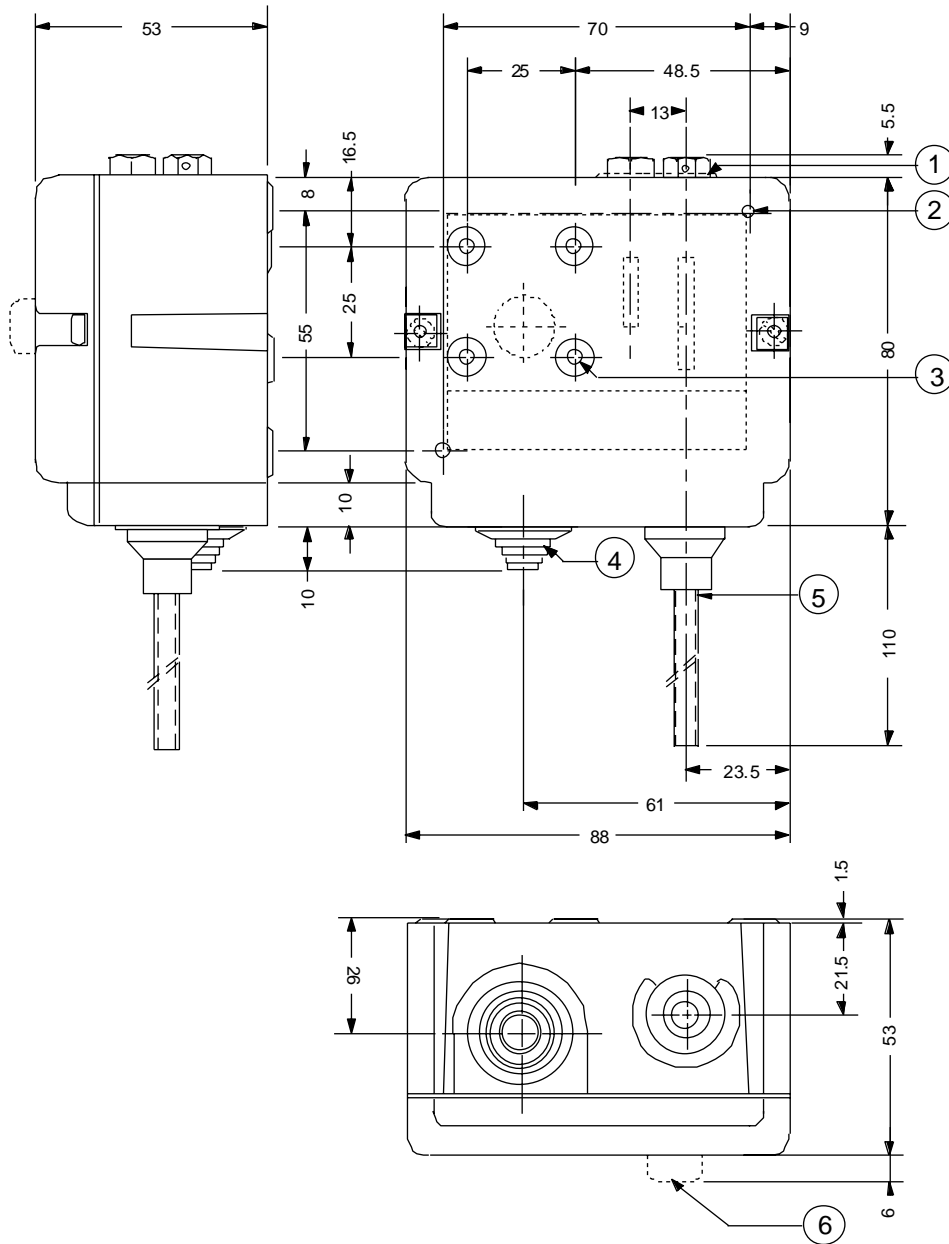

- 1. lock plate (if applied)
- 2. two mounting holes \varnothing 4.5 mm (knock out)
- 3. four mounting holes \varnothing M4 (back side)
- 4. cable inlet grommet (cable range \varnothing 5 to \varnothing 13 mm)
- 5. power element:
 Style 28: Braze connection 6 mm ODM (shown)
 Style 30: Braze connection 1/4" ODF
- 6. reset button

Fig. 13

Notes

Specifications

Pressure connections	Style 5, 15, 28, 30 (see drawings)		
Operating ranges and diff.	See type number selection		
Adjustments	See type number selection		
Ambient temp. limit	-50 to +55 °C (+70 °C max. duration two hours) -20 to +55 °C for DIN and PED approved models		
Electrical ratings	400 Vac 16(10) A 220 Vdc 12 W (pilot duty only)		
Pulsation plug	Fitted into all HP bellows on models with range 3.5 to 21 bar and up		
Locking plate and screw	To lock and seal range and/or differential screw. Standard on types P77AAW, BEB, BES and BCB. Optional on all other types (quantity orders only)		
Protection Class	IP54		
Material	Case and cover	Weatherproof aluminium (die-cast)	
	Contact unit	Large copper-backed silver cadmium contacts (AgCdO) on conductor leaves	
Accessories (see pag. 4)	Mounting bracket Compression coupling 90 cm capillary with two flare nuts		
Shipping weight	ind. pack	0.5 kg	
	-93xx	{	Ind. overpack 36 pcs. (19 kg)
	-97xx		Bulk pack 35 pcs. (18 kg)
	-94xx	{	Ind. overpack 16 pcs. (9 kg)
	-98xx		

The performance specifications are nominal and conform to acceptable industry standards. For applications at conditions beyond these specifications, consult the local Johnson Controls office or representative. Johnson Controls shall not be liable for damages resulting from misapplication or misuse of its products.

**JOHNSON
CONTROLS**

Johnson Controls International, Inc.

Headquarters: Milwaukee, WI, USA
 European Headquarters: Brussels, Belgium
 European Factories: Lomagna (Italy), Leeuwarden (The Netherlands) and Essen (Germany)
 Branch Offices: Principal European Cities.

This document is subject to change

www.johnsoncontrols.com
Printed in Europe

PRODUCT BULLETIN

Series P78
**Dual Pressure Controls for Refrigeration,
 Air-conditioning and Heatpump Applications**

Introduction

These dual pressure controls are designed for use in a variety of applications involving refrigeration high or low pressure. Models supplied have a "whole range" design, enabling them to be used with refrigerants R22, R134A, R404A and all other non-corrosive refrigerants which are within the operating range of the control. They may also be used for other high or low pressure applications such as air, water etc. Models which can be used with ammonia are included in the program. Also models tested and approved to PED 97/23/EC Cat. IV (supersedes DIN and TUV approval) are included in the program.



P78 Dual Pressure Control for Refrigeration

Description

The P78 series pressure controls may be used for control functions or limit functions, depending on model number. All models are provided with alarm contacts (except P78ALA). All standard models have phosphor bronze bellows and brass pressure connections. Models for use with ammonia are provided with stainless steel bellows and connectors. Devices conforming to PED 97/23/EC Cat. IV (HP models) have the fail-safe function with double bellows. Their IP54 classification means that these pressure controls are suitable for almost all applications.

Feature and Benefits

- | | |
|--|--|
| <input type="checkbox"/> Generous wiring space | Easy wiring and maintenance |
| <input type="checkbox"/> Splash-proof enclosure (IP54) | Can be used for indoor/outdoor applications |
| <input type="checkbox"/> Trip-free manual reset | Override is not possible in the control function |
| <input type="checkbox"/> Patented separate alarm contacts for both low pressure and high pressure cut-out (except P78ALA) | Easy monitoring of the fault location |

Note

The controls are intended to control equipment under normal operating conditions. Where failure or malfunctioning of the controls could lead to an abnormal operating condition that could cause personal injury or damage to the equipment or other property, other devices (limit or safety controls) or systems (alarm or supervisory systems) intended to warn of or protect against failure or malfunctioning of the controls must be incorporated into and maintained as part of the control system.

Note

To facilitate order handling special ordering codes have been added to some commonly used models

Type number matrix

P78LCA	Automatic reset both sides
P78MCA	Automatic reset low side manual reset high side
P78PGA	Manual reset both sides
P78LCW	Automatic reset both sides conform PED 97/23/CE
P78MCB	Automatic reset low side manual reset high side conform PED 97/23/CE
P78MCS	Automatic reset low side manual reset high side conform PED 97/23/CE
P78PGB	Manual reset both sides conform PED 97/23/CE
P78PLM	2 x manual rest HP conform PED 97/23/CE
P78ALA	Dual fan cycling control (2 x SPST close high)

Adjustment

On most models the range scale indicates the high switch point (exception: LP side of P78PGA, P78PGB, here the range scale indicates the low switching point). To obtain low switch point deduct differential value from the high switch point.

Repair and replacement

Repair is not possible. In case of an improperly functioning control, please check with your nearest supplier. When contacting the supplier for a replacement you should state the type/model number of the control. This number can be found on the data plate or cover label.

Contact functions

(see also "Type Number Selection" table)

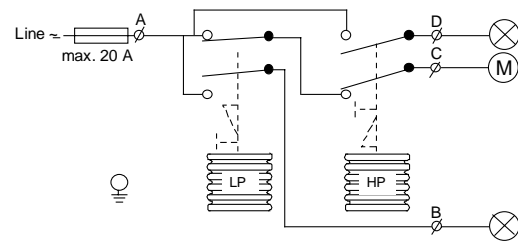

- LP.** A - C opens on pressure decrease
A - B closes simultaneously
- HP.** A - C opens on pressure increase
A - D closes simultaneously

Fig. 1

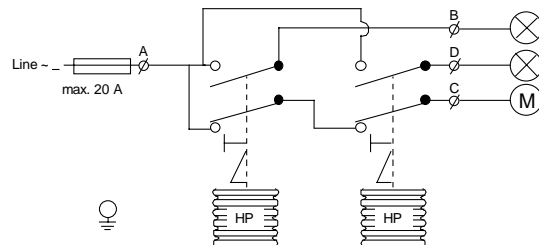

- Left side HP.** A - C opens on pressure increase
A - B closes simultaneously
- Right side HP.** A - C opens on pressure increase
A - D closes simultaneously

Fig. 2

Switching action P78ALA

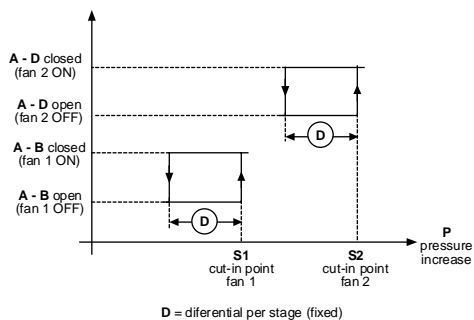

Fig.3a

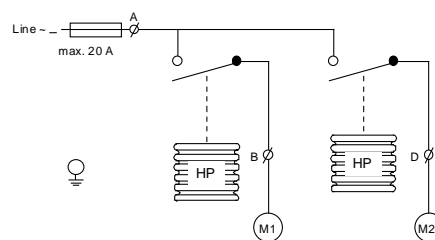

Fig. 3b

Type number selection table

Dual pressure controls for Non-corrosive refrigerants. LP Pmax.: 22bar HP Pmax.:33 bar

Family Code	Pressure Connection				Left Side		Right Side		Contact function (Figure)	Construction
	Style 5			Style 30	Range (bar)	Diff. (bar)	Range (bar)	Diff. (bar)		
	Incl. Pack.	Code***	Bulk-pack	Incl. Pack.						
P78LCA	-9300	P78L	-9320	-9400	-0.5 to 7	0.5 to 3	3 to 30	3 (fixed)	1	LP/HP
P78MCA	-9300	P78M	-9320	-9400	-0.5 to 7	0.5 to 3	3 to 30	Man. res.**	1	

- *** Wholesaler code only for individual pack
 ** Resetable at 3 bar below cut-out point
 * Resetable at 0.5 bar above cut-out point

Dual pressure controls for Ammonia and Non-corrosive refrigerants, LP Pmax.: 20 bar HP Pmax.:33 bar

Family Code	Pressure Connection				Left Side		Right Side		Contact function (Figure)	Construction
	Style 15			Incl. Pack.	Range (bar)	Diff. (bar)	Range (bar)	Diff. (bar)		
	Code***	Bulk-pack	****							
P78LCA	-9700		****		-0.5 to 7	0.5 to 3	3 to 30	3 (fixed)	1	LP/HP
P78MCA	-9700		****		-0.5 to 7	0.5 to 3	3 to 30	Man. res.**	1	
P78PGA	-9700		****		-0.5 to 7	Man. res.**	3 to 30	Man. res.**	1	

- **** Can be set-up for quantity orders
 *** Wholesaler code only for individual package
 ** Resetable at 3 bar below cut-out point
 * Resetable at 0.5 bar above cut-out point

Dual pressure Fan cycling controls for Air-cooled condensers (Non-corrosive refrigerants) HP Pmax.: 30 bar

Family Code	Pressure Connection				Left Side		Right Side		Contact function (Figure)	Construction
	Style 5			Style 30	Range (bar)	Diff. (bar)	Range (bar)	Diff. (bar)		
	Incl. Pack.	Code***	Bulk-pack	Incl. Pack.						
P78ALA	-9351	P78A	****	-9451	3.5 to 21	1.8 (fixed)	3.5 to 21	1.8 (fixed)	3	HP/HP

- **** Can be set-up for quantity orders
 *** Wholesaler code only for individual package
 Note: 100 kPa = 1 bar ≈ 14.5 psi

Dual pressure controls for Non-corrosive refrigerants, (Wächter, Begrenzer, Sicherheitsdruckbegrenzer including lockplate assy) (Except P78PGB-*). LP Pmax.: 20 bar HP Pmax.:33 bar

Family Code	Pressure Connection				Left Side		Right Side		Contact function (Figure)	Approved according to PED 97/23EC Cat. IV
	Style 5			Style 28	Range (bar)	Diff. (bar)	Range (bar)	Diff. (bar)		
	Incl. Pack.	Code***	Bulk-pack	Incl. Pack.						
P78LCW	-9300	P78W	-9320	-9800	-0.5 to 7	0.5 to 3	3 to 30	3 (fixed)	1	Yes
P78MCB	-9300	P78B	-9320	-9800	-0.5 to 7	0.5 to 3	3 to 30	Man. res.**	1	Yes
P78MCS	-9300	P78S	-9320	-9800	-0.5 to 7	0.5 to 3	3 to 30	Man. res.**	1	Yes
P78PGB	-9300	P78P	****	-9800	-0.5 to 7	Man. res.*	3 to 30	Man. res.**	1	Yes
P78PLM	-9350	P78BS	****	-9850	3 to 30	Man. res.**	3 to 30	Man. res.**	2	Yes

- **** Can be set up for quantity orders
 *** Wholesaler code only for individual pack
 ** Resetable at 3.5 bar below cut-out point
 * Resetable at 0.5 bar above cut-out point

Pressure connections

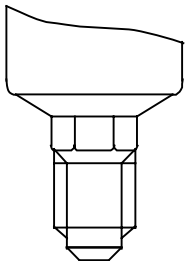

**Fig. 4
Style 5**
Male connector
7/16"-20 UNF for 1/4"
6 mm flare nut.

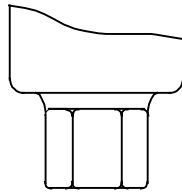

**Fig. 5
Style 15**
Female connector
1/4"-18 NPT

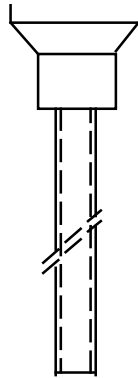

**Fig. 6
Style 28**
Braze connection
6 mm ODM

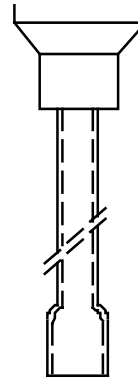

**Fig. 7
Style 30**
Braze connection
1/4" ODF

Accessories (optional)

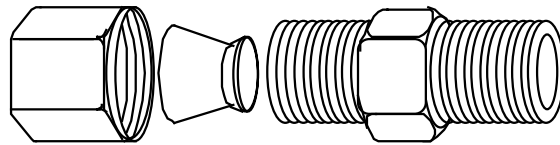

Fig. 8

Description	Application	Order number
Fits into style 15 pressure connectors	For 6 mm copper or steel tubing	CNR003N001R
	For 8 mm copper or steel tubing	CNR003N002R

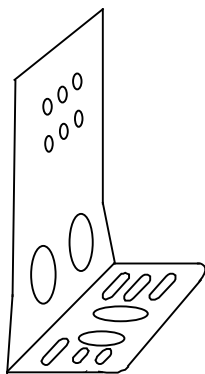

Fig. 9
Mounting bracket
Order number **271-51L**

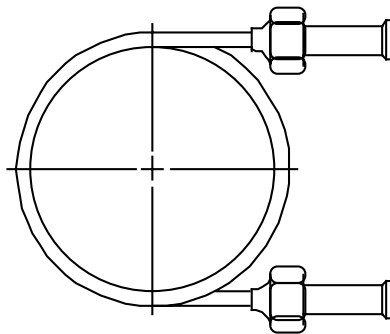

Fig. 10
90 cm Capillary with (2) flare
nuts (1/4" SAE)
Order number **SEC002N600**

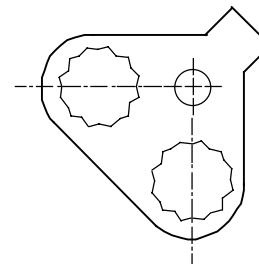
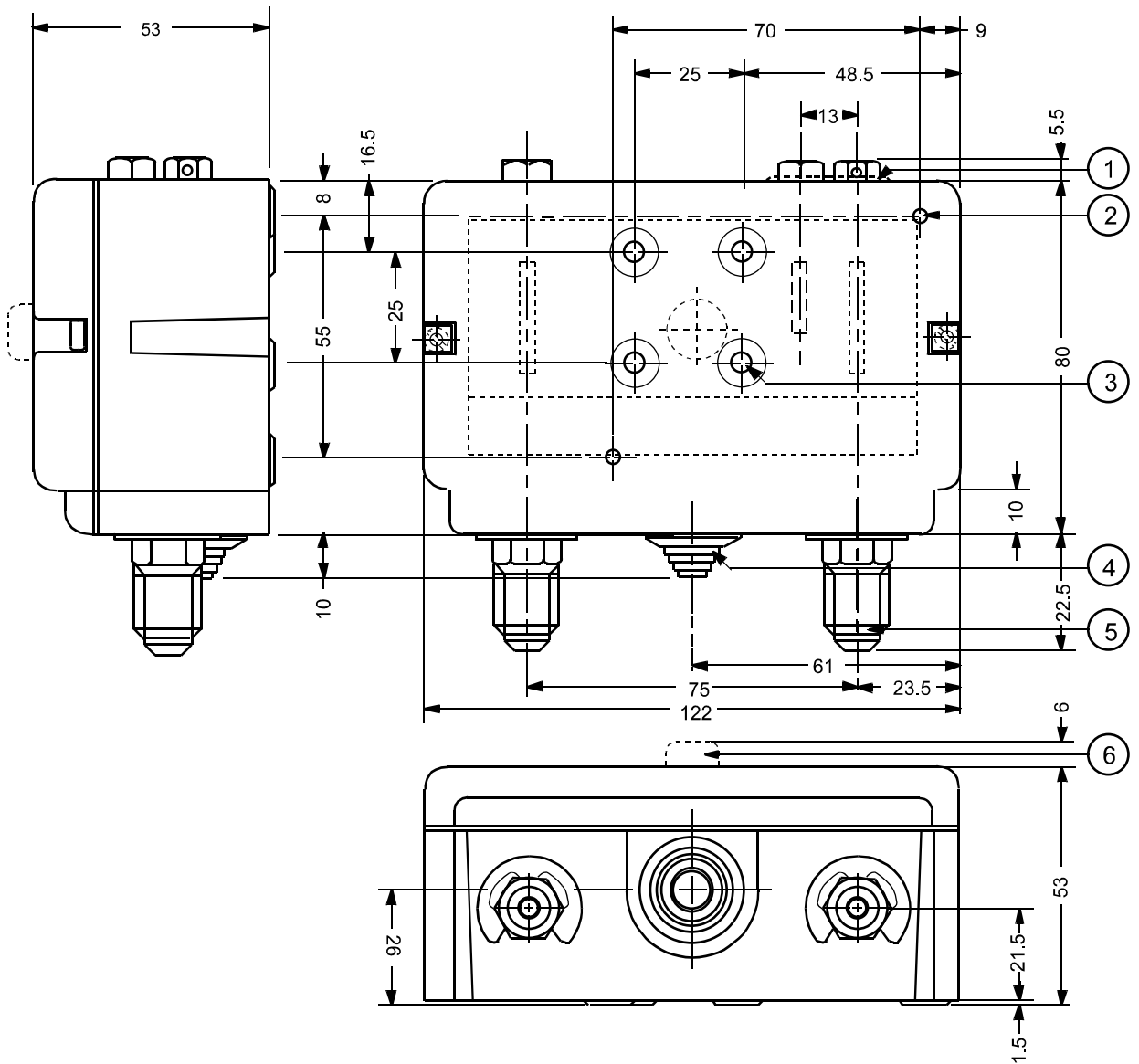

Fig. 11
Locking kit
Order number **KIT023N600**

Dimensions (mm)



1. lock plate (if applied)
2. two mounting holes $\text{\O} 4.5$ mm (knock out)
3. four mounting holes $\text{\O} M4$ (back side)
4. cable inlet grommet (cable range $\text{\O} 5$ to $\text{\O} 13$ mm)
5. power element:
Style 5: $\frac{7}{16}$ "-20 UNF male (shown)
Style 15: $\frac{1}{4}$ "-18 NPT female
6. reset button

Fig. 12

Dimensions (mm)

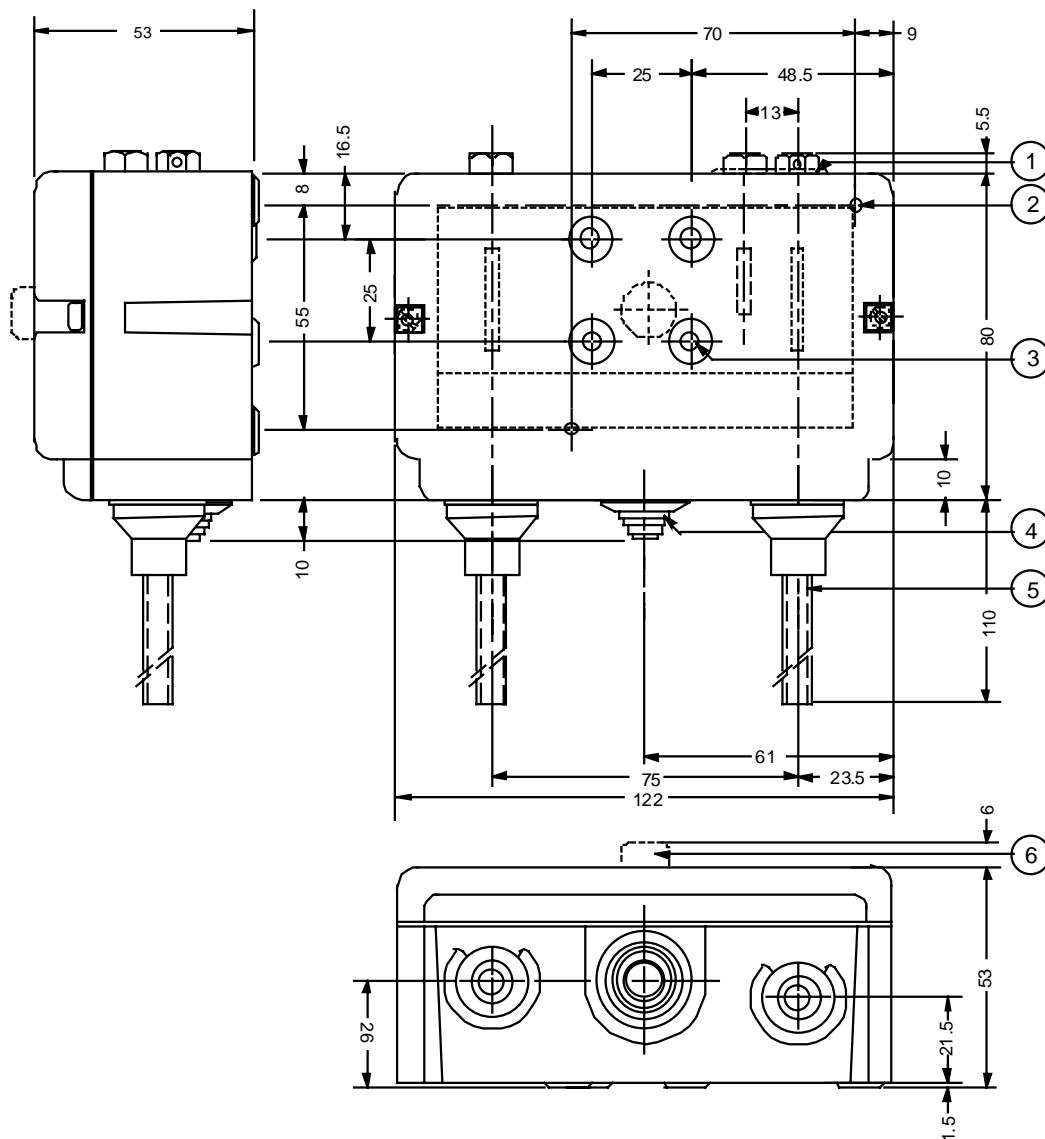

1. lock plate (if applied)
2. two mounting holes $\text{\O} 4.5$ mm (knock out)
3. four mounting holes $\text{\O} M4$ (back side)
4. cable inlet grommet (cable range $\text{\O} 5$ to $\text{\O} 13$ mm)
5. power element:
Style 28: Braze connection 6 mm ODM (shown)
Style 30: Braze connection 1/4" ODF
6. reset button

Fig. 13

Notes

Technical Specifications

Pressure connections	Style 5, 15, 28, 30 (see drawings)		
Operating ranges and diff.	See type number selection		
Adjustments	See type number selection		
Ambient temp. limit	-50 to +55 °C (+70 °C max. duration two hours) -20 to +55 °C for PED approved models		
Electrical ratings	400 Vac	contact A-C	16(10) A
		contact A-B	8(5) A
		contact A-D	8(5) A
	220 Vdc 12 W (pilot duty only)		
Pulsation plug	Fitted into all HP bellows		
Locking plate and screw	To lock and seal range and/or differential screw. Standard on types P78LCW, MCB, MCS, PGB and PLM. Optional on all other types (quantity orders only)		
Protection Class	IP54		
Material	Case and cover	Weatherproof aluminium (die-cast)	
	Contact unit	Large copper-backed silver cadmium contacts (AgCdO) on conductor leaves	
Accessories (see pag. 4)	Mounting bracket Compression coupling 90 cm capillary with two flare nuts		
Shipping weight	ind. pack	0.8 kg	
	-93xx	}	Ind. overpack 30 pcs. (24.5 kg)
	-97xx		Bulk pack 24 pcs. (19.5 kg)
	-94xx	}	Ind. overpack 13 pcs. (11 kg)
	-98xx		

The performance specifications are nominal and conform to acceptable industry standards. For applications at conditions beyond these specifications, consult the local Johnson Controls office or representative. Johnson Controls shall not be liable for damages resulting from misapplication or misuse of its products.



Johnson Controls International, Inc.

Headquarters: Milwaukee, Wisconsin, USA
Branch Offices: Principal Cities World-wide

This document is subject to change

www.johnsoncontrols.com
Printed in Europe

Electrical Control Cabinets Including digital controller

Introduction

Designed to facilitate installers work, this range of electrical cabinet is intended for use in cold rooms working at positive or negative temperatures and powered either with single phase or three phase power supply.

Based on specifically designed controllers, it incorporates all control functions as required by modern cold room units, such as compressor control, defrost management, fan management, alarm function and solenoid valve for "pump down".

It also includes all the safety equipment needed such as circuit breakers for the compressor and for the controller.

Particular attention has been given to the accessibility so that the installation time will be reduced to a minimum. Space has been left available for customisation.



12 modules (front) and 36 modules (back) models

Features and Benefits

<input type="checkbox"/> Power rating from : 0,37 to 1,5 kW in single phase 1,5 to 7,5 kW in three phases	Cover most of standard applications.
<input type="checkbox"/> Standard DIN rail components	Easy maintenance and servicing. Availability of components.
<input type="checkbox"/> Most wiring integrated on the controller	Increased quality and reduced space occupancy.
<input type="checkbox"/> Specifically designed controller to manage Pump Down	Better match application need.
<input type="checkbox"/> Accurate and interchangeable IP 68 sensor	Accurate control performance. No re-calibration needed.
<input type="checkbox"/> IP 65 standard DIN polycarbonate cabinets	High mechanical resistance. Installation in harsh environment.
<input type="checkbox"/> Integrate circuit breaker for motor and controller	No time lost defining appropriate protection
<input type="checkbox"/> In field extension	Possibility to field connect a condensing fan or a door frame heater.
<input type="checkbox"/> Main Switch	To power down the whole cabinet. Increased safety protection.

General features

Controller

Based on the field proven MR family of controllers, it integrates specific features required in cold rooms.

Positive temperature applications:

MR12DR230-1C

- Pump down management (selectable)
- Fan option

Negative temperature applications:

MR15DR230-2C

- Pump down management (selectable)
- Fan management

For additional information please refer to MR documentation

Sensor

The CR series uses Johnson Controls A99 temperature sensor. Its accuracy, ± 0.5 K over a range from -20°C to 75°C , and its gas tight packaging makes it the best sensor for refrigeration applications.

For details please refer to A99 documentation.

Circuit Breaker for motor

(Three phase models only)

Selected for its high protection against short circuit, it features phase disconnection, thermal protection and manual On/Off. The adjusted protection value is independent of temperature condition inside your cabinet.

For details on the short circuit protection, see information page 13.

Circuit Breaker for controller, defrost and fans

Specifically selected for virtually all applications it features a high protection and an appropriate magneto-thermal characteristic in function of the application.

Positive temperature applications:

Mainly inductive loads: Curve D

Negative temperature applications:

Mainly resistive loads: Curve C

Negative temperature applications three phase defrost only:

Mainly inductive loads: Curve D

Defrost Line: Curve C

For details, see information page 13.

Contactors

A VDR protection across the coil extends the life of the controller relays. The contactor, being four (4) poles, allows you to customise the cabinet to your application. This additional contact could be used to drive a condensing fan (up to 3 Amps) or for signalling its operation.

Selected for use in AC-3 category: three-phase motor with cage with a nominal speed of 1500 rpm.

Cabinet

Thanks to a specifically designed MR, there is sufficient space in the cabinet in order to extend your application.

Wiring is easily accessible.

The high protection level (IP65) allows you to install this cabinet in harsh environment such as outdoors. The polycarbonate material has a high shock resistance, which could be necessary during handling or at installation.

The class 2  insulation gives you the safety required by all agencies.

Dimensions (in mm)

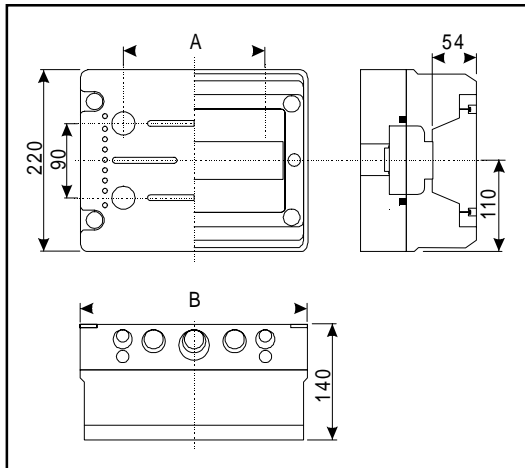

**DIN electrical cabinet
(12 or 18 modules)**

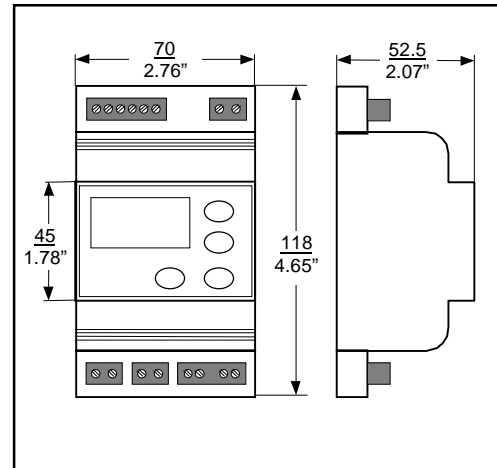

DIN Rail control enclosure

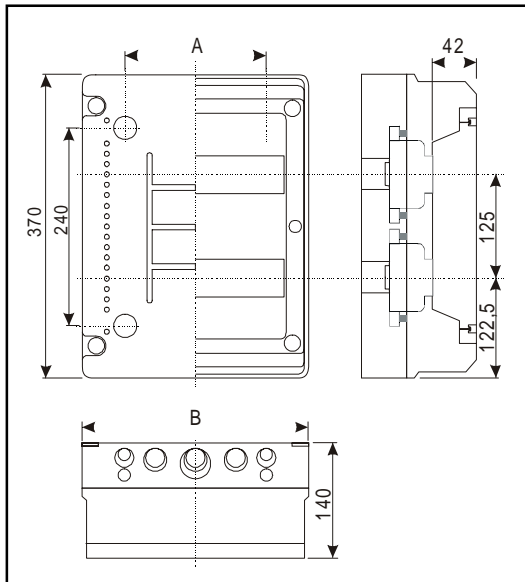

**DIN electrical cabinet
(24 or 36 modules)**

	A	B
12 modules	164	275
18 modules	269	380
24 modules	164	275
36 modules	269	380

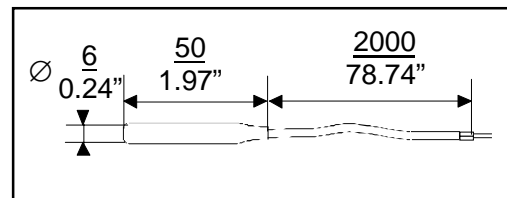

A99B-9108 / A99BB-200C Sensor

Wiring Instruction



WARNING

When wiring and servicing make sure that:

- the electric supply to the actuator is switched off to avoid possible damage to the equipment, personal injury or shock.
- you do not touch or attempt to connect or disconnect wires when electric power is on.

All wiring must be in accordance with local regulations and national rules

These controllers are designed for use as an operating control. When an operating control failure would result in personal injury or loss of property, it is the responsibility of the installer to wire a separate backup control (e.g. a freeze protection thermostat) in order not to use the controller as an operating and safety device.

Positive temperature cold room

Defrost functions

Defrost is initiated and terminated by a timer. The user sets the interval between successive cycles and its duration.

During the defrost cycle, the display can show either the last measurement before this cycle or the setpoint. You can also delay the normal display function after the defrost cycle has ended.

Manual defrost is possible by pushing a key on the controller keypad.

Fan management functions

You can choose whether the fan is to be run in parallel with the compressor or whether it should remain constantly ON. In this case the fan will be ON during defrost. This will decrease defrosting duration.

- | | |
|--|---|
| <ul style="list-style-type: none"> <input type="checkbox"/> Fan and compressor switched in parallel | <ul style="list-style-type: none"> <input type="checkbox"/> Continuous fan |
|--|---|

Pump down selection

A selector is available to choose between the start stop strategy for the compressor.

- | | |
|---|--|
| <ul style="list-style-type: none"> <input type="checkbox"/> Solenoid valve and compressor switched in parallel | <ul style="list-style-type: none"> <input type="checkbox"/> Pump down |
|---|--|

Condensing fan

On the 3-phase models, two terminals are available to field connect a condensing fan.

Digital input functions

All defrost controllers are equipped with a digital input performing the following functions:

- Shut-OFF: If the contact is open for a preset time, all outputs are de-energised and an alarm message is displayed.
- External alarm: Display shows AL, the Alarm output is switched ON, all other functions will perform as normal
- Door open: In this case the High alarm will be disabled, other functions will perform as normal.

Note:

A detailed list of available parameters and their description can be found at the end of this documentation.



Positive Temperature Cold Room Cabinet

Selection table:

Item code	Power supply		Compressor		Evap. Fan Amps	Cond. Fan Amps	Cabinet size modules	Shipping weight Kg
	V ac	Φ	Power AC-3	Amps				
CR-PS037-1	230	1	0,37 kW	5	1,6	-	12	2,2
CR-PS075-1	230	1	0,75 kW	8	1,6	-	12	2,2
CR-PS110-1	230	1	1,1 kW	10	3,2	-	12	2,2
CR-PS150-1	230	1	1,5 kW	12	4,8	-	12	2,2
CR-PT150-1	400	3	1,5 kW	3,5	3,2	3	18	3,2
CR-PT250-1	400	3	2,5 kW	5,7	3,2	3	18	3,2
CR-PT400-1	400	3	4,0 kW	8,5	4,8	3	18	3,2
CR-PT550-1	400	3	5,5 kW	11,5	4,8	3	18	3,2
CR-PT750-1	400	3	7,5 kW	15,5	4,8	3	18	3,2

Wiring diagram

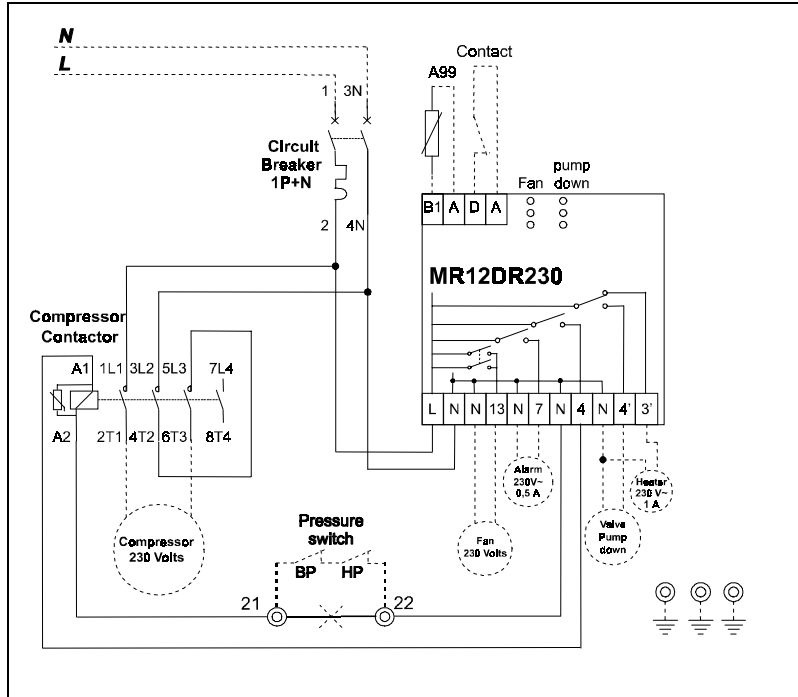

Positive temperature cold room single phase model

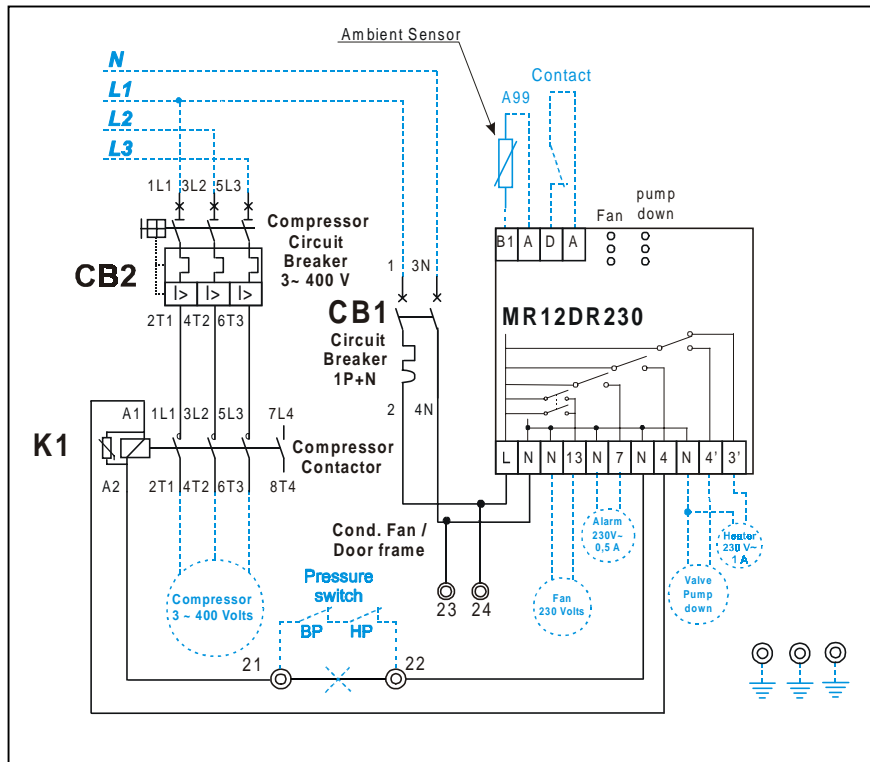

Positive temperature cold room three phase model

Negative temperature cold room

This control is equipped with two sensors, one for the control of the refrigeration unit, the other senses the evaporator temperature.

Defrost functions

Defrost cycle is initiated by a timer and terminated either by temperature or time, whichever comes first.

The defrost function includes the following parameters:

- Type of defrosts (Hot gas or electrical heating).
- Interval time to adjust defrost frequency.
- Type of defrosts termination: time or temperature.
- Defrost end temperature.
- Maximum defrosts duration.

You can stop the compressor for an additional configurable period called dripping time. This will allow the evaporator to dry prior to resuming normal operation.

In case of evaporator sensor failure, defrosts cycle will be terminated by the maximum defrost duration.

During defrost the display can be configured to show the last measurement before defrost or the setpoint.

Fan management functions

Through the controller, you can choose whether the fan is to be run in parallel to the compressor or constantly ON. In any case the fan is switched OFF during defrost.

After defrost, the fan can resume its work after a preset time or after the evaporator temperature has dropped below a user-settable temperature.

Condensing fan or door frame heater

On the 3-phase models, two terminals are available to field connect a condensing fan or a door frame heater to avoid the cell door sticking.

Digital input functions

All defrost controllers are equipped with an additional digital input which can be configured to perform the following functions:

- "Shut-OFF" function.
- External alarm function.
- "Door open" function.

Pump down selection

A selector is available to choose between the start stop strategy for the compressor

- Solenoid valve and compressor switched in parallel
- Pump down

Note:

A detailed list of available parameters and their description can be found at the end of this documentation.



Negative Temperature Cold Room Cabinet

Selection table:

Item code	Power supply		Compressor		Evap. Fan	Cond. Fan/ Door frame heater	Defrost	Cabinet Size	Shipping weight
	V ac	Φ	Power AC-3	Amps	Amps	Amps	Amps	modules	Kg
CR-NS037-1	230	1	0,37 kW	5	1,6	-	8	12	2,5
CR-NS075-1	230	1	0,75 kW	8	1,6	-	12	12	2,5
CR-NS110-1	230	1	1,1 kW	10	3,2	-	12	12	2,5
CR-NS150-1	230	1	1,5 kW	12	4,8	-	16	12	2,5
CR-NT150-1	400	3	1,5 kW	3,5	3,2	3	12	18	3,5
CR-NT250-1	400	3	2,5 kW	5,7	3,2	3	12	18	3,5
CR-NT400-1	400	3	4,0 kW	8,5	4,8	3	15	18	3,5
CR-NT550-1	400	3	5,5 kW	11,5	4,8	3	15	18	3,5
CR-NT750-1	400	3	7,5 kW	15,5	4,8	3	15	18	3,5

Wiring diagram

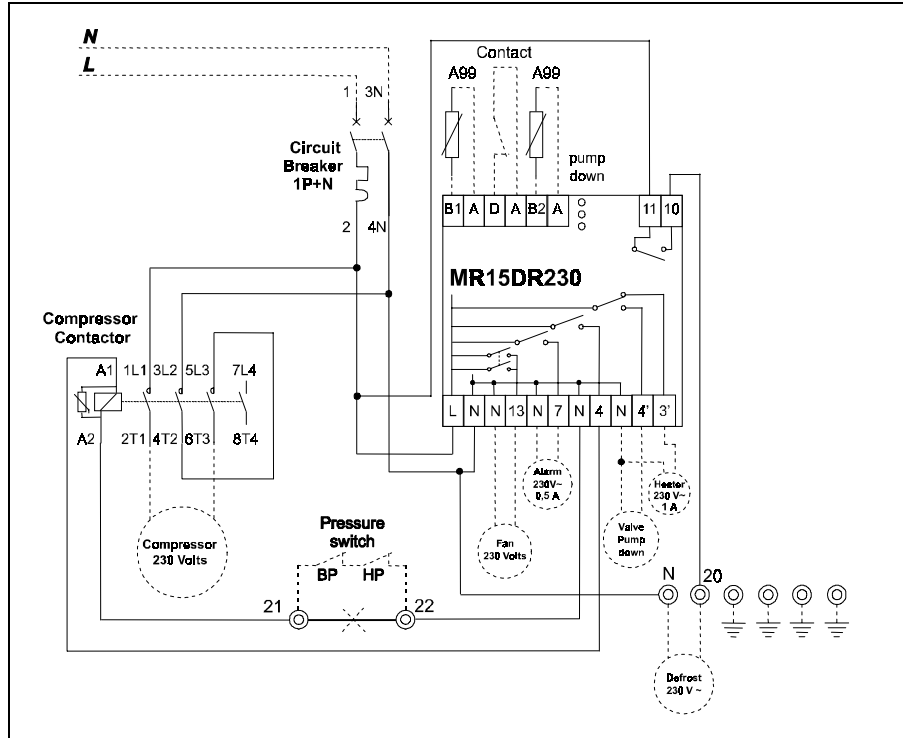

Negative temperature cold room single phase models

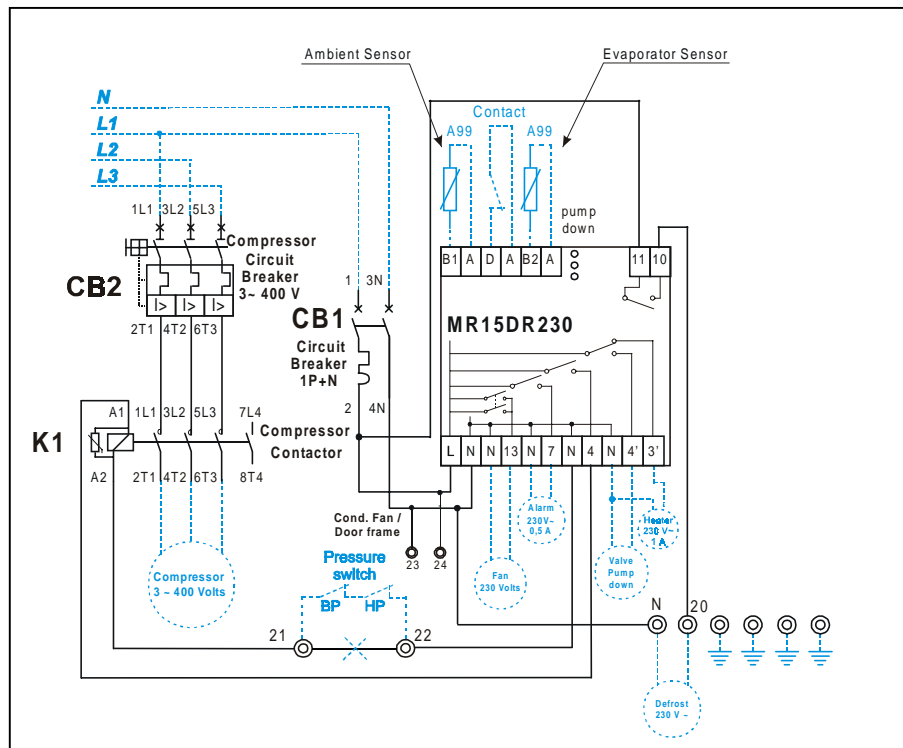

Negative temperature cold room three phase models

Negative temperature cold room with three phase defrost and evaporator fan

Selection table:

Item code	Power supply		Compressor		Evap. Fan	Cond. Fan / Door frame heater	Defrost	Cabinet Size	Shipping weight
	V ac	Φ	Power AC-3	Amps					
CR-NFDT150-1	400	3	1,5 kW	3,5	3 x 2	5	3 x 5	36	5,3
CR-NFDT400-1	400	3	4,0 kW	8,5	3 x 2	5	3 x 10	36	5,3
CR-NFDT750-1	400	3	7,5 kW	15,5	3 x 2	5	3 x 16	36	5,3

Wiring diagram

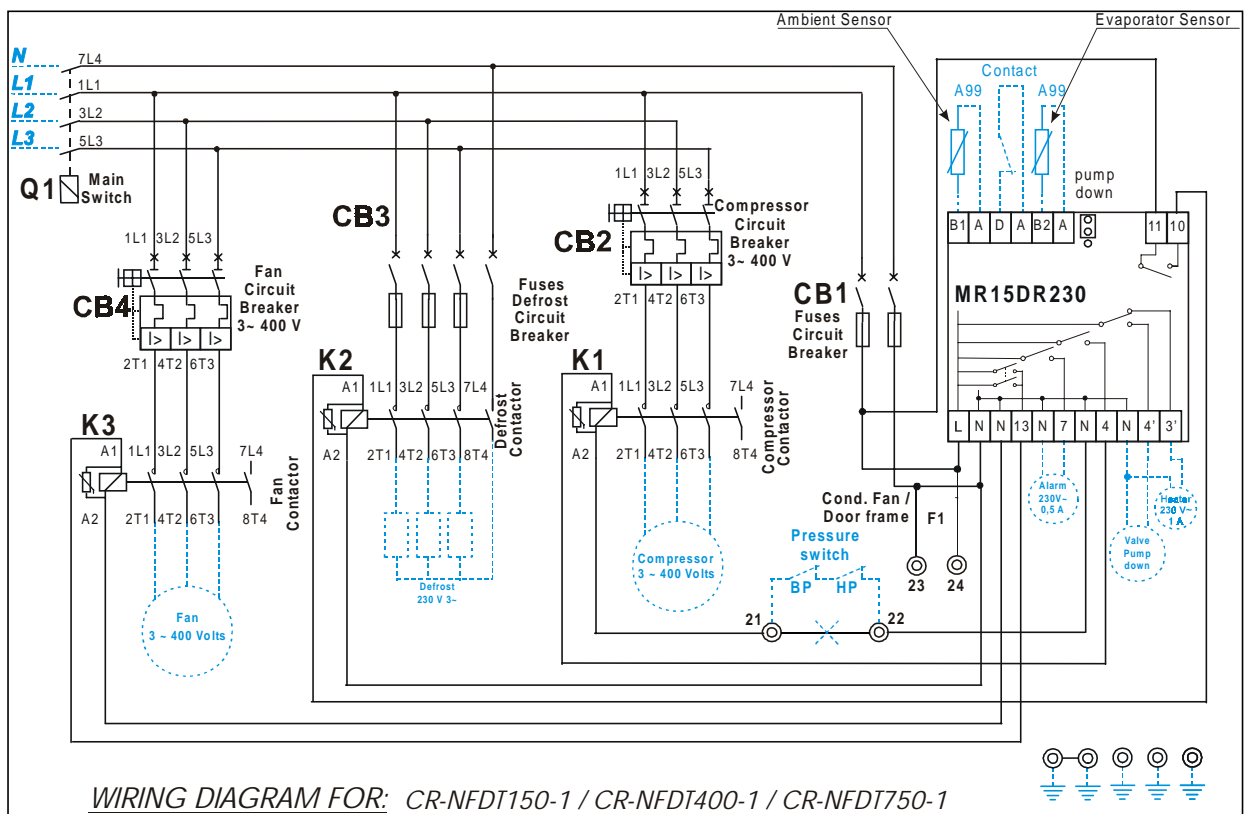

Negative temperature cold room- three phase Compressor, Defrost and Evaporator Fan

Description of each parameter

Setpoint :

is defined as the relay cut OFF.

Hy Hysteresis

This is the difference between the temperature at which the compressor output is switched OFF and the temperature at which the output is switched ON. This is an absolute value, related to the setpoint.

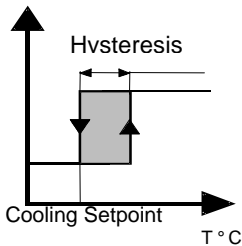

Example:
Cooling Setpoint = 4 °C
Differential = 2 K.
The compressor is switched ON when the temperature goes over 6 °C, and is turned OFF when the temperature decreases to 4 °C.

LL/HL Lower & Higher setpoint limit

The setpoint value cannot be adjusted outside the limits defined by these parameters, to avoid improper setpoint setting by the user.

CC Anti short cycle protection

This parameter prevents the compressor from being turned ON / OFF too often. The value that you set is the minimum time between two subsequent switches ON of the output.

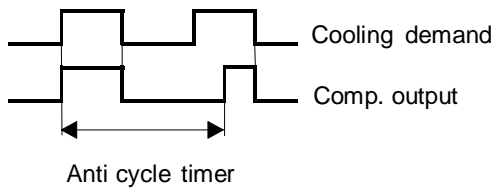

Co Deep freezing time

This is the time for which the compressor is forced ON when pressing the deep freezing cycle key from the faceplate.

AH High temperature alarm:

High temperature alarm value relative to setpoint. If your set point is at 4°C and you want an alarm 5 K above setpoint, it will be triggered at 9°C.

AL Low temperature alarm:

Low temperature alarm value relative to setpoint. If your set point is at 4°C and you want an alarm 3 K below setpoint, it will be triggered at 1°C.

Ad Alarm differential:

Useful to avoid alarm oscillations.

For example:

Setpoint = 4°C,

Max. Temperature alarm = 6 K,

Alarm differential = 2 K.

In this case, when the cold room temperature exceeds $4+6 = 10^\circ\text{C}$ for a time greater than parameter **At** the alarm is activated; when temperature drops below $4+6-2 = 8^\circ\text{C}$ the alarm is reset

At Alarm time delay:

Delay between the detection of the temperature alarm and the activation of the alarm sequences. This is useful to prevent temporary conditions from causing an alarm. Furthermore, the controller automatically ignores the temperature alarm condition in the following cases:

- for 20 minutes after the power-ON
- during defrost and for 20 minutes after the defrost-end.

dF Defrost function:

Select the type of your installation and the way defrost is performed

0 = Electrical defrost (Compressor OFF)

1 = Hot gas defrost (Compressor ON)

dE Defrost end function:

Select the defrost termination type:

0 = timer based, set with parameter **dd**

In this case the evaporator sensor is not required and the fan will restart base on time.

1 = temperature based, set with parameter **dt**

Note: in any case defrost ends after the time set on parameter **dd**.

dt Defrost termination temperature:

Used only when parameter **dE** = 1. When the evaporator temperature reaches this value, defrost automatically ends.

di Defrost interval time:

This is the time between two subsequent defrost cycles. This timer will initiate every defrost cycle.

dd Maximum defrost duration:

If defrost end by time has been selected (parameter **dE**=1) defrost cycle will stop after this time, even if the end temperature has not reached parameter **dt**.

When defrost interval time is 1 hour, the maximum duration is limited to 40 min.

dC Dripping time:

After defrost is terminated, the compressor is stopped to allow the evaporator to drip.

<p>dU First defrost cycle after power-on: This parameter allows to delay a defrost cycle, after power-up. This will prevent a cycle from occurring before the cold room has reached its operation temperature. When set to 'OFF', the first defrost will occur after a complete defrost interval (parameter di)</p> <p>dP Display during defrosts: You can select what to display during the defrost cycle. This is meant to avoid misleading users during the defrost cycle. 0 = last measured value before defrost cycle 1 = setpoint</p> <p>dr Delay displayed temperature after defrost During defrost cycles the ambient temperature is not displayed (see parameter dP). The actual temperature returns to display when its value reaches the setpoint value or, in any case, after the time defined by this parameter.</p> <p>iF Digital input function: The digital input (normally closed) can be configured according to the plant requirements: 0= the DI is not connected 1= If the contact is open for a time longer than that set through parameter id, the plant is switched OFF and an alarm message is displayed; this can be used for condenser alarm... 2= Alarm function: in this case an alarm message is displayed and the alarm digital output is switched ON 3= Open door in the cold room. When the contact is open, the fan is switched OFF (when applicable) and if the contact is open for more than the time set through parameter id an alarm message is displayed and the alarm output is switched ON. High and low alarms are disabled.</p> <p>id Digital input time delay: Time between the detection of the digital input opening and the enabling of the function selected through parameter iF.</p> <p>FF Fan operating function: 0= fan runs in parallel to the compressor 1= fan is always ON <i>Note:</i> in both cases, the fan is switched OFF during the defrost cycle.</p> <p>Fd Fan start-up delay after defrost end: This parameter is a safety function, the fan is activated after this time even if the temperature set through parameter Fr has not been reached</p>	<p>Fr Fan start temperature after defrosts end: Evaporator sensor temperature at which the fan is switched ON, after defrost cycle, <i>Note:</i> in any case the fan is switched ON after the time set through parameter Fd.</p> <p>SF Thermostat operating function when sensor failure: This defines the cycle of the thermostat output in case of failure 0 = Compressor ON 1 = Compressor OFF 2 = Automatic In this mode, the controller will calculate the average time the compressor was ON for the last 4 cycles, and the compressor will run accordingly. If a deep freezing cycle or a defrost cycle occurred, they will not be taken into account nor will the first cycle afterwards.</p> <p>So Offset thermostat sensor: This value is added to or subtracted from the measured value to compensate for possible field measurement offset errors. To compensate for extra long copper cabling use the following formula: $Compensation = -\frac{5 \times length}{1000 \times area} \text{ K}$ Where: <i>length</i> = length of the cable in meters <i>area</i> = section of the cable in square millimetres and compensate for the calculated value</p> <p>Un Temperature units: 0 = Celsius degrees, 1 = Fahrenheit degrees.</p> <p>PU Display updating time delay: The temperature value displayed will be refreshed with this defined period. It will not affect the control performance.</p>
--	---

Parameters :

	Parameter	Setting Range	Default	MR12	MR15
Temperature control parameters					
	Setpoint	-40 to 70°C		•	•
Hy	Hysteresis (HY)	1 to 9 K	2	•	•
LL	Lower setpoint limit (LL)	-40°C to higher limit	-40	•	•
HL	Higher setpoint limit (HL)	lower limit to 70°C	70	•	•
CC	Anti short cycling (CC)	0 to 9 min	2	•	•
Co	Deep freezing time (Co)	0 to 99 min	60	•	•
Alarm parameters					
AH	High. temperature alarm	0 to 50°C related to setpoint	10	•	•
AL	Low temperature alarm	-50 to 0°C related to setpoint	-10	•	•
Ad	Alarm differential	1 to 9 K	1	•	•
At	Alarm time delay	0 to 99 min	30	•	•
Defrost parameters					
dF	Defrost function	0 = Electric heater 1 = Hot gas	0		•
dE	Defrost end function	0= by time 1= by temperature	1		•
dt	Defrost termination temp	0 to 20°C	7		•
di	Defrost interval time	0 to 99 hours	6	•	•
dd	Max. defrost duration	0 to 99 min	40	•	•
dC	Dripping time	0 to 99 min	5	•	•
dU	First defrost after power on	OFF, 0 to 99 min	OF	•	•
dP	Display during defrost	0 = Last value before defrost 1 = Set point	0	•	•
dr	Delay displayed temp after defrost	1 to 99 min	20	•	•
Digital input parameters					
iF	Digital input function	0 = Instrument OFF 1 = Alarm signalling 2 = Alarm reset 3 = Alarm reset and fan cut-off	0	•	•
id	Digital input time delay	0 to 99 sec	5	•	•
Fan control parameters					
FF	Fan operating function	0 = Parallel with compressor 1 = Continuous running	0		•
Fd	Fan start-up delay after defrost end	0 to 99 min.	5		•
Fr	Fan start-up temperature after defrost end	-30 to +5 °C/-22 to 41°F	2		•
Other parameters					
SF	Thermostat operating function when sensor failure	0 = Always ON 1 = Always OFF 2 = Automatic	0	•	•
So	Offset thermostat sensor	-20 to +20 units	0	•	•
Un	Temperature units	0 = °C 1 = °F	0	•	•
PU	Display updating time delay	1 to 99 sec	1	•	•

Characteristic of the general circuit breaker

All models except CR-NDT and CR-NFDT

Interruption capacity	CR-PS CR-PT	CR-NS CR-NT
IEC 898 maximum	I _{cn} = 10 kA	I _{cn} = 6 kA
IEC 898 service	I _{cs} = 10 kA	I _{cs} = 6 kA
IEC 947-2 maximum	I _{cu} = 15 kA	I _{cu} = 10 kA
IEC 947-2 service	I _{cs} = 10 kA	I _{cs} = 7,5 kA
Curve	D	C

CR-NDT Models

Interruption capacity	Defrost	Controller Fan...
IEC 898 maximum	I _{cn} = 6 kA	I _{cn} = 10 kA
IEC 898 service	I _{cs} = 6 kA	I _{cs} = 10 kA
IEC 947-2 maximum	I _{cu} = 10 kA	I _{cu} = 15 kA
IEC 947-2 service	I _{cs} = 7,5 kA	I _{cs} = 10 kA
Curve	C	D

CR-NFDT Models

Defrost and controller in the NFDT models are fuse protected.

For further details refer to manufacturer's documentation (in this case ABB)

Characteristic of the circuit breaker for motor (three phase models only).

Item	Control range	Interruption capacity against short circuit 380-400 Vac I _{cs} (kA)
CR-PT150-1	2,5...4	100
CR-PT250-1	4...6,3	100
CR-PT400-1	6,3...9	100
CR-PT550-1	9...12,5	75
CR-PT750-1	12,5...16	60
CR-NT150-1	2,5...4	100
CR-NT250-1	4...6,3	100
CR-NT400-1	6,3...9	100
CR-NT550-1	9...12,5	75
CR-NT750-1	12,5...16	60
CR-NDT150-1	2,5...4	100
CR-NDT250-1	4...6,3	100
CR-NDT400-1	6,3...9	100
CR-NDT550-1	9...12,5	75
CR-NDT750-1	12,5...16	60
CR-NFDT150-1	2,5...4	100
CR-NFDT400-1	6,3...9	100
CR-NFDT750-1	12,5...16	60

Fuses are not required for a short circuit current below the interruption capacity of the circuit breaker.

For further details refer to manufacturer's documentation (in this case ABB).

Repair, Replacement and Spare-parts

Field repair is limited to change of components such as:

Item Code	Description	Supplier
Digital Controller		
MR12DR230-1C	Digital Controller for positive temperature applications	Johnson Controls
MR15DR230-2C	Digital controller for negative temperature applications	Johnson Controls
A99 sensors		
A99BB-100-1C	Temperature sensor, 1 mt cable, IP68, stainless steel	Johnson Controls
A99BB-200-1C	Temperature sensor, 2 mts cable, IP68, stainless steel	Johnson Controls
<i>Note: In case of defective or improperly functioning control, please check with your nearest Johnson Controls / Penn supplier. When contacting the supplier for replacement, you should state the type or model number of the control. This number can be found on the data plate</i>		
Compressor Contactor		
B7-40-00	Compressor Contactor, up to 5.5 kW	ABB
A16-40-40	Compressor Contactor, 7.5 kW	ABB
Defrost Contactor		
B7-40-00	Defrost Contactor, up to 16 Amps, 3ph	ABB
<i>Alternatively</i>		
LC1K0910M72	Defrost Contactor, 5 and 9 Amps, 3ph	Telemecanique
LC1D1210M7	Defrost Contactor, 10, 12 and 16 Amps, 3ph	Telemecanique
Compressor and Fan Motor Protection		
MS 325 / xx series	Motor protection, see relative amperage value in the wiring diagram	ABB
<i>Alternatively</i>		
GV2-Mxx series	Motor protection, see relative amperage value in the wiring diagram	Telemecanique
Circuit breakers		
S254 Cxx series	Circuit breaker for 3ph defrost, see relative amperage value in the wiring diagram	ABB Elettrocondoture
S271 Na xxx	1ph + N circuit breaker for digital controller, see relative amperage value and characteristic (D or C) in the wiring diagram	ABB Elettrocondoture
<i>Alternatively</i>		
S261-xxx NA series	1ph + N circuit breaker for digital controller, see relative amperage value and characteristic in the wiring diagram	ABB STOTZ
C60x xxx	1ph + N circuit breaker for digital controller, see relative amperage value and characteristic in the wiring diagram	Merlin Gerin
Main Switch		
OT45 E4	3ph main switch for NFDT models	ABB
Cabinet		
12 752	ABS cabinet, IP65, Europa series, 12 modules for CR-PS and CR-NS models	ABB
12 753	ABS cabinet, IP65, Europa series, 18 modules for CR-PT and CR-NT models	ABB
12 754	ABS cabinet, IP65, Europa series, 24 modules for CR-NDT models	ABB
12 755	ABS cabinet, IP65, Europa series, 36 modules for CR-NFDT models	ABB
Security Key		
CR-KEY-1	Cabinet Key lock for increased security, mounting kit	Johnson Controls

Note: In case of defective or improperly functioning element, please check with your nearest electrical equipment supplier. When contacting the supplier for replacement, you should state the type or model number of the control. This number can be found on the data plate. Equivalent equipment can be found from other manufacturers, only ABB products will match electrical requirements within physical dimensions.

Notes

Specifications

Power Supply Requirements	Single phase 230 Vac \pm 10% Three phase 400 Vac \pm 10%	Not all power supplies are available in every version. Please refer to selection tables.
Frequency	50/60 Hz	
Protection Class	IP 65	
Insulation	Class 2 when digital input switch and wire have a dielectric of 1300 Volts	
Ambient Operating Conditions	0° to +40°C (32° to 104°F) 0 to 100 % RH (when properly closed)	
Ambient Storage Conditions	-30° to +80°C (-22° to +176°F) 0 to 95 % RH (non condensing)	
Control range	-40 to +70°C	
Accuracy	\pm 1°C	
Sensor cables	2 meters	
Output ratings	Compressor	See selection table
	Defrost	See selection table
	Fan	See selection table
	Door Frame Heater	
	Pump down	0,1 Amps 230 V ac
	Alarm	0,5 Amps 230 V ac
	Heater	1 Amps 230 V ac
Dimensions (H x W x D)	12 Modules	275 x 220 x 140
	18 Modules	380 x 220 x 140
	24 Modules	275 x 370 x 140
	36 Modules	380 x 370 x 140
Directives	EN 60439-1 Tested Type Appliance (TTA)	

The performance specifications are nominal and conform to acceptable industry standards. For applications at conditions beyond these specifications, consult the local Johnson Controls office or representative. Johnson Controls shall not be liable for damages resulting from misapplication or misuse of its products. This document is subject to change without prior notice.

**JOHNSON
CONTROLS**

Johnson Controls International, Inc.

Headquarters: Milwaukee, WI, USA
 European Headquarters: Westendhof 8, 45143 Essen, Germany
 European Factories: Lomagna (Italy), Leeuwarden (The Netherlands) and Essen (Germany)
 Branch Offices: Principal European Cities.

This document is subject to change

Printed in Europe

Series P215PR

Direct Mount Pressure Actuated Condenser Fan Speed Controllers For Single Phase Motors (incl. built-in RFI suppression filter)

Introduction

These Direct Mount pressure actuated condenser fan speed controllers are designed for speed variation of single-phase motors.

Head pressure control of a refrigeration system, through speed variation of the fan on an air-cooled condenser, results in optimum performance throughout the year.

A pressure actuated device, gives the most direct and fastest response to pressure variations in the refrigerant system. The controller varies the supply voltage to the motor from 30 % to at least 95 % over the proportional band using the phase cutting principle. This provides speed variation of permanent split capacitor or shaded pole motors that do not draw more than 3 A (rms) full load current.

Cut-off models (fan stops at low pressure) as well as minimum speed models (fan keeps running at 30%) are available.

The controllers can be used in non-corrosive refrigerant systems.

The motor manufacturer should have approved his product for this speed control principle.



P215PR
Direct Mount Pressure Actuated
Condenser Fan Speed Controller

It is recommended to confirm with the electric motor manufacturer, that the motor can be used with a controller, using the phase cutting principle for speed variation. You can also provide a copy of this product data sheet to the motor manufacturer/supplier for review.

Feature and Benefits

<input type="checkbox"/> Condenser pressure control by fan speed variation.	Optimum condenser pressure control all the year round. Less noise during colder (night) period.
<input type="checkbox"/> Pressure input.	Direct and fast response to pressure variations.
<input type="checkbox"/> Direct mount.	Easy to install.
<input type="checkbox"/> Setpoint screw on top.	Easy setpoint adjustment after installation.
<input type="checkbox"/> Built-in suppression filter.	The controller meets the electro-magnetic compatibility requirements of the 89/336/EEC directive.
<input type="checkbox"/> IP65	Can be mounted outdoors
<input type="checkbox"/> Compact design	Small turn-around circle. Fits in small units.
<input type="checkbox"/> Attractive styling	Upgrades your equipment
<input type="checkbox"/> Quick connector plug included	For easy wiring and quick replacement

! Caution

The P215PR is intended to control equipment under normal operating conditions. Where failure or malfunction of the P215PR could lead to an abnormal operating condition that could cause personal injury or damage to the equipment or other property, other devices (limit or safety controls) or systems (alarm or supervisory systems) intended to warn of or protect against failure or malfunction of the P215PR must be incorporated into and maintained as part of the control system.

Installation

The controller must be mounted in upright position on the refrigerant line and preferable at the condenser outlet side (to prevent pulsation as much as possible). If a pump-down system is used the pressure connection must be made at the high-pressure side of the system and before the solenoid valve (to avoid low pressures during pump-down). An angle of 45° is allowed to both sides. This to avoid the accumulation of oil inside the bellows and to fulfil class IP65.

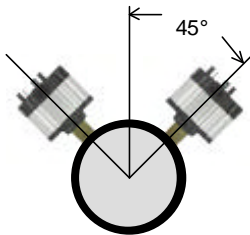

The controller (IP65) can be mounted outdoors. When mounted inside a cabinet, holes for air circulation should be provided. About 4 Watt heat will be generated at the maximum load of 3 A.

Wiring

The built-in EMC filter is designed for a maximum distance of two meters between the controller and the motor. Non-shielded cable must be used. The rubber gasket must be placed between the quick connector plug and the controller terminals to keep the IP65 protection class.

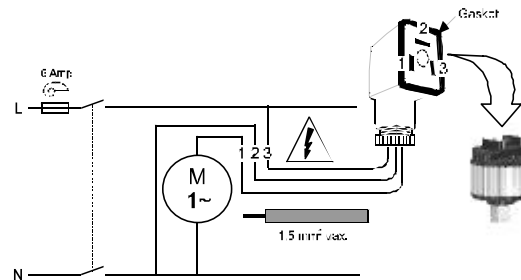

EMC

The controller has a built-in suppression filter and meets all required EC directives. Please note that when two or more EMC compliant components are built together the total system may not be compliant. To make the total system compliant is the responsibility of the producer.

Note

More motors can be wired in parallel, provided that the total current will not exceed the maximum limit.

! Caution

The enclosed quick connector plug is especially designed (special terminal numbering) for this control and should not be used for other purposes.

Measuring

For measuring amps or volts values a true rms meter should be used.

! Caution

The P215PR is not equipped with a power switch. Therefore an additional switch to isolate the device should be used in the power supply wiring to the P215PR. Also the P215PR should be externally fused against miswiring or short circuits. Use a thermal/current overload relay with a current rating according to the motor (max. 6 A/slow).

Adjustments

The setpoint is defined at 90% output value. The fixed min. speed or cut-off value is 30% of the supplied voltage. Please note that the load and the supply voltage can affect the controller characteristic.

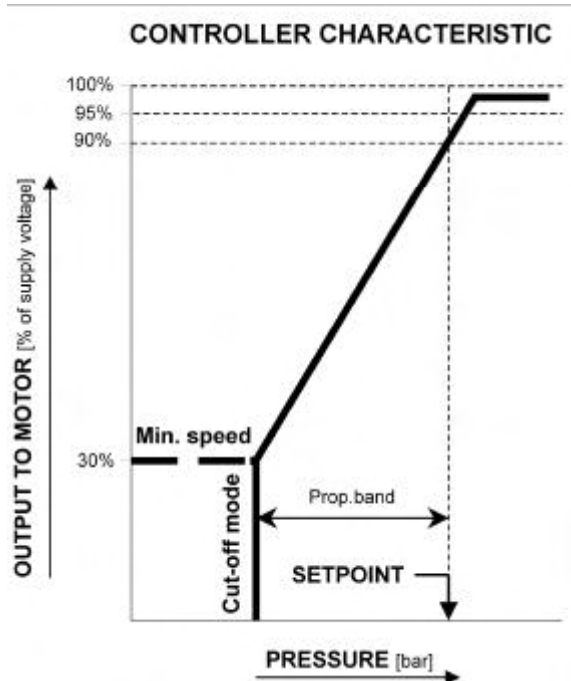

The proportional band is fixed and defined as the pressure difference between the points where the output values are 30% and 90% of the supply voltage.

	Range (bar)	
	10 to 25	22 to 42
Prop. band	4.5 ± 1	5.5 ± 1.5

There is a built-in (fixed) hysteresis. This is not indicated in the control characteristic. The hysteresis is included in the prop. band.

Note

The values indicated are at 50Hz power supply. At 60 Hz the cut-off and proportional band values decrease with 20 %.

SETPOINT SCREW



Setpoint

The pressure setpoint at which your equipment has to work can be adjusted by above setpoint adjusting screw.

The setpoint is factory set at:

range 10 to 25 bar	19 bar
range 22 to 42 bar	26 bar

Repair and replacement

Repair is not possible. In case of an improperly functioning control, please check with your nearest supplier. When contacting the supplier for a replacement you should state the type-model number of the control. This number can be found on the data plate.

Type number selection table

Order nr.	Range (bar)	Element style	Setting (bar)	Prop. band (bar)	Controller Mode
P215PR-9200	10 to 25	47	19	4.5	Cut-off
P215PR-9202	22 to 42	47	26	5.5	Cut-off
P215PR-9800	10 to 25	28	19	4.5	Cut-off

Note: 1 bar = 100 kPa ≈ 14.5 psi

Pressure connections and Dimensions (mm)

There are two types of pressure connections available.



**Style 47 Direct mount
7/16 -20 UNF female
(incl. valve depressor)**

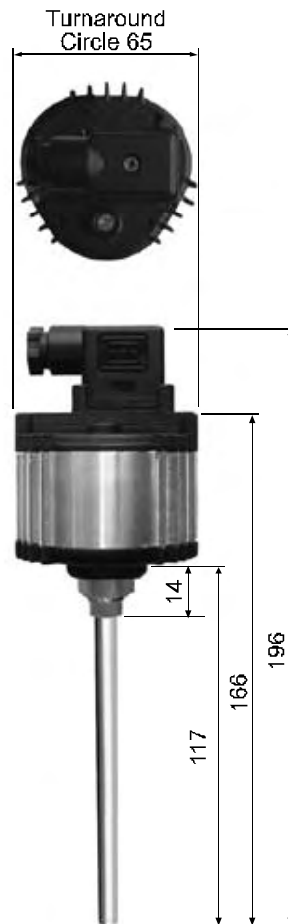

Style 28 Braze connection 6 mm ODM

Note

Specifications

Product type	P215PR
Pressure range	10 to 25 bar 22 to 42 bar
Maximum overrun pressure	22 to 42 bar = 48 bar 10 to 25 bar = 40 bar
Pressure connection	style 47 (7/16-20UNF female incl. valve depressor) style 28 (with 100 mm tube 6 mm ODM)
Control action	direct
Maximum output voltage	≥ 95 % of supply voltage
Maximum current	3 A rms (at maximum voltage output) Special models up to 4 A are possible. Please contact your supplier.
Minimum current	≥ 100 mA
Power factor (cosj) motor	≥ 0.6
Mains supply voltage	230 Vac +10 % / -15 %
Mains supply frequency	50/60 Hz
Operating ambient temperature	-20 to +55 °C
Storage ambient humidity.	10 to 98 % R.H. (non-condensing)
Storage ambient Temp.	-40 to 85 °C
Cut-off point /Minimum speed	30 % of supply voltage
Prop. band range	22 to 42 bar = 5.5 ± 1.5 bar
range	10 to 25 bar = 4.5 ± 1 bar
Enclosure	IP65
Material	top/bottom Polycarbonate (glass filled)
	heatsink aluminium
	press. connection Brass
	bellows Phosphor bronze
Shipping weight	individual pack 0,3 kg
Residual current motor	in cut-off mode ≤ 15 mA
Wiring connections	screw terminals 1½ mm ² max. quick connector plug PG9 (6 up to 8 mm cable)

The performance specifications are nominal and conform to acceptable industry standards. For applications at conditions beyond these specifications, consult the local Johnson Controls office or representative. Johnson Controls shall not be liable for damages resulting from misapplication or misuse of its products.

**Johnson Controls International, Inc.**

Headquarters: Milwaukee, WI, USA
 European Headquarters: Westendhof 8, 45143 Essen, Germany
 European Factories: Lomagna (Italy), Leeuwarden (The Netherlands) and Essen (Germany)
 Branch Offices: Principal European Cities.

This document is subject to change

Printed in Europe

Series P215LR/BR

Single/Dual Pressure Input Condenser Fan Speed Controllers For Single Phase Motors (incl. built-in RFI suppression filter)

Introduction

The P215LR is a single pressure input fan speed controller for air cooled condensers. The controller varies the fan speed by directly sensing the pressure changes in a refrigerant circuit.

The P215BR is a dual pressure input fan speed controller for air cooled condensers with dual refrigerant circuits. The controller varies the fan speed by directly sensing the pressure changes of two separate refrigerant circuits. The setpoint of each pressure transducer can be separately adjusted. The controller selects the input with the greatest cooling demand to control the fan speed.

The controllers can be used in non corrosive refrigerant systems and vary the supply voltage to the motor from 45 % to \geq 95% of the supplied voltage using the phase cutting principle. If the pressure drops below the adjusted setpoint minus the proportional band, the output to the motor is zero volt or the adjusted min. speed setting. This provides speed variation of permanent split capacitor or shaded pole motors which do not draw more than 3 A (rms) full load current.

The motor manufacturer should have approved his product for this speed control principle. It is recommended to confirm with the electric motor manufacturer, that the motor can be used with a controller, using the phase cutting principle for speed variation.



**P215LR/BR
Condenser Fan Speed Controller**

You can also provide a copy of this P215LR/BR product data sheet to the motor manufacturer/supplier for review.

Feature and Benefits

<input type="checkbox"/> Condenser pressure control by fan speed variation.	Optimum condenser pressure control all the year round. Less noise during colder (night) period.
<input type="checkbox"/> Pressure input.	Direct and fast response to pressure variations. Easy to install
<input type="checkbox"/> Model with heatpump input available	Set output to maximum if 230 V is set on the input
<input type="checkbox"/> Transducers with proven reliability.	More than half a million in use today.
<input type="checkbox"/> Easy accessible setpoint screw.	Setpoint easy adjustable. For use on various non-corrosive refrigerants.
<input type="checkbox"/> Built-in suppression filter.	The control meets the electro magnetic compatibility requirements of the 89/336/EEC directive.
<input type="checkbox"/> Adjustable minimum speed or cut-off selection.	Selection to keep the fan running on (adjusted) minimum rpm or to switch it off.
<input type="checkbox"/> Motor speed action can be reversed by interchanging only two wires.	Easy change over from direct to reverse control action
<input type="checkbox"/> Dual pressure input (BR models).	Can be used on condensers with two separate refrigerant circuits.
<input type="checkbox"/> Small dimensions.	Easy to fit in small units.
<input type="checkbox"/> DIN rail mounted	Quick to install.

Note

The P215LR/BR is intended to control equipment under normal operating conditions. Where failure or malfunction of the P215LR / BR could lead to an abnormal operating condition that could cause personal injury or damage to the equipment or other property, other devices (limit or safety controls) or systems (alarm or supervisory systems) intended to warn of or protect against failure or malfunction of the P215LR/BR must be incorporated into and maintained as part of the control system.

Caution

Because the P215LR/BR is a single phase control, it may be used only with single-phase motors approved by the manufacturer for speed control applications.

Installation

The controller consists of a DIN-rail mounted electronic module type P38AA and one (P215LR) or two (P215BR) pressure transducer(s) type P35AC. It can be installed in any convenient location provided that the ambient conditions are suitable for the IP20 enclosure, within the specified limits regarding temperature and humidity and normal pollution situation. More motors can be wired in parallel provided that the total full load current does not exceed 3 Amp (rms). Enclosed mounting bracket(s) can be used.

Note

For style 50 and 51 pressure connections two copper sealrings (one spare) are delivered with the control. Each time the pressure connection is removed this sealing has to be replaced.

Wiring (see fig. 1)

To meet the EMC directive shielded cable has to be used for motor wiring in case the distance between controller and motor is more than 2 meters. If the distance is less than 2 meters it is allowed to use non-shielded cable.

Non shielded cable may be used if the control and motor are mounted in one frame.

If the distance between the transducer(s) and the controller exceeds two metres shielded cable has to be used (The shield can be connected under the screw used to connect the transducer(s) to the mounting bracket(s)).

Both sides of the shield (motor and pressure transducer(s) wiring) have to be connected to earth. To prevent stray current, the earth connections of the transducer(s), the controller, the motor as well as the cable shield, all have to be connected to one earthing pole.

Enclosed quick connector plug(s) can be used to connect wires to the transducer(s).

Heatpump model

On the heatpump model an extra input "HP" is available.

Open = cooling mode, fanspeed controlled according to condenser pressure

Close = heating mode, fanspeed to maximum

EMC

The controller does have a built-in suppression filter and meets all required EC directives. Please note that when two or more EMC compliant components are built together the total system may not be compliant. To make the total system compliant is the responsibility of the producer.

Caution

The enclosed quick connector plug(s) is especially designed (special terminal numbering) for this control and should not be used for other purposes. Take care to connect the correct wires when the original connector is replaced by a non Johnson Controls type.

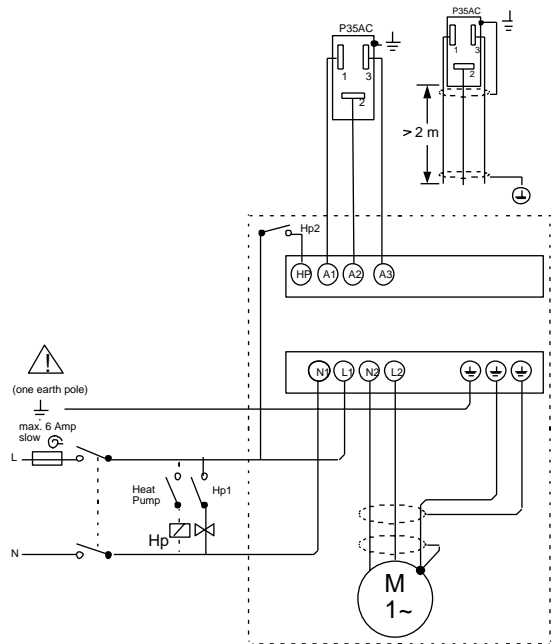

No other connections are allowed within this area. The Hp2 contact must be a separate contact of the Heatpump relay.

230 V Version

Fig. 1a

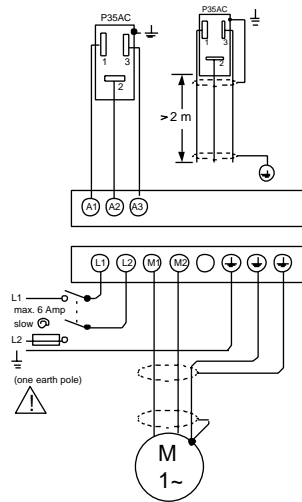

400 V Version
Fig. 1b

! Caution

There will be line voltage on the wiring between the pressure transducer(s) and the electronic module

Control action (direct/reverse)

The wiring as shown in fig. 1 is for direct action (output voltage increases at increasing pressure). If reverse action is desired, this can be obtained by interchanging the wires at terminals 1 and 3 on the pressure transducer(s).

Measuring

For measuring amps or volts values a true rms meter should be used.

! Caution

The P215LR/BR is not equipped with a power switch. Therefore an additional switch to isolate the device should be used in the power supply wiring to the P215LR/BR. Also the P215LR/BR should be externally fused against miswiring or short circuits (max. 6 A slow). Use a thermal/current overload relay with a current rating according to the motor.

Adjustments

The controller gives a control characteristic according to fig.2. The control characteristic can be affected by the load and the supply voltage. The proportional band is fixed and defined as the pressure difference between the points where the output values are 45% and 90% of the supply voltage.

	Range in bar		
	8 to 14	14 to 24	22 to 42
Prop. band	2.5 ± 0.5	4 ± 1	5 ± 2
Δ p (max.)	4	6	8

There is a built-in (fixed) hysteresis. This is not indicated in the control characteristic. The hysteresis is included in the prop. band.

Minimum speed setting

(230 V models only)

The minimum speed voltage setting, to prevent fan speed reduction below desirable levels, can be adjusted between 45 % and 90 % of the line voltage by means of the knob on the electronic module P38AA.

The minimum speed setting influences the proportional band. A higher setting of the minimum speed results in a smaller proportional band.

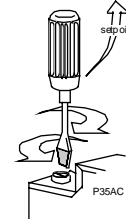
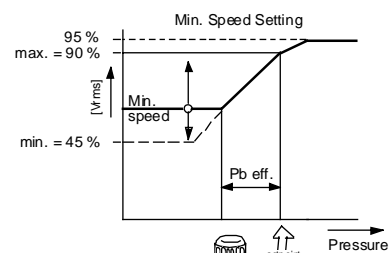
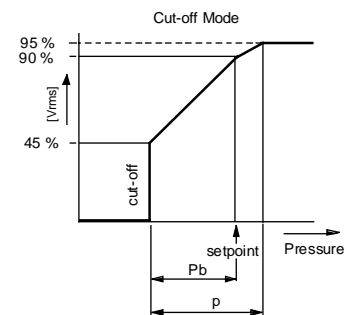

Fig.2

Cut-off mode

If minimum speed is not required, turn the knob on the electronic module to the cut-off mode. The output to the motor drops to 0 V when the pressure decreases below setpoint pressure minus proportional band. (fan stops.)

Setpoint

The pressure setpoint at which your equipment has to work can be adjusted by the range screw (see fig. 2) on the pressure transducer P35AC between 8 to 14, 14 to 24 or 22 to 42 bar.

The setpoint is factory set at:

range 8 to 14 bar	10 bar
range 14 to 24 bar	16 bar
range 22 to 42 bar	30 bar

If it is necessary to make setpoint adjustments care should be taken that the additional transducer does not affect the output voltage of the electronic module P38AA while adjustment is being made on the other transducer. The most safe and easy way to do this, is to disconnect the wiring (blue connector) of the transducer that is not being adjusted.

Repair and replacement

Repair is not possible. In case of an improperly functioning control, please check with your nearest supplier.

When contacting the supplier for a replacement you should state the type-model number of the control. This number can be found on the data plate.

Type number selection table

Order number			Replacement		
Fan speed control	Range (bar)	Element style	Pressure transducer	See Fig.	Electronic module
230 V versions					
P215LR-9114	22 to 42	50	P35AC-9512	7C	P38AA-9111
P215LR-9110	14 to 24	50	P35AC-9500	7A	P38AA-9111
P215LR-9130	Bulk pack version of type P215LR-9110 (15 pcs).			7A	
P215LR-9111	8 to 14	50	P35AC-9501	7A	P38AA-9111
P215LR-9210	14 to 24	47	P35AC-9202	7B	P38AA-9111
P215LR-9211	8 to 14	47	P35AC-9203	7B	P38AA-9111
P215LR-9610	14 to 24	51	P35AC-9507	7A	P38AA-9111
P215LR-9611	8 to 14	51	P35AC-9508	7A	P38AA-9111
P215BR-9110	14 to 24	50	P35AC-9500	7A	P38AA-9211
P215BR-9111	8 to 14	50	P35AC-9501	7A	P38AA-9211
P215BR-9113	22 to 42	50	P35AC-9512	7C	P38AA-9211
P215BR-9210	14 to 24	47	P35AC-9202	7B	P38AA-9211
P215BR-9211	8 to 14	47	P35AC-9203	7B	P38AA-9211

Order number			Replacement		
230 V Heatpump versions	Range (bar)	Element style	Pressure transducer	See Fig.	Electronic module
P215LR-9140	14 to 24	50	P35AC-9500	7A	P38AA-9112

Order number			Replacement		
Fan speed control	Range (bar)	Element style	Pressure transducer	See Fig.	Electronic module
400 V versions					
P215LR-9120	14 to 24	50	P35AC-9510	7A	No replacement

Note: 1 bar = 100 kPa ≈ 14.5 psi

Pressure connections

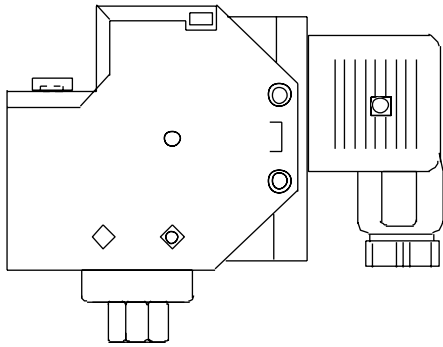

Fig. 3
Style 47 direct mount 7/16 - 20 UNF female
(incl. valve depressor)

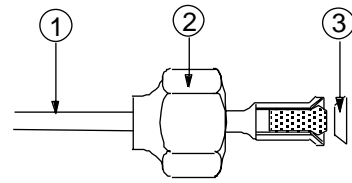

Fig. 4
Style 50 (incl. valve depressor mounted into
machined flare)

1. 90 cm capillary.
2. 7/16 - 20 UNF flare nut.
3. copper sealing

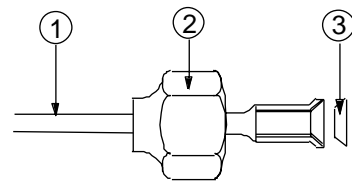

Fig. 5
Style 51 (excl. valve depressor)

Dimensions (mm)
P38AA

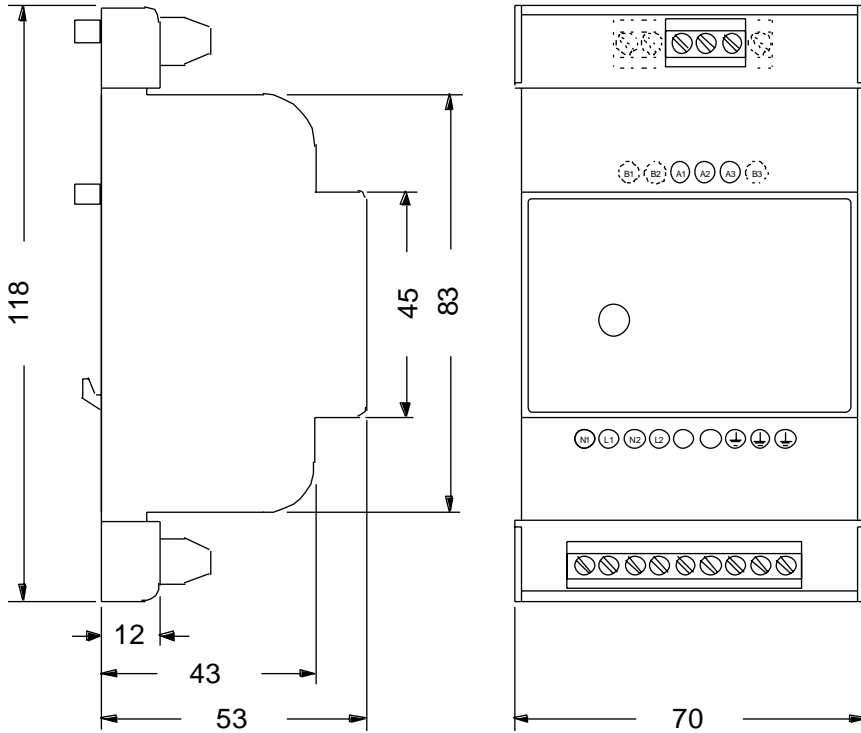

Fig. 6

P35AC

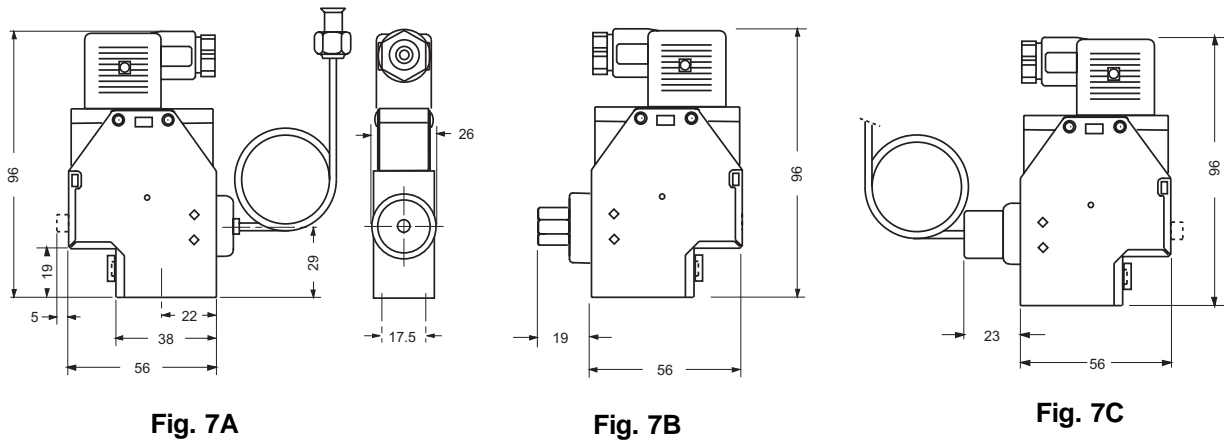

Fig. 7A

Fig. 7B

Fig. 7C

Note

Specifications

Product type	P215LR/BR		
Pressure range	22 to 42 bar 14 to 24 bar 8 to 14 bar		
Maximum overrun pressure	22 to 42 bar = 48 bar 14 to 24 bar = 40 bar 8 to 14 bar = 34 bar		
Pressure connection	style 50 with 90 cm of capillary style 51 with 90 cm of capillary style 47 (direct mount)		
Control action	direct/reverse		
Maximum output voltage	≥ 95 % of supply voltage		
Maximum current	3 A rms (at maximum voltage output)		
Minimum current	≥ 100 mA		
Power factor (cosφ) motor	≥ 0.6		
Mains supply voltage	230 Vac +10 % / -15 % 400 Vac +10 % / -15 %		
Mains supply frequency	50/60 Hz		
Operating ambient temperature	-20 to +55° C		
Operating /storage ambient humidity.	10 to 98 % R.H. (non-condensing)		
Storage ambient Temp.	-40 to 85 °C		
Min. speed	adjustable from 45 to ≥90 % of supply voltage		
Cut-off point	45 % of supply voltage		
Prop. band range	22 to 42 bar = 5 ± 2 bar	at the minimum speed adjustment of 45% of line voltage	
range	14 to 24 bar = 4 ± 1 bar		
range	8 to 14 bar = 2.5 ± 0.5 bar		
Enclosure electronic module	IP20		
pressure transducer	IP20		
Material	enclosure ABS/PC mixture		
Shipping weight	P215LR	individual pack	0.56 kg
		overpack	15 kg (24 pcs.)
		bulkpack	8 kg (15 pcs.)
	P215BR	individual pack	0.85 kg
Residual current motor	in cut-off mode ≤ 15 mA		
Wiring connections	P35AC	screw terminals 1 mm ² up to 1½ mm ²	
	P38AA	screw terminals 1 mm ² up to 2½ mm ²	
Mounting	DIN rail 35 mm.		

The performance specifications are nominal and conform to acceptable industry standards. For applications at conditions beyond these specifications, consult the local Johnson Controls office or representative. Johnson Controls shall not be liable for damages resulting from misapplication or misuse of its products.



Johnson Controls International, Inc.

Headquarters: Milwaukee, WI, USA
 European Headquarters: Brussels, Belgium
 European Factories: Lomagna (Italy), Leeuwarden (The Netherlands) and Essen (Germany)
 Branch Offices: Principal European Cities.

This document is subject to change

www.johnsoncontrols.com

Printed in Europe

Series P215TR

Triple Pressure Input Condenser Fan Speed Controllers For Single Phase Motors (incl. built-in RFI suppression filter)

Introduction

The P215TR is a triple pressure input fan speed controller for air cooled condensers with triple refrigerant circuits. The controller varies the fan speed by directly sensing the pressure changes of three separate refrigerant circuits. Each pressure transducer can be separately adjusted at a setpoint between 8 to 24 bar.

The controller selects the input with the greatest cooling demand to control the fan speed. The controller can be used in non corrosive refrigerant systems. The P215TR varies the supply voltage to the motor from 45% to at least 95 % of the supply voltage using the phase cutting principle. If the pressure drops below the adjusted setpoint minus the proportional band, the output to the motor is zero volt. This provides speed variation of permanent split capacitor or shaded pole motors which do not draw more than 3 A (rms) full load current.

The motor manufacturer should have approved his product for this speed control principle. It is recommended to confirm with the electric motor manufacturer, that the motor can be used with a controller, using the phase cutting principle for speed variation.



**P215TR
Condenser Fan Speed Controller**

You can also provide a copy of this P215TR product data sheet to the motor manufacturer/supplier for review.

Feature and Benefits

<input type="checkbox"/> Condenser pressure control by fan speed variation.	Optimum condenser pressure control all the year round. Less noise during colder (night) period.
<input type="checkbox"/> Pressure input.	Direct and fast response to pressure variations. Easy to install
<input type="checkbox"/> Transducers with proven reliability.	More than half a million in use today.
<input type="checkbox"/> Easy accessible setpoint screw.	Setpoint easy adjustable. For use on various non-corrosive refrigerants.
<input type="checkbox"/> Built-in suppression filter.	The control meets the electro magnetic compatibility requirements of the 89/336/EEC directive.
<input type="checkbox"/> Motor speed action can be reversed by interchanging wires.	Easy change over from direct to reverse action
<input type="checkbox"/> Three pressure inputs.	Can be used on condensers with three separate refrigerant circuits.
<input type="checkbox"/> Small dimensions.	Easy to fit in small units.
<input type="checkbox"/> DIN rail mounted	Quick to install.

Note

These controls are designed for use only as operating controls. Where an operating control failure would result in personal injury or loss of property it is the responsibility of the installer to add devices or systems that protect against, or warn of, control failure.

! Caution

Because the P215TR is a single phase control, it may be used only with single-phase motors approved by the manufacturer for speed control applications.

Installation

The controller consists of a DIN-rail mounted electronic module type P38AA and three pressure transducers type P35AC. It can be installed in any convenient location provided that the ambient conditions are suitable for the IP20 enclosure, within the specified limits regarding temperature and humidity and normal pollution situation. More motors can be wired in parallel, provided that the total full load current will not exceed 3 Amp (rms). Enclosed mounting brackets can be used.

Note

For style 50 pressure connections two copper sealrings (one spare) are delivered with the control. Each time the pressure connection is removed this sealring has to be replaced.

Wiring motor (see Fig. 1)

To meet the EMC directive shielded cable has to be used for motor wiring.

Non shielded cable may be used if the control and motor are mounted in one frame.

If the distance between the transducers and the controller exceeds two metres shielded cable has to be used (The shield can be connected under the screw used to connect the transducers to the mounting brackets).

Both sides of the shield (motor and pressure transducers wiring) have to be connected to earth. To prevent stray current, the earth connections of the transducers, the controller, the motor as well as the cable shield, all have to be connected to one earthing pole.

Enclosed quick connector plugs can be used to connect wires to the transducers.

EMC

The controller does have a built-in suppression filter and meets all required EC directives. Please note that when two or more EMC compliant components are built together the total system may not be compliant. To make the total system compliant is the responsibility of the producer.

! Caution

The enclosed quick connector plugs are especially designed (special terminal numbering) for this control and should not be used for other purposes. Take care to connect the correct wires when the original connector is replaced by a non Johnson Controls type.

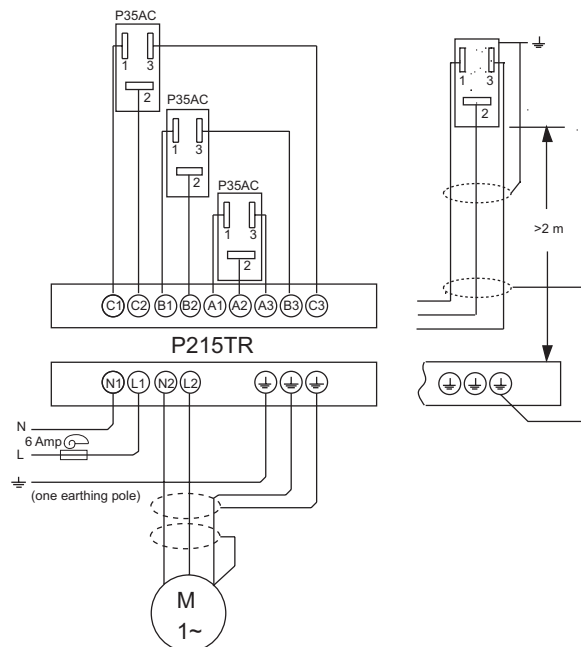
**Fig. 1****! Caution**

There will be line voltage on the wiring between the pressure transducers and the electronic module.

Control action (direct/reverse)

The wiring as shown in fig. 1 is for direct action (output voltage increases at increasing pressure). If reverse action is desired, this can be obtained by interchanging the wires at terminals 1 and 3 on the pressure transducers.

Measuring

For measuring amps or volts values a true rms meter should be used.

Caution

The P215TR is not equipped with a power switch. Therefore an additional switch to isolate the device should be used in the power supply wiring to the P215TR. Also the P215TR should be externally fused against miswiring or short circuits (max. 6A slow). Use a thermal/current overload relay with a current rating according to the motor.

Electro Magnetic Compatibility

The P215 versions have a built-in suppression filter. If connected according to fig. 1 the control meets all required EEC directives.

Adjustments

The electronic module P38AA gives a control characteristic according to fig.2.

The control characteristic can be affected by the load and the supply voltage.

The proportional band is fixed and defined as the pressure difference between the points where the output values are 45% and 90% of the supply voltage.

	Range	
	8 to 14 bar	14 to 24 bar
Prop. band	2.5 ± 0.5 bar	4 ± 1 bar
Δ p (max.)	4 bar	6 bar

There is a built-in (fixed) hysteresis. This is not indicated in the control characteristic. The hysteresis is included in the prop. band.

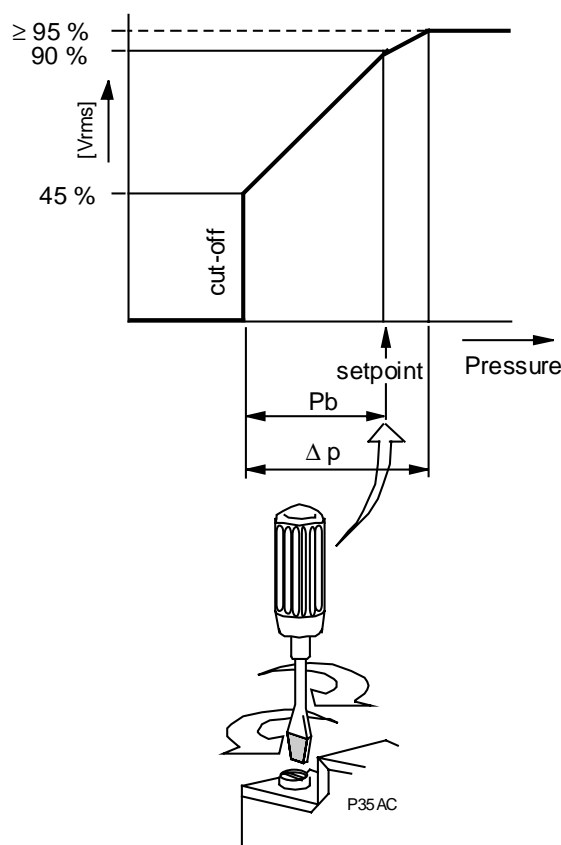

Fig.2

Setpoint

The pressure setpoint at which your equipment has to work can be adjusted by the range screw (see fig. 2) on the pressure transducers P35AC between 8 to 14 or 14 to 24 bar.

The setpoint is factory set at:

range 8 to 14 bar	10 bar
range 14 to 24 bar	16 bar

If it is necessary to make setpoint adjustments care should be taken that the additional transducers do not affect the output voltage of the electronic module P38AA while adjustment is being made on one of the transducers.

The most safe and easy way to do this, is to disconnect the wiring (blue connector) of the transducers that are not being adjusted.

Repair and replacement

Field repair is not possible. In case of an improperly functioning control, please check

with your nearest supplier. When contacting the supplier for a replacement you should state the type-model number of the control. This number can be found on the data plate.

Type number selection table

Order number			Replacement	
Fan speed control	Range (bar)	Element style	Pressure transducer	Electronic module
P215TR-9110	14 to 24	50	P35AC-9500	P38AA-9311
P215TR-9111	8 to 14	50	P35AC-9501	P38AA-9311
P215TR-9210	14 to 24	47	P35AC-9202	P38AA-9311
P215TR-9211	8 to 14	47	P35AC-9203	P38AA-9311

Note: 1 bar = 100 kPa ≈ 14.5 psi

Pressure connections

There are two types of pressure connections available.

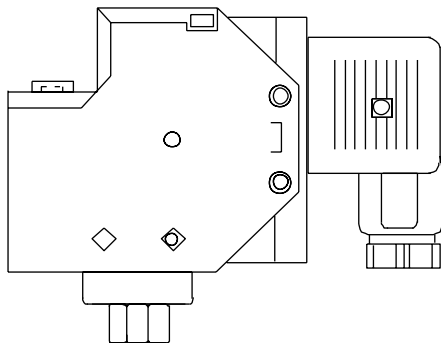

Fig. 3

Style 47 direct mount 7/16 - 20 UNF female (incl. valve depressor)

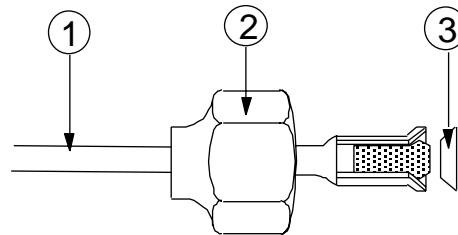

Fig. 4

Style 50 (incl. valve depressor mounted into machined flare)

1. 90 cm capillary.
2. 7/16 - 20 UNF flare nut.
3. copper searing

Dimensions (mm)
P38AA

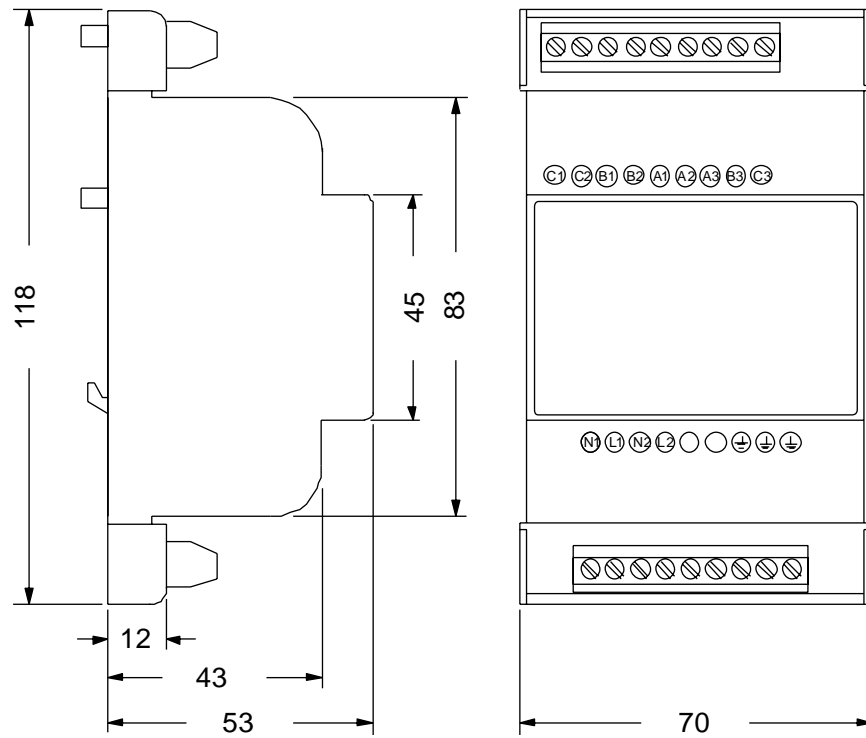

Fig. 5

Capillary types **P35AC** **Direct Mount types**

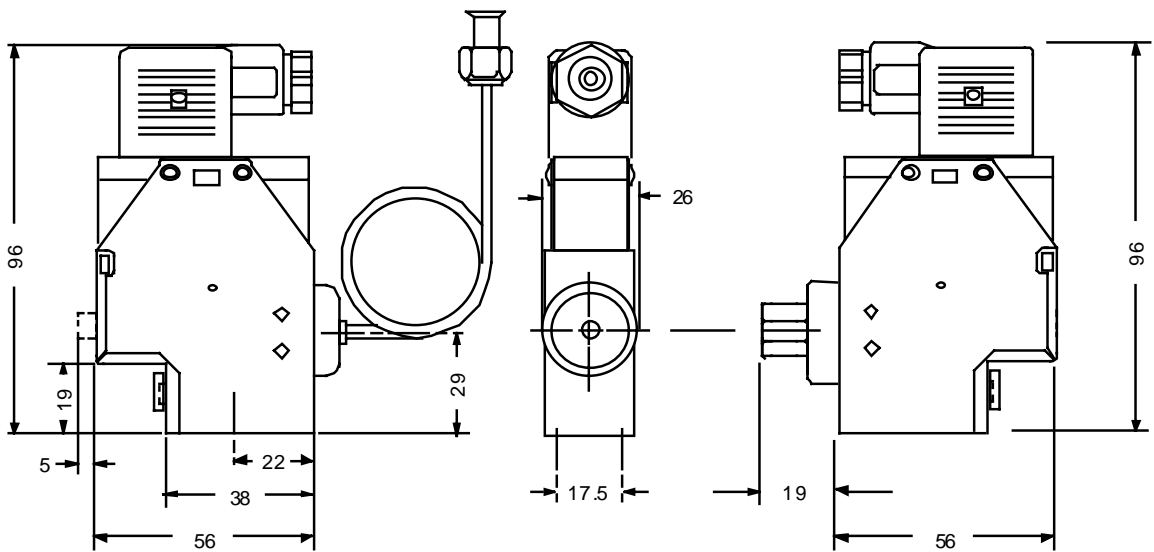

Fig. 6

Notes

Notes

Specifications

Product type	P215TR	
Pressure range	14 to 24 bar 8 to 14 bar	
Maximum overrun pressure	14 to 24 bar = 40 bar 8 to 14 bar = 34 bar	
Pressure connection	style 50 with 90 cm of capillary style 47 (direct mount)	
Control action	direct/reverse	
Maximum output voltage	≥ 95 % of supply voltage	
Maximum current	3 A rms (at maximum voltage output)	
Minimum current	≥ 100 mA	
Power factor (cosφ) motor	≥ 0.6	
Mains supply voltage	230 Vac +10 % / -15 %	
Mains supply frequency	50/60 Hz	
Operating ambient temperature	-20 to +55° C	
Operating /storage ambient humidity.	10 to 98 % R.H. (non-condensing)	
Storage ambient Temp.	-40 to 85 °C	
Min. speed	adjustable from 45 to ≥90 % of supply voltage	
Cut-off point	45 % of supply voltage	
Prop. band range	14 to 24 bar = 4 ± 1 bar	at the minimum speed adjustment of 45% of line voltage
range	8 to 14 bar = 2.5 ± 0.5 bar	
Enclosure electronic module	IP20	
pressure transducer	IP20	
Material	enclosure ABS/PC mixture	
Shipping weight	individual pack	1.6 kg
Residual current motor	in cut-off mode ≤ 15 mA	
EMC	89/336/EEC	
Wiring connections P35AC	screw terminals 1 mm ² up to 1½ mm ²	
P38AA	screw terminals 1 mm ² up to 2½ mm ²	
Mounting	DIN rail 35 mm.	

The performance specifications are nominal and conform to acceptable industry standards. For applications at conditions beyond these specifications, consult the local Johnson Controls office or representative. Johnson Controls shall not be liable for damages resulting from misapplication or misuse of its products.



Johnson Controls International, Inc.

Headquarters: Milwaukee, WI, USA
 European Headquarters: Brussels, Belgium
 European Factories: Lomagna (Italy), Leeuwarden (The Netherlands) and Essen (Germany)
 Branch Offices: Principal European Cities.

This document is subject to change

www.johnsoncontrols.com

Printed in Europe

Series P215SH

Single Pressure Input Condenser Fan Speed Controllers For Single Phase Motors (incl. built-in RFI suppression filter)

Introduction

These controllers are designed for speed variation of single phase motors, especially for fan speed control on air cooled condensers. Head pressure control of a refrigeration system, through speed variation of the fan on an air-cooled condenser, results in optimum performance throughout the year.

Using a pressure transducer as the input device to the fan speed controller, gives the most direct and fastest response to pressure variations in the refrigerant system. The controller varies the supply voltage to the motor from 45 % to at least 95 % over the proportional band using the phase cutting principle. If the pressure drops below the adjusted setpoint minus the proportional band, the output to the motor is zero volt or the adjusted min. speed setting. This provides speed variation of permanent split capacitor or shaded pole motors which do not draw more than 4 A (rms) full load current.

The controller can be used in non-corrosive refrigerant systems. The motor manufacturer should have approved his product for this speed control principle. It is recommended to confirm with the electric motor manufacturer, that the motor can be used with a controller, using the phase cutting principle for speed variation.



**P215SH
 Condenser Fan Speed Controller**

You can also provide a copy of this P215SH product data sheet to the motor manufacturer/supplier for review.

Feature and Benefits

<input type="checkbox"/> Condenser pressure control by fan speed variation.	Optimum condenser pressure control all the year round. Less noise during colder (night) period.
<input type="checkbox"/> Pressure input.	Direct and fast response to pressure variations. Easy to install
<input type="checkbox"/> Heatpump input available	Sets output to maximum if line voltage is set to the input
<input type="checkbox"/> Transducers with proven reliability.	More than half a million in use today.
<input type="checkbox"/> Easy accessible setpoint screw.	Setpoint easy adjustable. For use on various non-corrosive refrigerants.
<input type="checkbox"/> Built-in suppression filter.	The control meets the electro magnetic compatibility requirements of the 89/336/EEC directive.
<input type="checkbox"/> Adjustable minimum speed or cut-off selection.	Selection to keep the fan running on (adjusted) minimum rpm or to switch it off.
<input type="checkbox"/> IP54 enclosure.	Can be mounted outdoor.

Note

The P215SH is intended to control equipment under normal operating conditions. Where failure or malfunction of the P215SH could lead to an abnormal operating condition that could cause personal injury or damage to the equipment or other property, other devices (limit or safety controls) or systems (alarm or supervisory systems) intended to warn of or protect against failure or malfunction of the P215SH must be incorporated into and maintained as part of the control system.

! Caution

Because the P215SH is a single phase control, it may be used only with single-phase motors approved by the manufacturer for speed control applications.

Description

The transducer and electronics are built into an IP54 enclosure.

There are three pressure ranges: 8 to 14 bar
14 to 24 bar
22 to 42 bar

Pressure connections are:

- style 50 - 90 cm capillary/machined flare with valve depressor
- style 51 - 90 cm capillary/machined flare without valve depressor
- style 28 - 15 cm brazing tube 6 mm ODM

Installation

The device is provided with a drain hole at the cable inlet side. To maintain the IP54 protection-class the controller must be mounted in a vertical position to assure a permanent drain function. For proper air-circulation there should be a clearance around the controller of at least 50 mm. When mounted inside a cabinet, holes for air circulation should be provided.

If a pump-down system is used the pressure connection must be made at the high-pressure side of the system, (before the solenoid valve).

Note

For style 50 and 51 pressure connections two copper sealrings (one spare) are delivered with the control. Each time the pressure connection is removed this sealring has to be replaced.

Wiring (see Fig. 1)

To meet the EMC directive shielded cable has to be used for motor wiring in case the distance between controller and motor is more than 2 meters. If the distance is less than 2 meters it is allowed to use non-shielded cable.

Non shielded cable may be used if the control and motor are mounted in one frame.

Both sides of the motor cable shield have to be connected to earth. To prevent stray current, the earth connections of the controller, the motor earth connection as well as the cable shield, all have to be connected to one earthing pole.

EMC

The controller does have a built-in suppression filter and meets all required EC directives. Please note that when two or more EMC compliant components are built together the total system may not be compliant. To make the total system compliant is the responsibility of the producer.

Note

Three earth connections are provided except for the 22-42 bar models which have two earth connections.

More motors can be wired in parallel, provided that the total current will not exceed 4 A rms.

Measuring

For measuring amps or volts values a true rms meter should be used.

! Caution

The P215SH is not equipped with a power switch. Therefore an additional switch to isolate the device should be used in the power supply wiring to the P215SH. Also the P215SH should be externally fused against miswiring or short circuits. Use a thermal/current overload relay with a current rating according to the motor (max. 6 A/slow).

Heatpump input

If line voltage is set to terminal HP the output to the fan goes to $\geq 95\%$ of the supply voltage.

- Contact open = cooling mode, fanspeed controlled according to the condenser pressure.
- Contact closed = heating mode, fanspeed to maximum.

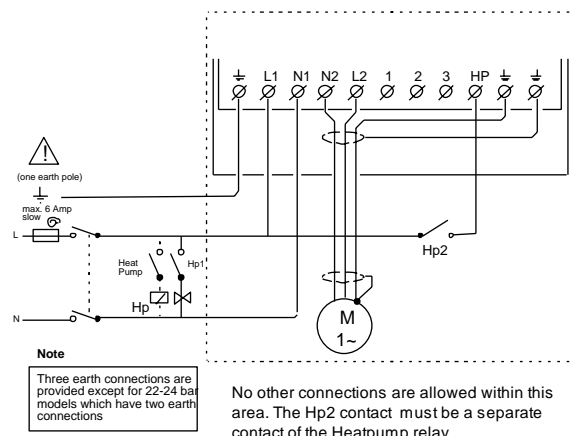

Fig. 1

Adjustments

The P215SH gives a control characteristic according to fig. 2.

The control characteristic can be affected by the load and the supply voltage.

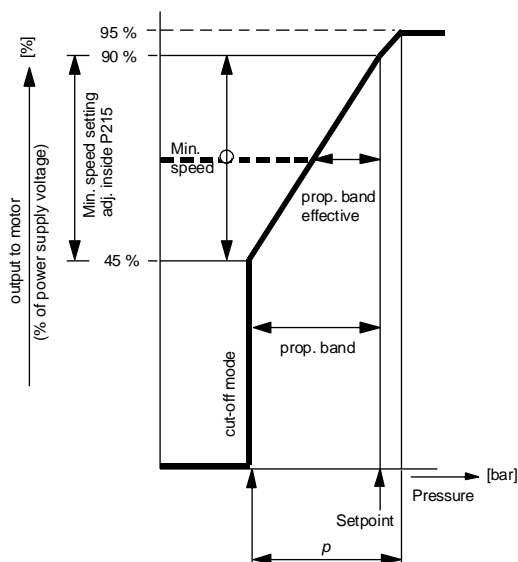

Fig. 2

The proportional band is fixed and defined as the pressure difference between the points where the output values are 45% and 90% of the supply voltage.

	Range in bar		
	8 to 14	14 to 24	22 to 42
Prop. band	2.5 ± 0.5	4 ± 1	5 ± 2
Δ p (max.)	4	6	8

There is a built-in (fixed) hysteresis. This is not indicated in the control characteristic. The hysteresis is included in the prop. band.

Minimum speed setting

The minimum speed voltage setting, to prevent fan speed reduction below desirable levels, can be adjusted between 45 % and 90 % of the line voltage by means of the potentiometer inside the controller (see fig. 3). By turning this potentiometer clockwise into the minimum speed section, the output to the motor stays at a higher level. The minimum speed setting influences the proportional band. A higher setting of the minimum speed results in a smaller proportional band.

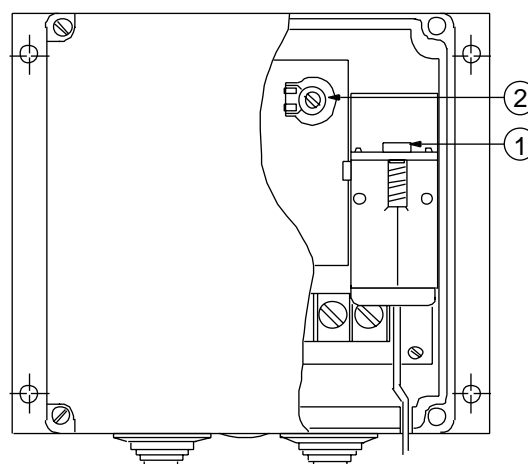

Fig. 3

- 1 Setpoint adjusting screw
- 2 Minimum speed / cut-off potentiometer

Cut-off mode

If minimum speed is not required, turn the potentiometer completely counter-clockwise. The output to the motor drops to 0 V when the pressure decreases below setpoint pressure minus proportional band (fan stops).

Setpoint

The pressure setpoint at which your equipment has to work can be adjusted by the setpoint adjusting screw (see fig. 2 and 3) between 8 to 14, 14 to 24 or 22 to 42 bar.

The setpoint is factory set at:

range 8 to 14 bar	10 bar
range 14 to 24 bar	16 bar
range 22 to 42 bar	30 bar

Repair and replacement

Repair is not possible. In case of an improperly functioning control, please check with your nearest supplier. When contacting the supplier for a replacement you should state the type-model number of the control. This number can be found on the data plate.

*T*ype number selection table

Order nr. (bar)	Range (bar)	Element style	Setting (bar)	Prop. band
P215SH-9102	22 to 42	50	30	5
P215SH-9100	14 to 24	50	16	4
P215SH-9101	8 to 14	50	10	2.5
P215SH-9800	14 to 24	28	16	4

Note: 1 bar = 100 kPa \approx 14.5 psi

*P*ressure connection

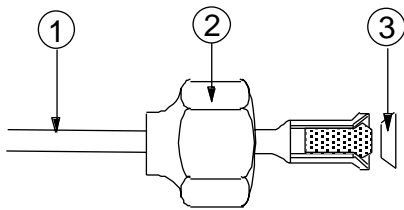

Fig. 4
Style 50 (incl. valve depressor mounted into machined flare)

1. 90 cm capillary.
2. 7/16 - 20 UNF flare nut.
3. copper sealring

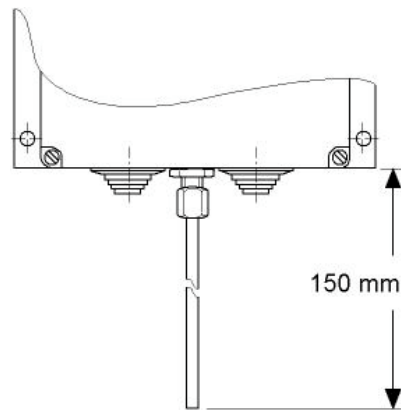

Fig. 6
Style 28 Braze connection 6 mm ODM

Dimensions (mm)

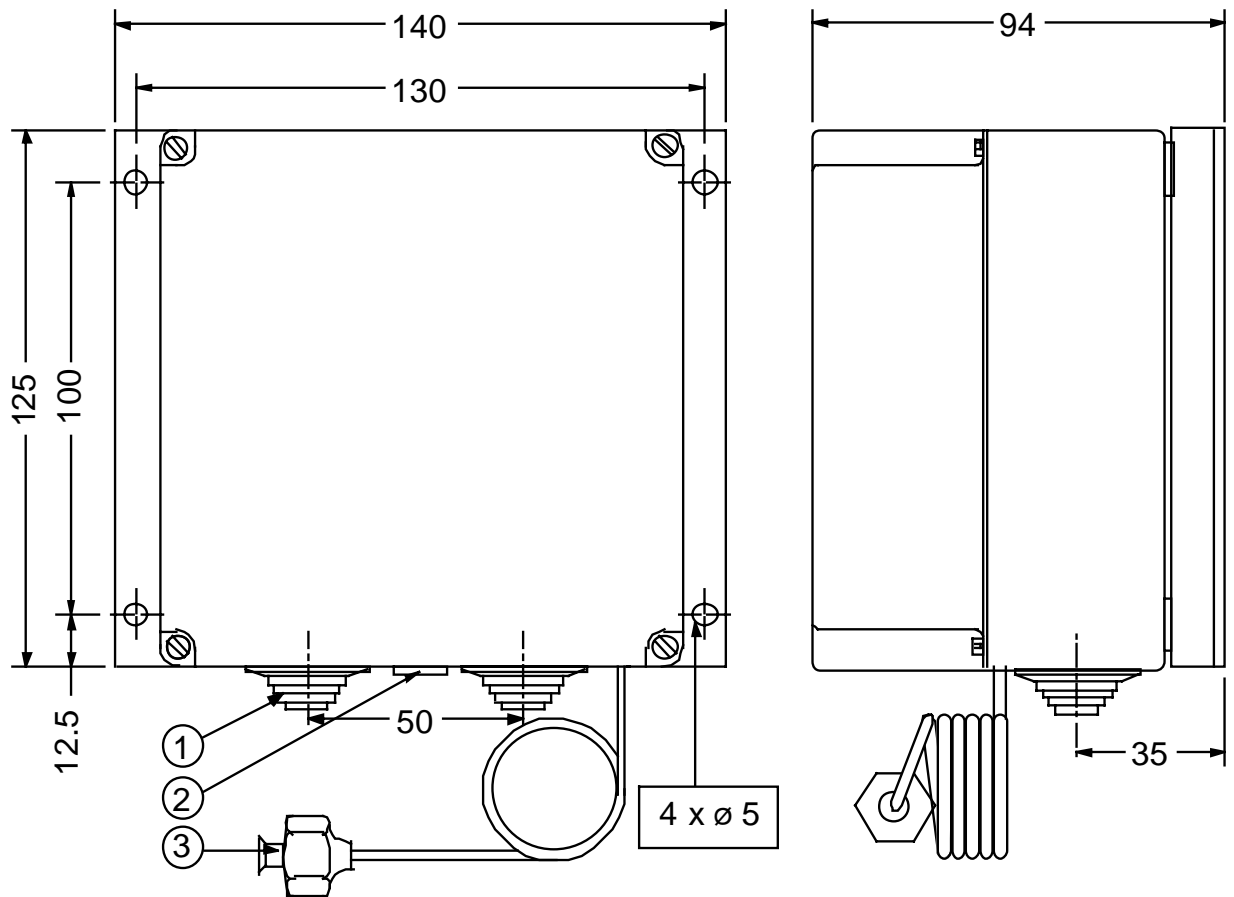

Fig. 5

- 1 cable inlet grommets
- 2 cable inlet heatpump input
- 3 7/16 - 20 UNF flare nut

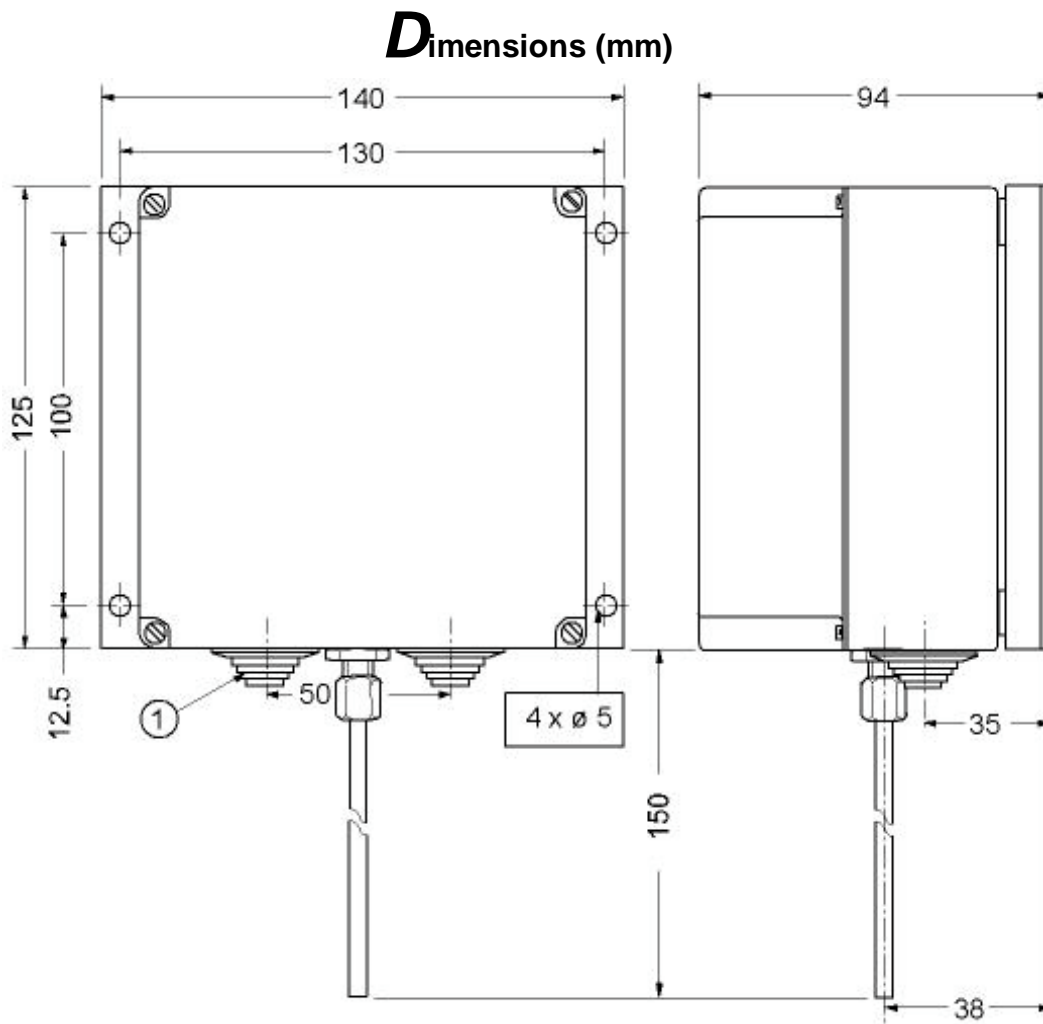

Fig. 10
1 cable inlet grommets

Note

Specifications

Product type	P215SH	
Pressure range	22 to 42 bar 14 to 24 bar 8 to 14 bar	
Maximum overrun pressure	22 to 42 bar = 48 bar 14 to 24 bar = 40 bar 8 to 14 bar = 34 bar	
Pressure connection	style 50 with 90 cm of capillary style 28 with 150 mm tube 6 mm ODM	
Control action	direct	
Maximum output voltage	≥ 95 % of supply voltage	
Maximum current	4 A rms (at maximum voltage output)	
Minimum current	≥ 100 mA	
Power factor (cosφ) motor	≥ 0.6	
Mains supply voltage	230 Vac +10 % / -15 %	
Mains supply frequency	50/60 Hz	
Operating ambient temperature	-20 to +55° C	
Operating /storage ambient humidity.	10 to 98 % R.H. (non-condensing)	
Storage ambient Temp.	-40 to 85 °C	
Min. speed	adjustable from 45 to ≥90 % of supply voltage	
Cut-off point	45 % of supply voltage	
Prop. band	range	22 to 42 bar = 5 ± 2 bar
	range	14 to 24 bar = 4 ± 1 bar
	range	8 to 14 bar = 2.5 ± 0.5 bar
Enclosure	electronic module	IP54
	Material case/cover	polycarbonate
	heatsink	aluminium
	press. connection	90 cm copper capillary with brass flare nut
	Shipping weight	individual pack 1.0 kg
	Residual current motor	in cut-off mode ≤ 15 mA
	Wiring connections	screw terminals 1 mm ² up to 2½ mm ²

The performance specifications are nominal and conform to acceptable industry standards. For applications at conditions beyond these specifications, consult the local Johnson Controls office or representative. Johnson Controls shall not be liable for damages resulting from misapplication or misuse of its products.



Johnson Controls International, Inc.

Headquarters: Milwaukee, WI, USA
 European Headquarters: Westendhof 8, 45143 Essen, Germany
 European Factories: Lomagna (Italy), Leeuwarden (The Netherlands) and Essen (Germany)
 Branch Offices: Principal European Cities.

This document is subject to change

Printed in Europe

Series P215ST

Single Pressure Input Condenser Fan Speed Controllers For Single Phase Motors (incl. built-in RFI suppression filter)

Introduction

These controllers are designed for speed variation of single phase motors, especially for fan speed control on air cooled condensers. Head pressure control of a refrigeration system, through speed variation of the fan on an air-cooled condenser, results in optimum performance throughout the year.

Using a pressure transducer as the input device to the fan speed controller, gives the most direct and fastest response to pressure variations in the refrigerant system. The controller varies the supply voltage to the motor from 45 % to at least 95 % over the proportional band using the phase cutting principle. If the pressure drops below the adjusted setpoint minus the proportional band, the output to the motor is zero volt or the adjusted min. speed setting. This provides speed variation of permanent split capacitor or shaded pole motors which do not draw more than 6 A (rms) full load current.

The controller can be used in non-corrosive refrigerant systems. The motor manufacturer should have approved his product for this speed control principle. It is recommended to confirm with the electric motor manufacturer, that the motor can be used with a controller, using the phase cutting principle for speed variation.



**P215ST
 Condenser Fan Speed Controller**

You can also provide a copy of this P215ST product data sheet to the motor manufacturer/supplier for review.

Feature and Benefits

<input type="checkbox"/> Condenser pressure control by fan speed variation.	Optimum condenser pressure control all the year round. Less noise during colder (night) period.
<input type="checkbox"/> Pressure input.	Direct and fast response to pressure variations. Easy to install
<input type="checkbox"/> Transducers with proven reliability.	More than half a million in use today.
<input type="checkbox"/> Easy accessible setpoint screw.	Setpoint easy adjustable. For use on various non-corrosive refrigerants.
<input type="checkbox"/> Built-in suppression filter.	The control meets the electro magnetic compatibility requirements of the 89/336/EEC directive.
<input type="checkbox"/> Adjustable minimum speed or cut-off selection.	Selection to keep the fan running on (adjusted) minimum rpm or to switch it off.
<input type="checkbox"/> IP54 enclosure.	Can be mounted outdoor.

Note

The P215SH is intended to control equipment under normal operating conditions. Where failure or malfunction of the P215SH could lead to an abnormal operating condition that could cause personal injury or damage to the equipment or other property, other devices (limit or safety controls) or systems (alarm or supervisory systems) intended to warn of or protect against failure or malfunction of the P215SH must be incorporated into and maintained as part of the control system.

**Caution**

Because the P215ST is a single phase control, it may be used only with single-phase motors approved by the manufacturer for speed control applications.

Description

The transducer and electronics are built into an IP54 enclosure.

There are three pressure ranges: 8 to 14 bar
 14 to 24 bar
 22 to 42 bar

Pressure connections are:

style 50 - 90 cm capillary/machined flare with valve depressor

style 51 - 90 cm capillary/machined flare without valve depressor

Installation

The device is provided with a drain hole at the cable inlet side. To maintain the IP54 protection-class the controller must be mounted in a vertical position to assure a permanent drain function. For proper air-circulation there should be a clearance around the controller of at least 10 mm. When mounted inside a cabinet, holes for air circulation should be provided. If the P215ST cannot be mounted vertically, additional limitations apply. The maximum allowable current will be 4A instead of 6A or the maximum allowable ambient temperature is reduced to 40 °C instead of 55 °C.

If a pump-down system is used the pressure connection must be made at the high-pressure side of the system, (before the solenoid valve).

Note

For style 50 and 51 pressure connections two copper sealrings (one spare) are delivered with the control. Each time the pressure connection is removed this sealring has to be replaced.

Wiring (see Fig. 1)

To meet the EMC directive shielded cable has to be used for motor wiring in case the distance between controller and motor is more than 2 meters.

If the distance is less than 2 meters it is allowed to use non-shielded cable.

Non shielded cable may be used if the control and motor are mounted in one frame.

Both sides of the motor cable shield have to be connected to earth. To prevent stray current, the earth connections of the controller, the motor earth connection as well as the cable shield, all have to be connected to one earthing pole.

EMC

The controller does have a built-in suppression filter and meets all required EC directives. Please note that when two or more EMC compliant components are built together the total system may not be compliant. To make the total system compliant is the responsibility of the producer.

Note

Three earth connections are provided except for the 22-42 bar models which have two earth connections.

More motors can be wired in parallel, provided that the total current will not exceed 6 A rms.

Measuring

For measuring amps or volts values a true rms meter should be used.

**Caution**

The P215ST is not equipped with a power switch. Therefore an additional switch to isolate the device should be used in the power supply wiring to the P215ST. Also the P215ST should be externally fused against miswiring or short circuits. Use a thermal/current overload relay with a current rating according to the motor (max. 10 A/slow).

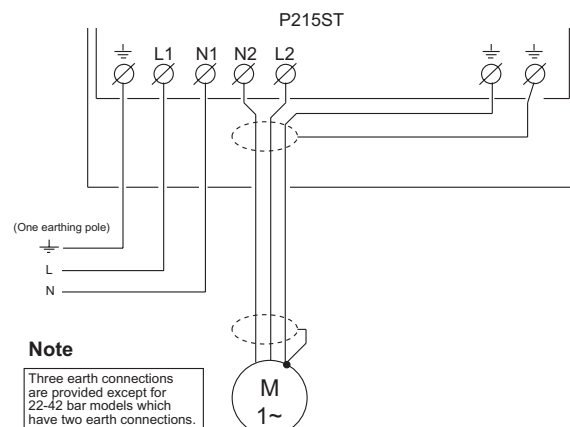
**Fig. 1**

Adjustments

The P215ST gives a control characteristic according to fig. 2.

The control characteristic can be affected by the load and the supply voltage.

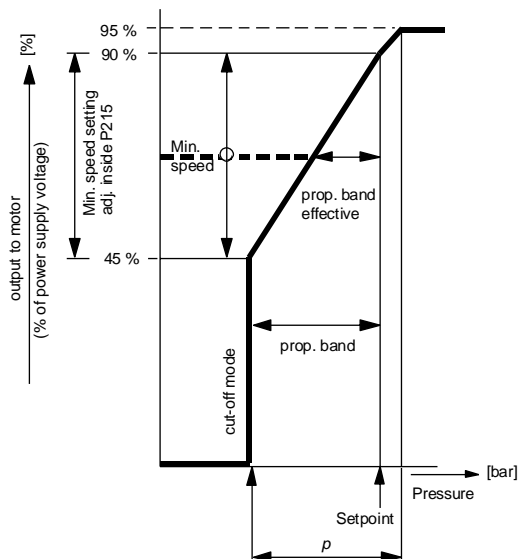

Fig. 2

The proportional band is fixed and defined as the pressure difference between the points where the output values are 45% and 90% of the supply voltage.

	Range in bar		
	8 to 14	14 to 24	22 to 42
Prop. band	2.5 ± 0.5	4 ± 1	5 ± 2
Δ p (max.)	4	6	8

There is a built-in (fixed) hysteresis. This is not indicated in the control characteristic. The hysteresis is included in the prop. band.

Minimum speed setting

The minimum speed voltage setting, to prevent fan speed reduction below desirable levels, can be adjusted between 45 % and 90 % of the line voltage by means of the potentiometer inside the controller (see fig. 3). By turning this potentiometer clockwise into the minimum speed section, the output to the motor stays at a higher level. The minimum speed setting influences the proportional band. A higher setting of the minimum speed results in a smaller proportional band.

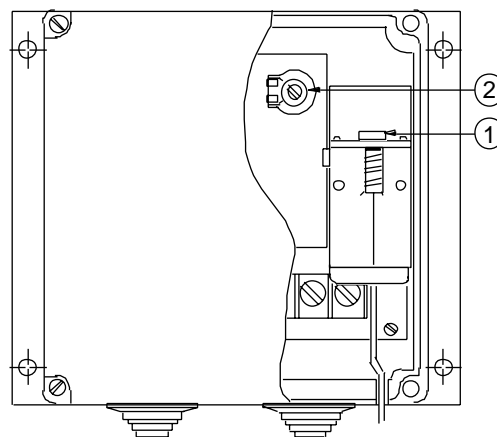

Fig. 3

- 1 Setpoint adjusting screw
- 2 Minimum speed / cut-off potentiometer

Cut-off mode

If minimum speed is not required, turn the potentiometer completely counter-clockwise. The output to the motor drops to 0 V when the pressure decreases below setpoint pressure minus proportional band (fan stops).

Setpoint

The pressure setpoint at which your equipment has to work can be adjusted by the setpoint adjusting screw (see fig. 2 and 3) between 8 to 14, 14 to 24 or 22 to 42 bar.

The setpoint is factory set at:

range 8 to 14 bar	10 bar
range 14 to 24 bar	16 bar
range 22 to 42 bar	30 bar

Repair and replacement

Repair is not possible. In case of an improperly functioning control, please check with your nearest supplier. When contacting the supplier for a replacement you should state the type-model number of the control. This number can be found on the data plate.

Type number selection table

Order nr. (bar)	Range (bar)	Element style	Setting (bar)	Prop. band
P215ST-9100	14 to 24	50	16	4
P215ST-9101	8 to 14	50	10	2.5
P215ST-9102	22 to 42	50	30	5
P215ST-9600	14 to 24	51	16	4

Note: 1 bar = 100 kPa \approx 14.5 psi

Pressure connections

There are two types of pressure connections available.

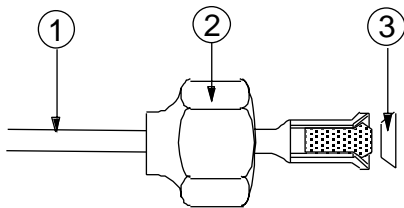

Fig. 4
Style 50 (incl. valve depressor mounted into machined flare)

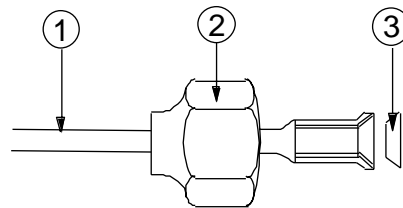

Fig. 5
Style 51 (excl. valve depressor)

1. 90 cm capillary.
2. 7/16 - 20 UNF flare nut.
3. copper sealring

Dimensions (mm)

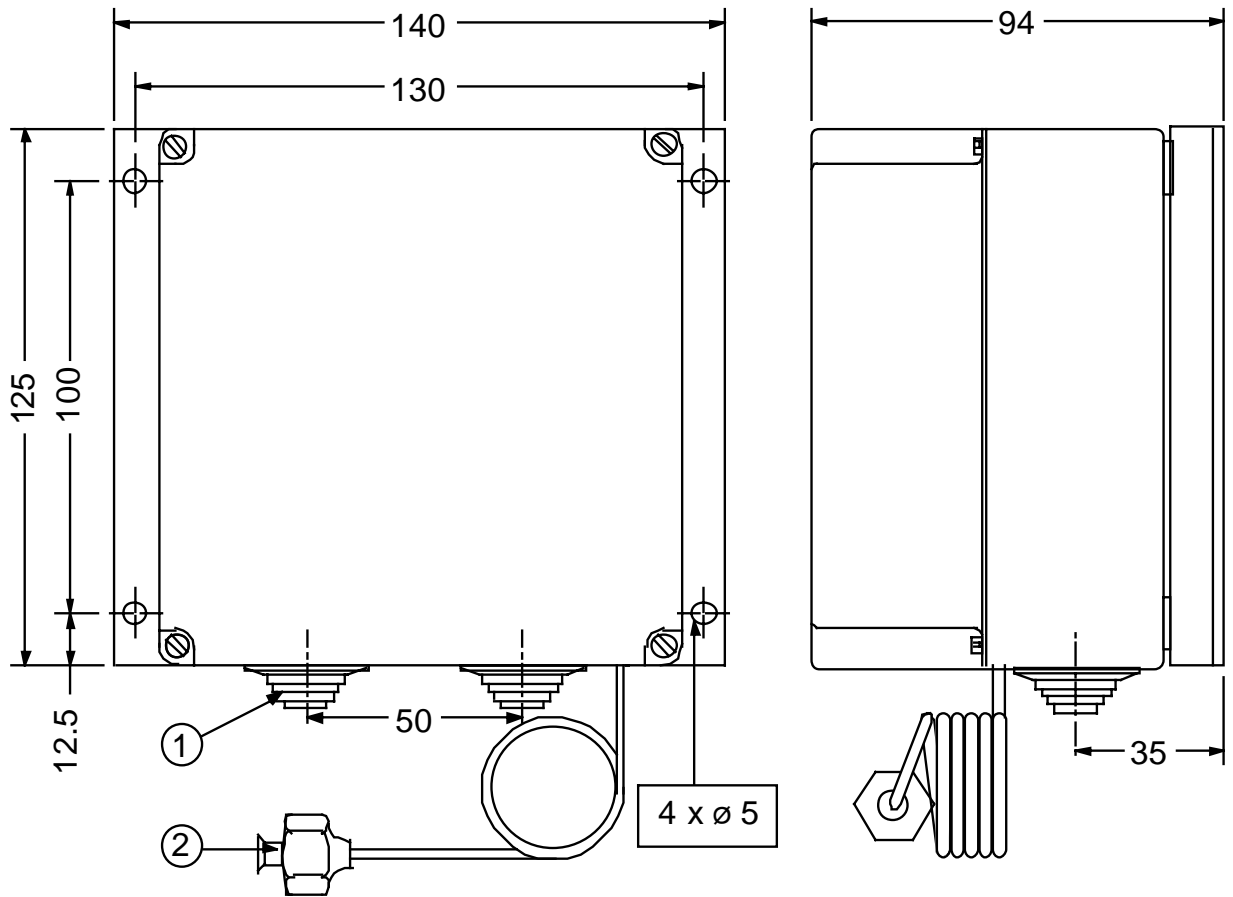

Fig. 6

- 1 cable inlet grommets
- 2 7/16 - 20 UNF flare nut

Specifications

Product type	P215ST	
Pressure range	22 to 42 bar 14 to 24 bar 8 to 14 bar	
Maximum overrun pressure	22 to 42 bar = 48 bar 14 to 24 bar = 40 bar 8 to 14 bar = 34 bar	
Pressure connection	style 50 with 90 cm of capillary style 51 with 90 cm of capillary	
Control action	direct	
Maximum output voltage	≥ 95 % of supply voltage	
Maximum current	6 A rms (at maximum voltage output)	
Minimum current	≥ 100 mA	
Power factor (cosφ) motor	≥ 0.6	
Mains supply voltage	230 Vac +10 % / -15 %	
Mains supply frequency	50/60 Hz	
Operating ambient temperature	-20 to +55° C	
Operating /storage ambient humidity.	10 to 98 % R.H. (non-condensing)	
Storage ambient Temp.	-40 to 85 °C	
Min. speed	adjustable from 45 to ≥90 % of supply voltage	
Cut-off point	45 % of supply voltage	
Prop. band	range	22 to 42 bar = 5 ± 2 bar
	range	14 to 24 bar = 4 ± 1 bar
	range	8 to 14 bar = 2.5 ± 0.5 bar
Enclosure	electronic module	IP54
	Material case/cover	polycarbonate
	heatsink	aluminium
	press. connection	90 cm copper capillary with brass flare nut
	Shipping weight	individual pack 1.0 kg
	Residual current motor	in cut-off mode ≤ 15 mA
	Wiring connections	screw terminals 1 mm ² up to 2½ mm ²

The performance specifications are nominal and conform to acceptable industry standards. For applications at conditions beyond these specifications, consult the local Johnson Controls office or representative. Johnson Controls shall not be liable for damages resulting from misapplication or misuse of its products.



Johnson Controls International, Inc.

Headquarters: Milwaukee, WI, USA
 European Headquarters: Westendhof 8, 45143 Essen, Germany
 European Factories: Lomagna (Italy), Leeuwarden (The Netherlands) and Essen (Germany)
 Branch Offices: Principal European Cities.

This document is subject to change

Printed in Europe

Series P215DP

Single/Dual Pressure Input Condenser Fan Speed Controllers For Single Phase Motors (incl. built-in RFI suppression filter)

Introduction

These controllers are designed for speed variation of single phase motors, especially for fan speed control on air cooled condensers.

Head pressure control of a refrigeration system, through speed variation of the fan on an air-cooled condenser, results in optimum performance throughout the year.

Using a pressure transducer as the input device to the fan speed controller, gives the most direct and fastest response to pressure variations in the refrigerant system. The controller varies the supply voltage to the motor from 45 % to at least 95 % over the proportional band using the phase cutting principle.

If the pressure drops below the adjusted setpoint minus the proportional band, the output to the motor is zero volt or the adjusted min. speed setting. This provides speed variation of permanent split capacitor or shaded pole motors which do not draw more than 8 A (rms) full load current.

The controller used for dual pressure input varies the fan speed by directly sensing the pressure changes of two separate refrigerant circuits.

The setpoint of each pressure transducer can be separately adjusted. The controller selects the input with the greatest cooling demand to control the fan speed. The transducers can be used in non-corrosive refrigerant systems.



**P215DP
Condenser Fan Speed Controller**

The motor manufacturer should have approved his product for this speed control principle. It is recommended to confirm with the electric motor manufacturer, that the motor can be used with a controller, using the phase cutting principle for speed variation.

You can also provide a copy of this P215DP product data sheet to the motor manufacturer/supplier for review.

Feature and Benefits

<input type="checkbox"/> Condenser pressure control by fan speed variation.	Optimum condenser pressure control all the year round. Less noise during colder (night) period.
<input type="checkbox"/> Pressure input.	Direct and fast response to pressure variations. Easy to install
<input type="checkbox"/> Transducers with proven reliability.	More than half a million in use today.
<input type="checkbox"/> Easy accessible setpoint screw.	Setpoint easy adjustable. For use on various non-corrosive refrigerants.
<input type="checkbox"/> Built-in suppression filter.	The control meets the electro magnetic compatibility requirements of the 89/336/EEC directive.
<input type="checkbox"/> Adjustable minimum speed or cut-off selection.	Selection to keep the fan running on (adjusted) minimum rpm or to switch it off.
<input type="checkbox"/> Dual input possibility.	Can be used on condensers with two separate refrigerant circuits.
<input type="checkbox"/> IP54 enclosure.	Can be mounted outdoor.

Note

These controls are designed for use only as operating controls. Where an operating control failure would result in personal injury or loss of property it is the responsibility of the installer to add devices or systems that protect against, or warn of, control failure.

Caution

The P215DP is intended to control equipment under normal operating conditions. Where failure or malfunction of the P215DP could lead to an abnormal operating condition that could cause personal injury or damage to the equipment or other property, other devices (limit or safety controls) or systems (alarm or supervisory systems) intended to warn of or protect against failure or malfunction of the P215DP must be incorporated into and maintained as part of the control system.

Description

The P215DP can be used for single or dual pressure input. For single input the transducer and the electronics are built in an IP54 enclosure.

For dual input a separate P35AC pressure transducer (IP20) must be ordered (see type number selection table).

In the case of dual input the controller selects the input with the greatest cooling demand to control the fan speed.

There are three pressure ranges: 8 to 14 bar
 14 to 24 bar
 22 to 42 bar

Pressure connections are:

style 50 - 90 cm capillary/machined flare with valve depressor

style 51 - 90 cm capillary/machined flare without valve depressor

style 28 - 15 cm brazing tube 6 mm ODM

Installation

The device is provided with a drain hole at the cable inlet side. To maintain the IP54 protection-class the controller must be mounted in a vertical position to assure a permanent drain function. For proper air-circulation there should be a clearance around the controller of at least 10 mm. When mounted inside a cabinet, holes for air circulation should be provided. If the P215DP cannot be mounted vertically, additional limitations apply. The maximum allowable current will be 6A instead of 8A or the maximum allowable ambient temperature is reduced to 40 °C instead of 55 °C. For dual input the second transducer can be installed in any convenient location, provided that the ambient conditions are suitable for IP20 enclosure. Enclosed mounting bracket can be used. If a pump-down system is used the pressure connection must be made at the high-pressure side of the system, (before the solenoid valve).

Note

For style 50 and 51 pressure connections two copper sealings (one spare) are delivered with the control. Each time the pressure connection is removed this sealing has to be replaced.

Wiring (see Fig. 1)

To meet the EMC directive shielded cable has to be used for motor wiring in case the distance between controller and motor is more than 2 meters. If the distance is less than 2 meters it is allowed to use non-shielded cable.

Non shielded cable may be used if the control and motor are mounted in one frame.

Both sides of the shield (motor and second pressure transducer wiring) have to be connected to earth. To prevent stray current, the earth connections of the transducer, the controller, the motor earth connection as well as the cable shield, all have to be connected to one earthing pole.

EMC

The controller does have a built-in suppression filter and meets all required EC directives. Please note that when two or more EMC compliant components are built together the total system may not be compliant. To make the total system compliant is the responsibility of the producer.

Note

Three earth connections are provided except for the 22-42 bar models which have two earth connections.

More motors can be wired in parallel, provided that the total current will not exceed 8 A rms.

Dual input connection

The second input can be connected as indicated in fig. 1.

If the distance between the transducer and the controller exceeds two metres shielded cable has to be used (The shield can be connected under the screw used to connect the transducer to the mounting bracket).

Enclosed quick connector plug can be used to connect wires to the transducer.

Caution

The enclosed quick connector plug is especially designed (special terminal numbering) for this control and should not be used for other purposes. Take care to connect the correct wires when the original connector is replaced by a non Johnson Control type.

Caution

There will be line voltage on the wiring between the second input pressure transducer and the P215DP.

Measuring

For measuring amps or volts values a true rms meter should be used.

Caution

The P215DP is not equipped with a power switch. Therefore an additional switch to isolate the device should be used in the power supply wiring to the P215DP. Also the P215DP should be externally fused against miswiring or short circuits. Use a thermal/current overload relay with a current rating according to the motor (max. 16 A/slow).

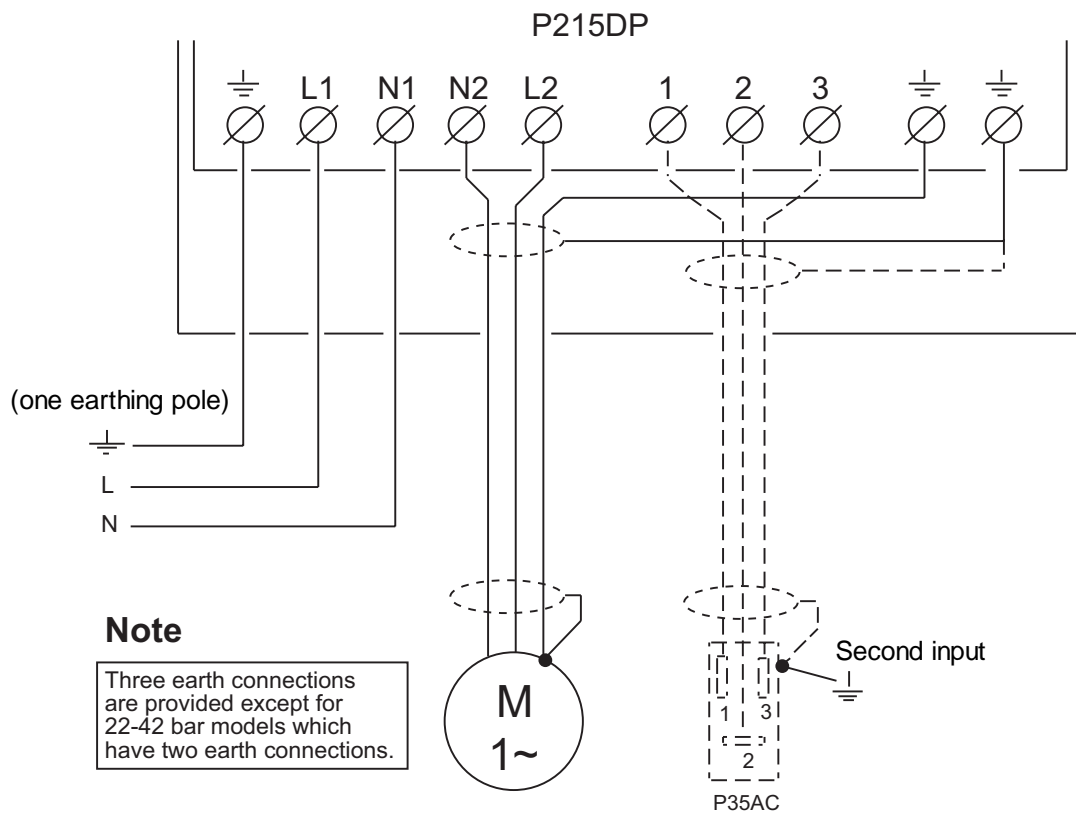

Fig. 1

Adjustments

The P215DP gives a control characteristic according to fig. 2.

The control characteristic can be affected by the load and the supply voltage.

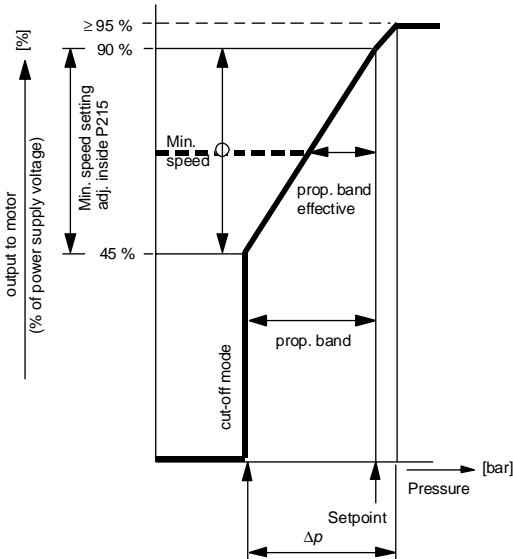

Fig .2

The proportional band is fixed and defined as the pressure difference between the points where the output values are 45% and 90% of the supply voltage.

	Range in bar		
	8 to 14	14 to 24	22 to 42
Prop. band	2.5 ± 0.5	4 ± 1	5 ± 2
Δ p (max.)	4	6	8

There is a built-in (fixed) hysteresis. This is not indicated in the control characteristic. The hysteresis is included in the prop. band.

Minimum speed setting

The minimum speed voltage setting, to prevent fan speed reduction below desirable levels, can be adjusted between 45 % and 90 % of the line voltage by means of the potentiometer inside the controller (see fig. 3). By turning this potentiometer clockwise into the minimum speed section, the output to the motor stays at a higher level. The minimum speed setting influences the proportional band. A higher setting of the minimum speed results in a smaller proportional band.

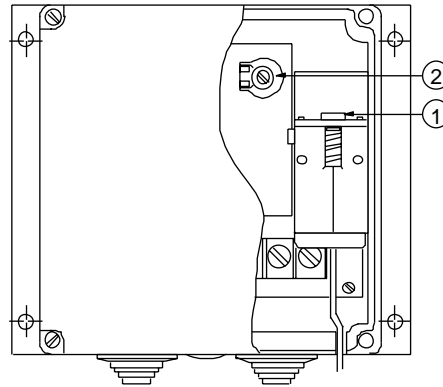

Fig. 3

- 1 Setpoint adjusting screw
- 2 Minimum speed / cut-off potentiometer

Cut-off mode

If minimum speed is not required, turn the potentiometer completely counter-clockwise. The output to the motor drops to 0 V when the pressure decreases below setpoint pressure minus proportional band. (fan stops.)

Setpoint

The pressure setpoint at which your equipment has to work can be adjusted by the setpoint adjusting screw (see fig. 2 and 3) between 8 to 14, 14 to 24 or 22 to 42 bar.

The setpoint is factory set at:

range 8 to 14 bar	10 bar
range 14 to 24 bar	16 bar
range 22 to 42 bar	30 bar

Note

If a second input is used and it is necessary to make setpoint adjustments on the P215DP care should be taken that the additional transducer does not affect the output voltage of the controller while adjustment is being made on the other transducer. The easiest way to do this is to set the built-in transducer to high pressure (+). Then adjust the second transducer to the required value. After adjusting disconnect the blue connector. Then set the built-in transducer to the required value. Reconnect the blue connector of the second transducer.

Repair and replacement

Repair is not possible. In case of an improperly functioning control, please check with your nearest supplier. When contacting the supplier for a replacement you should state the type-model number of the control. This number can be found on the data plate.

Type number selection table

Order nr.	Range (bar)	Element style	Setting (bar)	Prop. band (bar)	Second input pressure transducer	See Figure
P215DP-9100	14 to 24	50	16	4	P35AC-9100	7A
P215DP-9101	8 to 14	50	10	2.5	P35AC-9101	7A
P215DP-9102	22 to 42	50	30	5	P35AC-9512	7B
P215DP-9600	14 to 24	51	16	4	P35AC-9507	7A
P215DP-9601	8 to 14	51	10	2.5	P35AC-9508	7A
P215DP-9800	14 to 24	28	16	4	P35AC-9100	7A

All models are delivered with a single pressure transducer A second pressure transducer can be ordered. For type number see type number selection table

Note: 1 bar = 100 kPa ≈ 14.5 psi

Pressure connections

There are two types of pressure connections available.

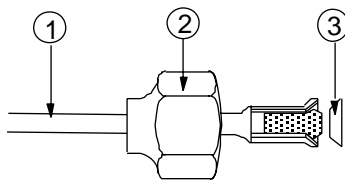

Fig. 4
Style 50 (incl. valve depressor mounted into machined flare)

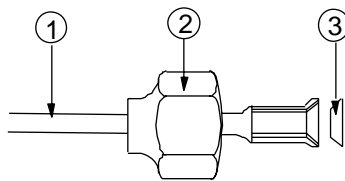

Fig. 5
Style 51 (excl. valve depressor)

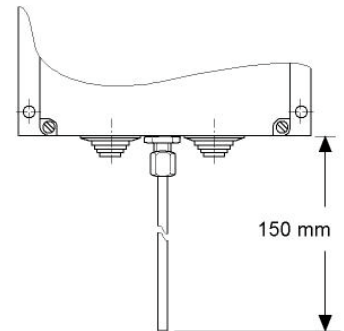

Fig. 6
Style 28 Braze connection
6 mm ODM

1. 90 cm capillary. 2. 7/16 - 20 UNF flare nut. 3. copper searling

Dimensions (mm)

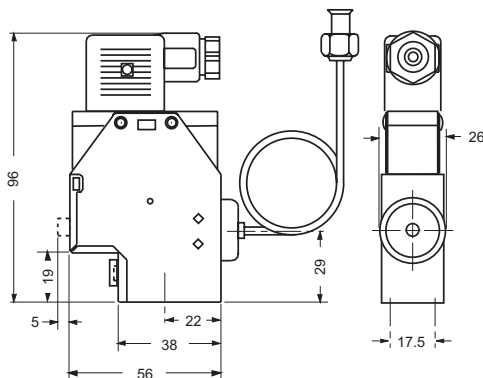

Fig. 7A
P35AC

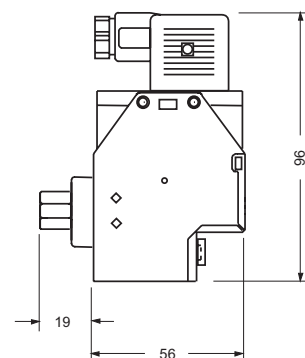

Fig. 7B
P35A

Dimensions (mm)

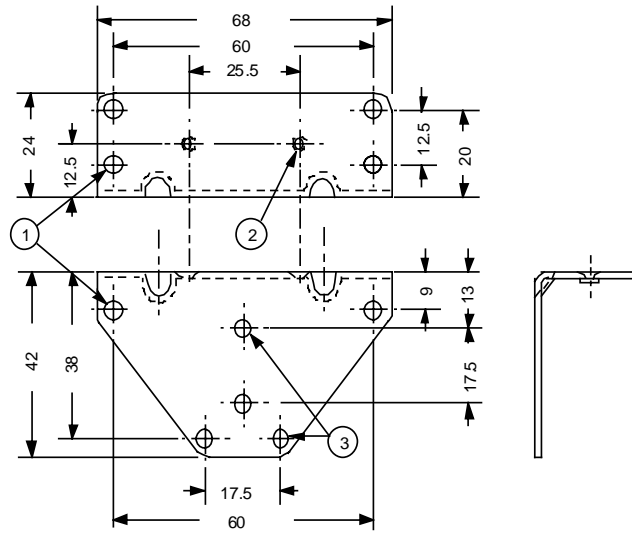

Fig. 8
Mounting Bracket 210-25

- 1 Mounting hole \varnothing 4 mm
- 2 Extruded 6-32 UNC thread
- 3 Mounting hole for P35AC \varnothing 4 mm

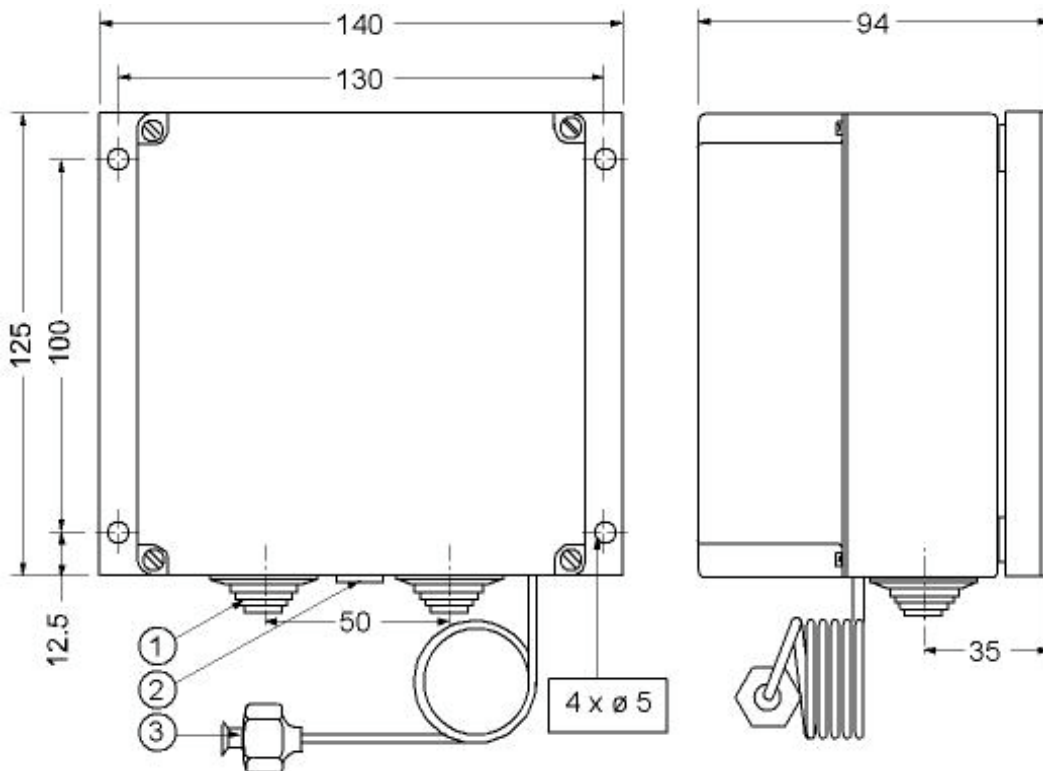

Fig. 9

- 1 cable inlet grommets
- 2 cable inlet second input transducer
- 3 7/16 - 20 UNF flare nut

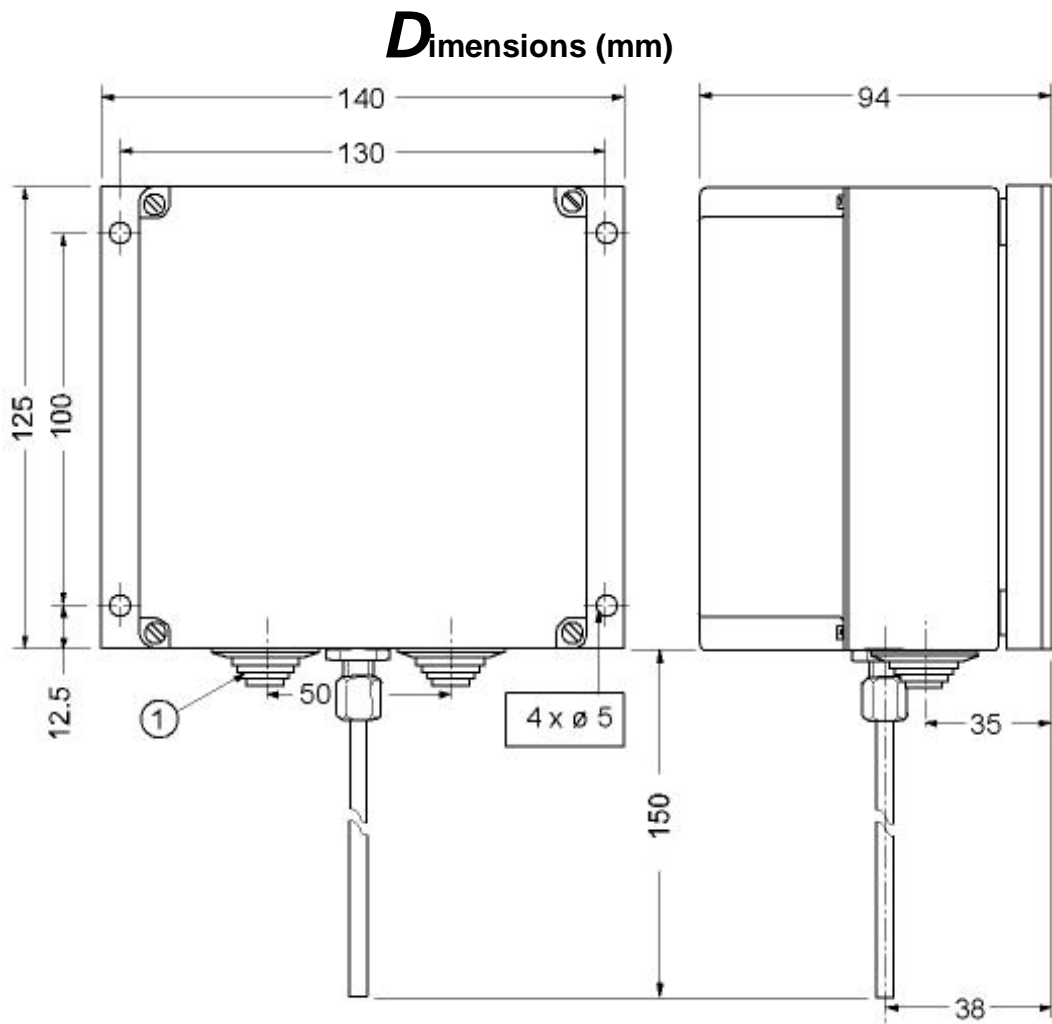

Fig. 10
1 cable inlet grommets

Specifications

Product type	P215DP	
Pressure range	22 to 42 bar 14 to 24 bar 8 to 14 bar	
Maximum overrun pressure	22 to 42 bar = 48 bar 14 to 24 bar = 40 bar 8 to 14 bar = 34 bar	
Pressure connection	style 50 with 90 cm of capillary style 51 with 90 cm of capillary style 28 with 150 mm tube 6mm ODM	
Control action	direct	
Maximum output voltage	≥ 95 % of supply voltage	
Maximum current	8 A rms (at maximum voltage output)	
Minimum current	≥ 100 mA	
Power factor (cosφ) motor	≥ 0.6	
Mains supply voltage	230 Vac +10 % / -15 %	
Mains supply frequency	50/60 Hz	
Operating ambient temperature	-20 to +55° C	
Operating /storage ambient humidity.	10 to 98 % R.H. (non-condensing)	
Storage ambient Temp.	-40 to 85 °C	
Min. speed	adjustable from 45 to ≥90 % of supply voltage	
Cut-off point	45 % of supply voltage	
Prop. band	range	22 to 42 bar = 5 ± 2 bar
	range	14 to 24 bar = 4 ± 1 bar
	range	8 to 14 bar = 2.5 ± 0.5 bar
Enclosure	IP54	
additional pressure transducer	IP20	
Material case/cover	polycarbonate	
heatsink	aluminium	
press. connection	90 cm copper capillary with brass flare nut	
Shipping weight	individual pack	1.0 kg
Residual current motor	in cut-off mode ≤ 15 mA	
Wiring connections	screw terminals 1 mm ² up to 2½ mm ²	
additional P35AC	screw terminals 1 mm ² up to 1½ mm ²	

The performance specifications are nominal and conform to acceptable industry standards. For applications at conditions beyond these specifications, consult the local Johnson Controls office or representative. Johnson Controls shall not be liable for damages resulting from misapplication or misuse of its products.



Johnson Controls International, Inc.

Headquarters: Milwaukee, WI, USA
 European Headquarters: Westendhof 8, 45143 Essen, Germany
 European Factories: Lomagna (Italy), Leeuwarden (The Netherlands) and Essen (Germany)
 Branch Offices: Principal European Cities.

This document is subject to change

Printed in Europe

Series P255MM/ML

Single/Dual Pressure Input Condenser Fan Speed Controllers For Three Phase Motors (incl. built-in RFI suppression filter)

Introduction

These controllers are designed for speed variation of 3-phase motors, especially for fan speed control on air cooled condensers.

Head pressure control of a refrigeration system, through speed variation of the fan on an air-cooled condenser, results in optimum performance throughout the year.

Using a pressure transducer as the input device to the fan speed controller, gives the most direct and fastest response to pressure variations in the refrigerant system. The controller varies the supply voltage to the motor from 30% to at least 96% over the proportional band using the phase cutting principle. Motors that will be controlled by the P255 should not draw more than 5 A per phase.

The controller used for dual pressure input varies the fan speed by directly sensing the pressure changes of two separate refrigerant circuits. Each pressure transducer can be separately adjusted at a setpoint between 8 to 42 bar. The controller selects the input with the greatest cooling demand to control the fan speed. The transducers can be used in non-corrosive refrigerant systems.



**P255MM/ML
Condenser Fan Speed Controller**

Feature and Benefits

<input type="checkbox"/> Condenser pressure control by fan speed variation.	Optimum condenser pressure control all the year round.
<input type="checkbox"/> Pressure input.	Direct and fast response to pressure variations.
<input type="checkbox"/> Dual input possibility.	Can be used on condensers with two separate refrigerant circuits.
<input type="checkbox"/> Transducers with proven reliability.	More than half a million in use today.
<input type="checkbox"/> Easy accessible setpoint screw.	Setpoint easy adjustable. For use on various refrigerants.
<input type="checkbox"/> Built-in suppression filter.	The control meets the electro magnetic compatibility requirements of the 89/336/EEC directive.
<input type="checkbox"/> Minimum speed or cut-off selection.	Selection to keep the fan running on minimum speed or to switch it off.
<input type="checkbox"/> Adjustable minimum speed or cut-off. Adjustable maximum speed limit. Proportional band adjustment.	Maximum flexibility to adjust cooling capacity and/or to get the best motor performance.
<input type="checkbox"/> Contact input to force output to max. or off.	Control interrupt possibility.
<input type="checkbox"/> Allows connection in both "Star" and "Delta" configurations.	3 wire motor connection for both "Star" and "Delta" connection.
<input type="checkbox"/> Motor speed action can be reversed by interchanging only two wires.	Easy change over from direct to reverse control action
<input type="checkbox"/> Adjustable hysteresis in cut-off mode.	Easy motor start by adjustable start voltage.
<input type="checkbox"/> IP54 enclosure for electronic module.	Can be mounted outdoor.
<input type="checkbox"/> Cosφ motor adjustment.	Optimum control and motor performance.

Electric motor selection

Care must be taken when selecting an electric motor as the controller uses the phase cutting principle for variation of motor speed. This will cause additional heat generation in the stator (motor winding) and the rotor of the motor, especially at medium speed.

At medium speed the current to the motor will be at its highest level whereas the cooling of the motor has already substantially decreased. Motors that are designed to handle this extra heat generation are preferred. The use of thermal motor winding protection switches is advised. Often (depending on the total application conditions) a class F motor should be used to handle the temperature increase. Motors with lower temperature classification might be interrupted by the temperature protection switches, which are embedded in the motor windings. Finally, the motor should have bearings that provide sufficient lubrication at lower RPM and possibly increased shaft temperatures.

It is recommended to confirm with the electric motor manufacturer, that the motor can be used with a controller, using the phase cutting principle for speed variation. You can also provide a copy of this P255 product data sheet to the motor manufacturer/supplier for review.

Note

At lower speeds (between 50% and 75% of rpm mentioned on the motor data plate), depending on motortype and load, the max. current can become higher than I nominal of the motor. In case the max. current increases above 5 Amp. the max. allowed ambient temperature will become lower as indicated in the diagram (see fig. 1).

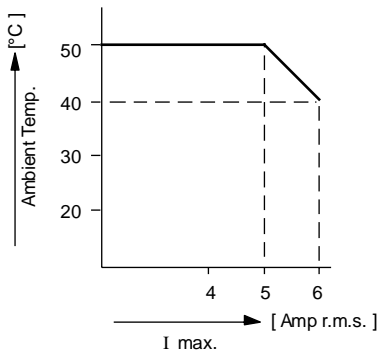

Fig. 1

Note

The P255MM/ML is intended to control equipment under normal operating conditions. Where failure or malfunction of the P255MM/ML could lead to an abnormal operating condition that could cause personal injury or damage to the equipment or other property, other devices (limit or safety controls) or systems (alarm or supervisory systems) intended to warn of or protect against failure or malfunction of the P255MM/ML must be incorporated into and maintained as part of the control system.

Description

The P255 consists of an electronic module type P38AD and a pressure transducer type P35AC.

The P38AD can be used for single or dual pressure input. For dual input a separate P35AC pressure transducer must be ordered (see type number selection table). In the case of dual input the controller selects the input with the greatest cooling demand to control the fan speed.

There are three pressure ranges:

8 to 14 bar
14 to 24 bar
22 to 42 bar

Installation

Mount the electronic module in a vertical position. The electronic module is provided with spacers to create at least 10 mm distance between the mounting surface and the heatsink. For proper air-circulation there should be a clearance around the controller of at least 50 mm. When mounted inside a cabinet, holes for air circulation should be provided. If the P255 cannot be mounted vertically, additional limitations apply. The maximum allowable current will be 3.5 A instead of 5 A or the maximum allowable ambient temperature is reduced to 35°C instead of 50°C. The transducers can be installed in any convenient location, provided that the ambient conditions are suitable for IP20 enclosure.

Enclosed mounting bracket can be used.

Note

For style 50 pressure connections two copper seal rings (one spare) are delivered with the control. Each time the pressure connection is removed this seal ring has to be replaced.

Wiring motor

The motor can be wired in Star or Delta. To meet the EMC directive shielded cable has to be used for motor wiring in case the distance between controller and motor is more than 2 meters. If the distance is less than 2 meters it is allowed to use non-shielded cable. (see fig. 2).

Non shielded cable may be used if the control and motor are mounted in one frame.

Both sides of the shield have to be connected. To prevent stray current, the two earth connections of the controller, the motor earth connection as well as the cable shield, all have to be connected to one earthing pole (see fig. 2).

More motors can be wired in parallel, provided that the total current will not exceed 5 A rms.

EMC

The controller does have a built-in suppression filter and meets all required EC directives. Please note that when two or more EMC compliant components are built together the total system may not be compliant. To make the total system compliant is the responsibility of the producer

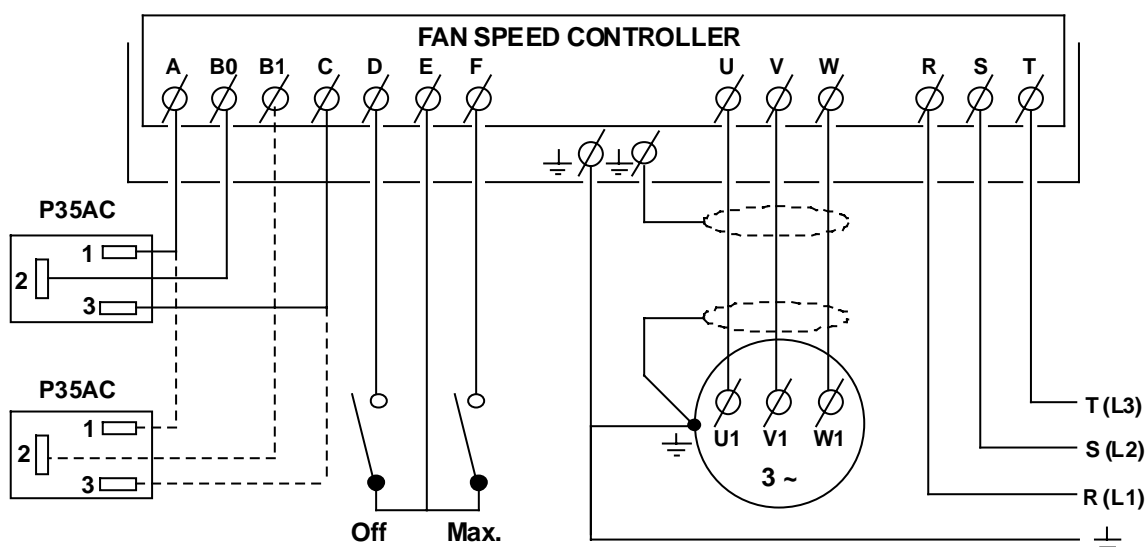

Fig. 2

Wiring pressure transducer(s)

(see fig.2)

There is low voltage (12 V) on wiring between transducer(s) and electronic module.

Enclosed quick connector plug(s) can be used to connect wires to the transducer(s).

! Caution

The enclosed quick connector plug(s) is especially designed (special terminal numbering) for this control and should not be used for other purposes. Take care to connect the correct wires when the original connector is replaced by a non Johnson Controls type.

Control action (direct/reverse)

The transducer wiring as shown in fig. 2 is for direct action (output voltage increases at increasing pressure). If reverse action is desired, this can be obtained by interchanging wires at terminals A and C of the electronic module.

Max. speed / fan off

A potential free contact can be connected to the P255 to force the output to maximum (output \geq 96% of supply voltage) or to switch the fan off (see fig. 2).

Terminal E is the common. If E is connected to F the fan goes to max. speed. If E is connected to D the fan is switched off.

Measuring

For measuring amps or volts values a true rms meter should be used.

! Caution

The P255 is not equipped with a power switch. Therefore an additional switch to isolate the device should be used in the power supply wiring to the P255.

For motor protection the use of thermal motor winding protection switches is preferred. If a thermal/ current overload relay is used the max. current (between 50% and 75% of the speed) should be measured to set the overload relay. A larger difference between I nom. and I max. results in an insufficient motor protection.

Fuses

Controller damage, caused by too high load, will be prevented /limited by the built-in 10A glass fuses. In case of malfunctioning of the controller these fuses should be checked first.

For protection of the main power wiring external 400V NEOZED or 500V DIAZET fuses can be used. The required fuse amperage depends on the used wiring. See below table.

1 mm ²	6 Amp
1.5 mm ²	10 Amp
2.5 mm ²	16 Amp

Selection 50/60 Hz (see fig.4)

The control will be delivered for use on 50 Hz supply frequency. For 60 Hz selection the selector switch position must be changed to 60 Hz.

Adjustments

The electronic module P38AD gives a control characteristic according to fig. 3. The control characteristic is affected by the load and the supply voltage.

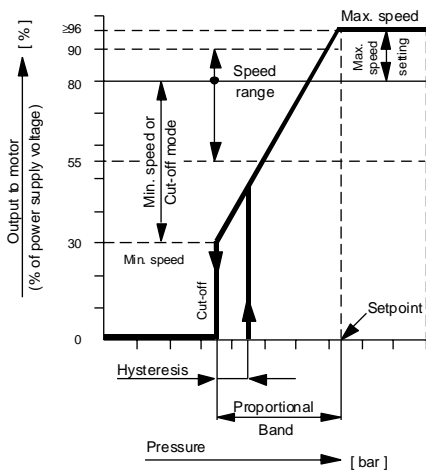

Fig.3 Factory adjusted characteristic

Adjustable settings: (see Fig. 4 and 6)

- Setpoint 8 to 14 ,14 to 24 or 22 to 42 bar
- Speed range 55 to 90% of supply voltage
- Max. speed 55 to $\geq 96\%$ of supply voltage
- Min. speed 30 to 90% of supply voltage
- Cut-off 30 to 90% of supply voltage
- Prop. band 0.5 to 4 bar (8 to 14 bar range)
1 to 6 bar (14 to 24 bar range)
1 to 8 bar (22 to 42 bar range)
- Hysteresis 5 to 70% of adj. prop. band
- Cos ϕ 0.6 to 1

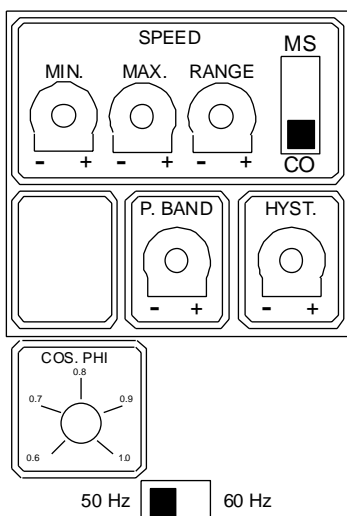

Fig.4

Factory settings

- Setpoint range 8 to 14 bar - 10 bar
range 14 to 24 bar - 16 bar
range 22 to 42 bar - 30 bar
- Speed range 80%
- Max. speed $\geq 96\%$
- Cut-off 30%
- Prop. band range 8 to 14 bar - 4 bar
range 14 to 24 bar - 6 bar
range 22 to 42 bar - 8 bar
- Hysteresis 5%
- Cos ϕ 0.8
- MS/CO switch position CO
- 50/60 Hz switch position 50 Hz

The controller will be delivered with these settings..

Setpoint

The pressure setpoint (point A) at which the control delivers maximum output can be adjusted by the range screw R (fig. 5) on the pressure transducer.

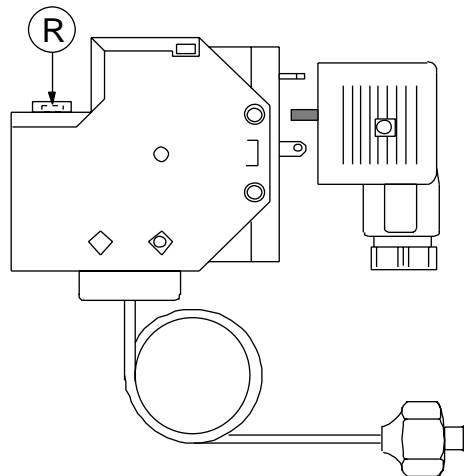

Fig. 5

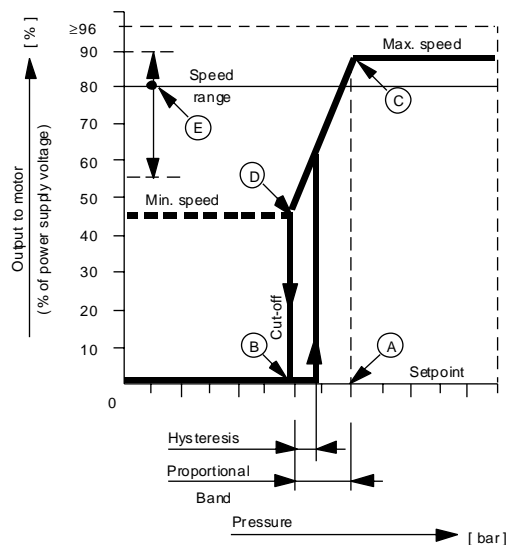

Fig. 6

Maximum speed limit

It is possible to adjust a maximum speed limit (point C). This means that the output to the motor will not increase above the adjusted setting. The maximum speed limit can be adjusted with potentiometer "MAX." inside the electronic module (see fig. 4). The maximum output voltage to the motor is adjustable from the adjusted speed range line up to $\geq 96\%$ of the power supply voltage.

Minimum speed

The minimum speed voltage setting (point D), to prevent fan speed reduction below desirable levels, can be adjusted from 30% of the power supply voltage up to the adjusted speed range line by means of potentiometer "MIN." inside the electronic module and selector switch MS/CO set to minimum speed mode MS (see fig. 4).

Speed range line

The max. speed adjustment is independent from the min. speed adjustment. To prevent that the min. speed is set to a higher value than max. speed (no output any more) the "speed range line" is introduced. This (imaginary) line divides the output characteristic into an upper part and lower part.

The maximum speed can be adjusted in the upper part (from $\geq 96\%$ down to the adjusted speed range value). The minimum speed/cut-off can be adjusted in the lower part (from 30% up to the adjusted speed range value). The speed range line (point E) can be adjusted with the speed "RANGE" potentiometer (see fig. 4) from 55% to 90% of the power supply voltage.

Cut-off mode

In the cut-off mode the output to the motor will drop to zero if the pressure decreases below point B. The fan stops. The cut-off can be adjusted from 30% of the power supply voltage up to the adjusted speed range line by means of potentiometer "MIN." inside the electronic module and the selector switch MS/CO set to cut-off mode CO (see fig. 4).

Proportional band

The proportional band is the difference between the pressure at which the output is 0 V (point B) or the minimum speed voltage (point D) and the pressure at setpoint (point A). The proportional band is adjustable with potentiometer "P-BAND" inside the electronic module. (see fig. 4)

Hysteresis

A running fan can be controlled to a low speed. Sometimes it gives trouble starting at this low speed. Therefore it is possible to adjust the hysteresis which means the motor starts at a higher voltage. The hysteresis can be adjusted by potentiometer "HYST." between 5% and 70% of the adjusted proportional band (see fig. 4).

Cos ϕ

On the motor data plate the $\cos\phi$ of the motor is indicated. To get the most optimal control the "COSPHI" potmeter (see fig. 4) must be set to this value. If $\cos\phi$ is not known the potmeter can be set to 0.8

Repair and replacement

Repair is not possible. In case of an improperly functioning control, please check with your nearest supplier. When contacting the supplier for a replacement you should state the type-model number of the control. This number can be found on the data plate.

Type number selection and replacement table

Order nr.	Range (bar)	Element style	Supply voltage	Transducer type	See Fig.	Electronic module type
P255ML-9200	14 to 24	47	230 V - 3 phase	P35AC-9200	13B	P38AD-9101
P255MM-9100	14 to 24	45A	400 V - 3 phase	P35AC-9106	13A	P38AD-9100
P255MM-9101	8 to 14	45A	400 V - 3 phase	P35AC-9105	13A	P38AD-9100
P255MM-9200	14 to 24	47	400 V - 3 phase	P35AC-9200	13B	P38AD-9100
P255MM-9201	8 to 14	47	400 V - 3 phase	P35AC-9201	13B	P38AD-9100
P255MM-9500	14 to 24	50	400 V - 3 phase	P35AC-9506	13A	P38AD-9100
P255MM-9501	8 to 14	50	400 V - 3 phase	P35AC-9505	13A	P38AD-9100
P255MM-9503	22 to 42	50	400 V - 3 phase	P35AC-9511	13C	P38AD-9100
P255MM-9600	14 to 24	13	400 V - 3 phase	P35AC-9604	13A	P38AD-9100
P255MM-9601	8 to 14	13	400 V - 3 phase	P35AC-9603	13A	P38AD-9100

note: 1 bar = 100 kPa ≈ 14.5 psi

All models are delivered with a single pressure transducer. A second pressure transducer can be ordered. For type number see type number selection table.

Pressure connections

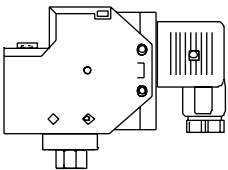

Fig. 7

Style 47 direct mount
7/16 - 20 UNF female
(incl. valve depressor)

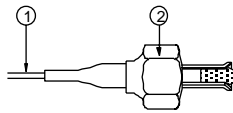

Fig. 8

Style 45A (incl. valve depressor mounted into capillary flare section)

1. 90 cm capillary.

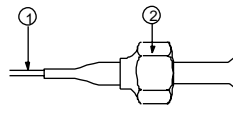

Fig. 9

Style 13 (without valve depressor)

2. 7/16 - 20 UNF flare nut.

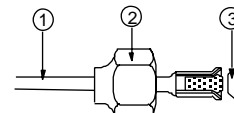

Fig. 10

Style 50 (incl. valve depressor mounted into machined flare)

3. copper seal ring

- 1 Mounting hole \varnothing 4 mm
- 2 Extruded 6-32 UNC thread
- 3 Mounting hole for P35AC \varnothing 4 mm

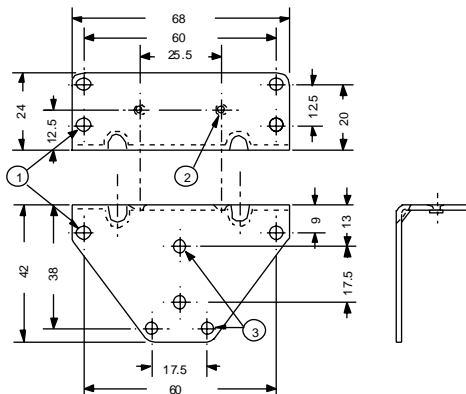

Fig. 11
Mounting Bracket 210-25

Dimensions (mm)

P38AD

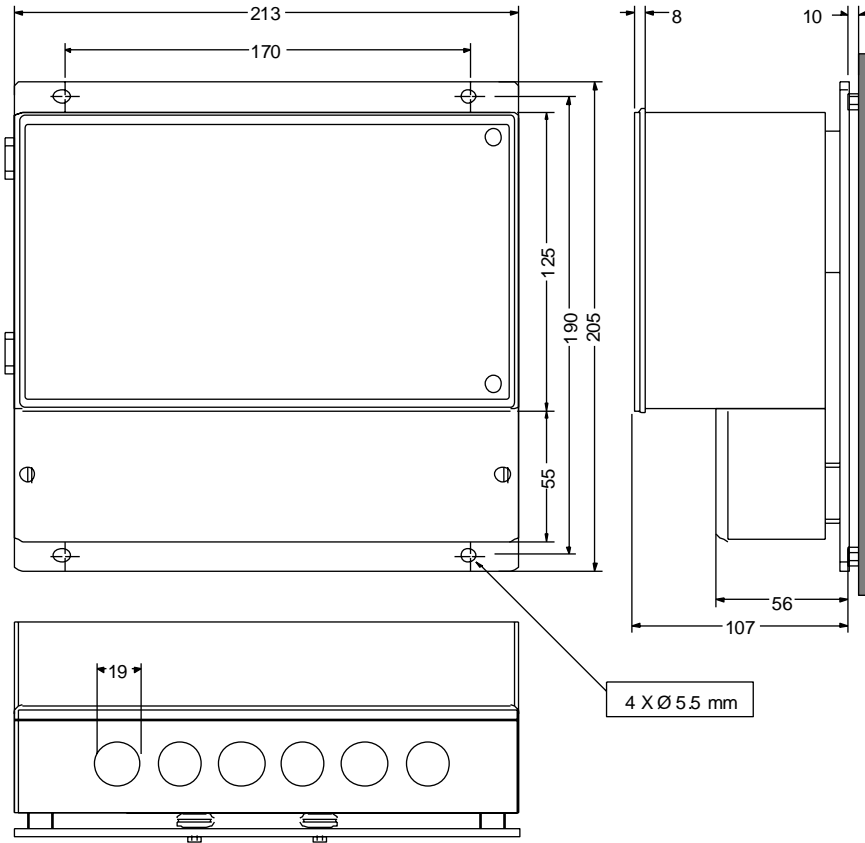

Fig. 12

P35AC

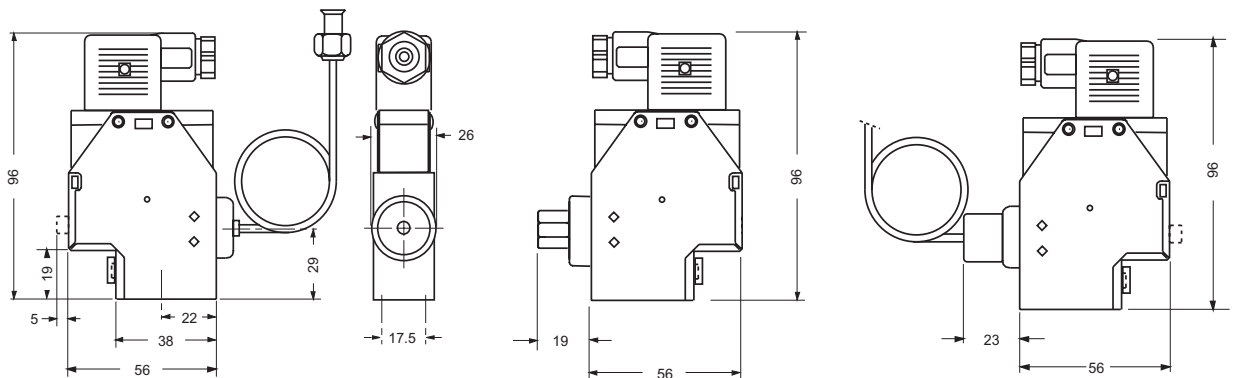

Fig. 13A

Fig. 13B

Fig. 13C

Specifications

Product type	P255MM/ML	
Pressure range	22 to 42 bar 4 to 24 bar 8 to 14 bar	
Maximum overrun pressure	22 to 42 bar = 48 bar 4 to 24 bar = 40 bar 8 to 14 bar = 34 bar	
Pressure connection	style 13, style 45A, style 50 (all with 90 cm of capillary) style 47 (direct mount)	
Control action	direct/reverse	
Maximum output voltage	≥ 96% of supply voltage	
Maximum current	5 A per phase (rms)	
Minimum current	100 mA per phase (rms)	
Power factor (cosφ) motor	≥ 0.6	
Power consumption	nominal 1.5 VA	
Mains supply voltage	P255ML 230 Vac 3 phase +10 % / -15% P255MM400 Vac 3 phase +10 % / -15%	
Mains supply frequency	50/60 Hz	
Operating ambient temp.	-25 to +50 °C	
Operating /storage ambient humidity.	10 to 98 % R.H. (non-condensing)	
Storage ambient Temp.	-40 to 70 °C	
Max. speed adjustment	55 to ≥ 96 % of supply voltage	
Min. speed/ cut-off adjustment	30 to 90 % of supply voltage	
Prop. band range	22 to 42 bar	1 to 8 bar
range	14 to 24 bar	1 to 6 bar
range	8 to 14 bar	0.5 to 4 bar
Hysteresis	5 to 70% of the adjusted prop. band	
Enclosure electronic module	IP54	
pressure transducer	IP20	
Fuses	10 Amp. slow blow glass fuse	
Material: case and cover	Polystyrol	
heatsink	aluminium	
press. connection	90 cm copper capillary with brass flare nut	
Shipping weight	2.3 kg	
Residual current motor	in cut-off mode ≤ 15 mA	
Wiring connections P35AC	screw terminals 1 mm ² up to 1½ mm ²	
P38AD	screw terminals 1 mm ² up to 2½ mm ²	
Dimensions	213 x 205 x 117 (WxHxD)	

The performance specifications are nominal and conform to acceptable industry standards. For applications at conditions beyond these specifications, consult the local Johnson Controls office or representative. Johnson Controls shall not be liable for damages resulting from misapplication or misuse of its products.



Johnson Controls International, Inc.

Headquarters: Milwaukee, WI, USA
 European Headquarters: Westendhof 8, 45143 Essen, Germany
 European Factories: Lomagna (Italy), Leeuwarden (The Netherlands) and Essen (Germany)
 Branch Offices: Principal European Cities.

This document is subject to change

Printed in Europe

Series U215

0-10 Vdc / 4-20 mA Signal Input Fan Speed Controllers for Single Phase Motors (include. built-in RFI suppression filter)

Introduction

These controls can be used to modulate the fan speed in response to the demand of a control system in ventilation applications and VAV systems. A 0-10 Vdc or 4-20 mA signal coming from a (e.g. temperature/ pressure/ humidity/ flow) control loop is used as input while the U215 fan speed controller acts like an actuator.

The controller modulates the speed of single phase permanent split-capacitor or shaded pole motors which do not draw more than 3 A (rms) full load current. The device varies the supply voltage to the motor from 45 % to ≥ 95 % of the supplied voltage using the phase cutting principle.

The motor manufacturer should have approved his product for this speed control principle. It is recommended to confirm with the electric motor manufacturer that the motor can be used with a controller using the phase cutting principle for speed variation. You can also provide a copy of this U215LR product data sheet to the motor manufacturer/supplier for review.



**U215LR 0 - 10 Vdc / 4 - 20 mA
 Signal Input Fan Speed Controller**

Features and Benefits	
<input type="checkbox"/> Built-in suppression filter.	The control meets the electro-magnetic compatibility requirements of the 89/336 EEC directive.
<input type="checkbox"/> Input galvanically separated from high voltage part.	Prevents damage to the control system.
<input type="checkbox"/> Adjustable minimum speed or cut-off selection.	Selection to keep the fan running on (adjusted) minimum rpm or to switch it off.
<input type="checkbox"/> Input selection 0-10 V or 4-20 mA.	Reduces inventory, one model is easier and less costly to stock.
<input type="checkbox"/> Small dimensions.	Easy to fit in small units.
<input type="checkbox"/> DIN rail mounted	Quick to install.

Note

These controls are designed for use only as operating controls. Where an operating control failure would result in personal injury or loss of property it is the responsibility of the installer to add devices or systems that protect against, or warn of, control failure.

! **Caution**

Because the U215LR is a single phase control, it may be used only with single-phase motors approved by the manufacturer for speed control applications.

Installation

The controller consists of a DIN rail mounted electronic module. It can be installed in any convenient location provided that the ambient conditions are suitable for the IP20 enclosure, within the specified limits regarding temperature and humidity and normal pollution situation. More motors can be wired in parallel provided that the total full load current does not exceed 3 Amp (rms).

! **Caution**

To ensure proper operation, the U215LR must be connected to a suitable earth ground.

Wiring (see fig. 1)

To meet the EMC directive shielded cable has to be used for motor wiring. Both sides of the shield have to be connected to earth. To prevent stray current the controller, motor and cable shield connections all have to be connected to one earthing pole. Non-shielded cable may be used if the control and motor are mounted in one frame.

The controller can be used for 4-20 mA as well as for 0-10 V dc input signal.
The current of the 0-10 V dc input signal is max. 2.5mA.

EMC

The controller does have a built-in suppression filter and meets all required EC directives. Please note that when two or more EMC compliant components are built together the total system may not be compliant. To make the total system compliant is the responsibility of the producer.

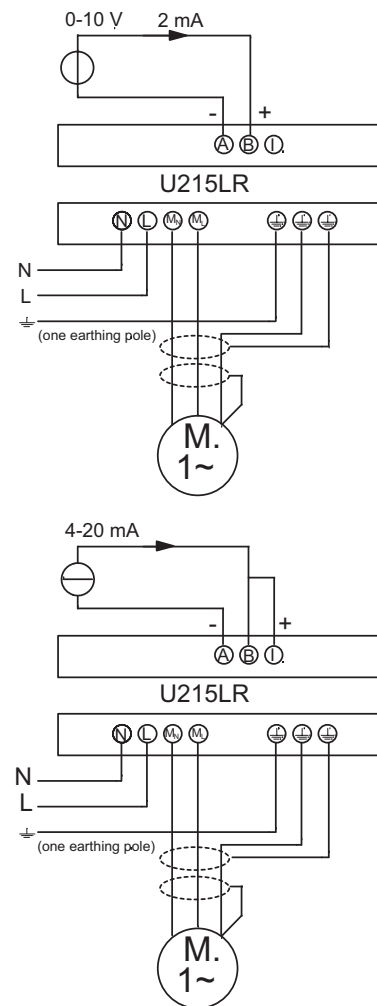
**Fig. 1****Measuring**

For measuring amps or volts values a true rms meter should be used.

! **Caution**

The U215LR is not equipped with a power switch. Therefore an additional switch to isolate the device should be used in the power supply wiring to the U215LR. Also the U215LR should be externally fused against miswiring or short circuits (max. 6 A slow). Use a thermal/current overload relay with a current rating according to the motor.

Adjustments

The controller gives a control characteristic according to fig. 2. The control characteristic can be affected by the load and the supply voltage.

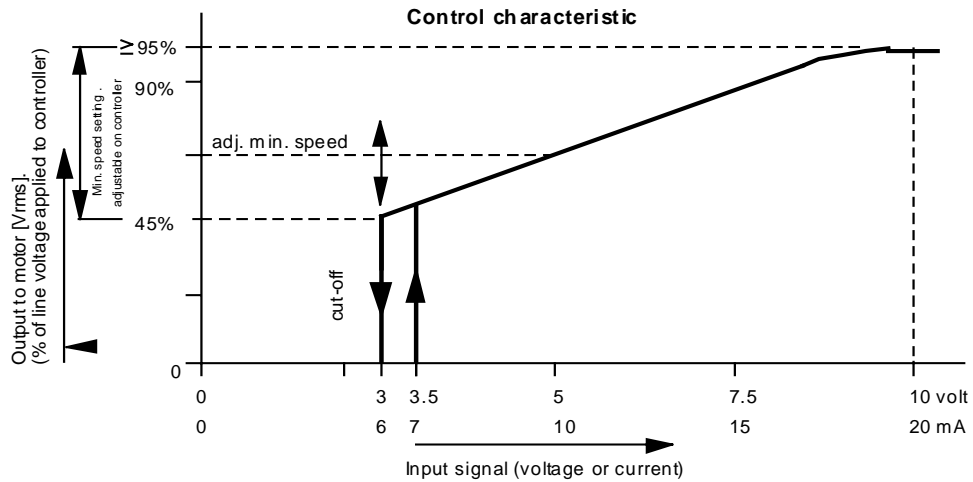

Fig. 2

Minimum speed setting

The minimum speed voltage setting, to prevent fan speed reduction below desirable levels, can be adjusted between 45 % and 90 % of the line voltage by means of the knob on the controller. The minimum speed setting influences the proportional band. A higher setting of the minimum speed results in a smaller proportional band.

Cut-off mode

If minimum speed is not required, turn the knob on the electronic module to the cut-off mode. The output to the motor drops to 0 V when the input signal decreases below 3 V dc or 6 mA (fan stops). There is a built-in fixed hysteresis. The fan starts again as soon as the input signal increases above 3.5 V dc or 7 mA.

Repair and replacement

Repair is not possible. In case of an improperly functioning control, please check with your nearest supplier. When contacting the supplier for a replacement you should state the type-model number of the control. This number can be found on the data plate.

Type number selection

Order number	U215LR - 9110
--------------	---------------

Dimensions

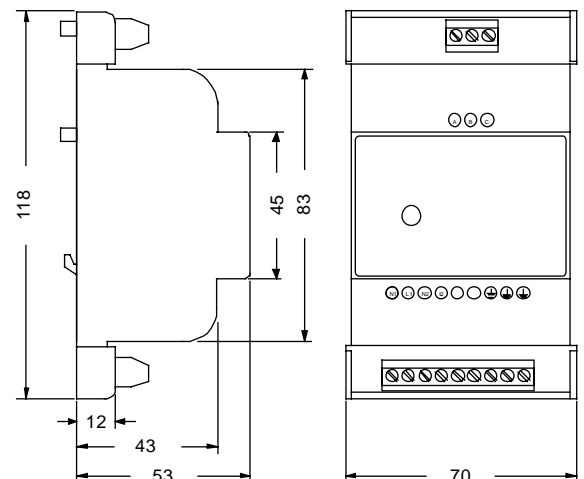

Fig. 3

Specifications

Product type	U215LR
Input signal	4-20 mA 0-10 V dc (The current of the 0-10 V input signal is max. 2.5 mA)
Control action	direct
Maximum output voltage	≥95% of supply voltage
Maximum current	3 A rms (at maximum voltage output)
Minimum current	≥100 mA
Power factor (cosφ) motor	≥0.6
Mains supply voltage	230 V + 10 %/-15 %
Mains supply frequency	50 Hz
Operating ambient temperature	-20 to +55 °C
Operating /storage ambient humidity	10 to 98 % R.H. (non-condensing)
Storage ambient temperature	-40 to +85 °C
Minimum speed	adjustable from 45 to ≥90 % of supply voltage
Cut-off point	45 % of supply voltage
Start voltage	50 % of supply voltage
Enclosure	IP20
Material	enclosure ABS/PC mixture
Shipping weight	individual pack 0.28 kg
Residual current motor	in cut-off mode (at zero input) ≤ 15 mA
Wiring connections	input signal screw terminals 1 mm ² up to 2½ mm ² motor/earth screw terminals 1 mm ² up to 2½ mm ²
Mounting	DIN rail 35 mm.

The performance specifications are nominal and conform to acceptable industry standards. For applications at conditions beyond these specifications, consult the local Johnson Controls office or representative. Johnson Controls shall not be liable for damages resulting from misapplication or misuse of its products.



Johnson Controls International, Inc.

Headquarters: Milwaukee, WI, USA
 European Headquarters: Brussels, Belgium
 European Factories: Lomagna (Italy), Leeuwarden (The Netherlands) and Essen (Germany)
 Branch Offices: Principal European Cities.
 This document is subject to change

www.johnsoncontrols.com
 Printed in Europe

Series U255MM/ML

Voltage Signal Input Fan Speed Controllers

For Three Phase Motors (incl. built-in RFI suppression filter)

Introduction

These controllers are designed for applications where the fan speed must be controlled by a voltage input signal (e.g. 0-10V, 1-5V etc.) from a transmitter or control system.

The signal from one pressure transmitter connected to electronic pressostats, indicators and fan speed control eliminates pressure connections and capillaries through which possible loss of refrigerant is reduced. Head pressure control of a refrigeration system, through speed variation of the fan on an air-cooled condenser, results in optimum performance throughout the year.

The controller varies the supply voltage to the motor from 30% to at least 96% over the proportional band using the phase cutting principle. Motors that will be controlled by the U255 should not draw more than 5 A per phase.



**U255MM/ML
Fan Speed Controller**

Feature and Benefits

<input type="checkbox"/> Adjustable voltage input.	Can be used for a wide range of voltage input signals.
<input type="checkbox"/> Allows connection in both "Star" and "Delta" configurations.	3 wire motor connection for both "Star" and "Delta" connection.
<input type="checkbox"/> Built-in suppression filter.	The control meets the electro magnetic compatibility requirements of the 89/336/EEC directive.
<input type="checkbox"/> Contact input to force output to max. or off.	Control interrupt possibility.
<input type="checkbox"/> Built-in power supply.	15 V dc power supply for sensor.
<input type="checkbox"/> Built-in direct/reverse action selector switch.	Easy change over from direct to reverse control action
<input type="checkbox"/> IP54 enclosure.	Can be mounted outdoor.
<input type="checkbox"/> Built-in set point adjustment.	Easy set point adjustment on application.
<input type="checkbox"/> Minimum speed or cut-off selection.	Selection to keep the fan running on minimum speed or to switch it off.
<input type="checkbox"/> Adjustable minimum speed or cut-off Adjustable maximum speed limit. Proportional band adjustment.	Maximum flexibility to adjust cooling capacity and/or to get the best motor performance.
<input type="checkbox"/> Adjustable hysteresis in cut-off mode.	Easy motor start by adjustable start voltage.
<input type="checkbox"/> Cosφ motor adjustment.	Optimum control and motor performance.

Electric motor selection

Care must be taken when selecting an electric motor as the controller uses the phase cutting principle for variation of motor speed. This will cause additional heat generation in the stator (motor winding) and the rotor of the motor, especially at medium speed.

At medium speed the current to the motor will be at its highest level whereas the cooling of the motor has already substantially decreased. Motors that are designed to handle this extra heat generation are preferred. The use of thermal motor winding protection switches is advised. Often (depending on the total application conditions) a class F motor should be used to handle the temperature increase. Motors with lower temperature classification might be interrupted by the temperature protection switches, which are embedded in the motor windings. Finally, the motor should have bearings that provide sufficient lubrication at lower RPM and possibly increased shaft temperatures.

It is recommended to confirm with the electric motor manufacturer, that the motor can be used with a controller, using the phase cutting principle for speed variation. You can also provide a copy of this U255 product data sheet to the motor manufacturer/supplier for review.

Note

At lower speeds (between 50% and 75% of rpm mentioned on the motor data plate), depending on motortype and load, the max. current can become higher than I nominal of the motor. In case the max. current increases above 5 Amp. the max. allowed ambient temperature will become lower as indicated in the diagram (see fig. 1).

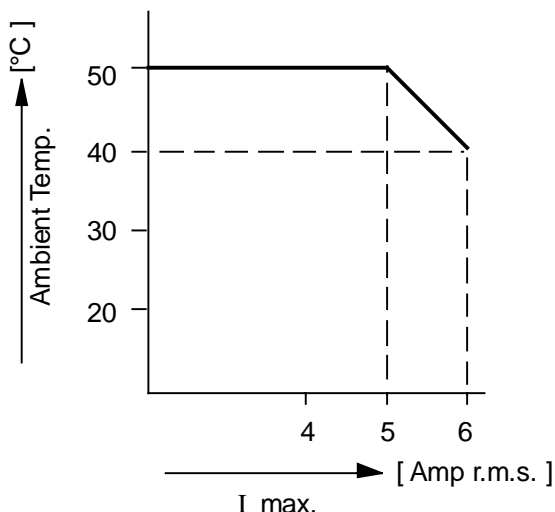

Fig. 1

Note

The U255MM/ML is intended to control equipment under normal operating conditions. Where failure or malfunction of the P255MM/ML could lead to an abnormal operating condition that could cause personal injury or damage to the equipment or other property, other devices (limit or safety controls) or systems (alarm or supervisory systems) intended to warn of or protect against failure or malfunction of the P255MM/ML must be incorporated into and maintained as part of the control system.

Installation

Mount the controller in a vertical position. The controller is provided with spacers to create at least 10 mm distance between the mounting surface and the heatsink. For proper air-circulation there should be a clearance around the controller of at least 50 mm. When mounted inside a cabinet, holes for air-circulation should be provided. If the U255 cannot be mounted vertically, additional limitations apply. The maximum allowable current will be 3.5 A instead of 5 A or the maximum allowable ambient temperature is reduced to 35 °C instead of 50 °C.

Wiring motor

The motor can be wired in Star or Delta. To meet the EMC directive shielded cable has to be used for motor wiring in case the distance between controller and motor is more than 2 meters. If the distance is less than 2 meters it is allowed to use non-shielded cable. (see fig. 2).

Non shielded cable may be used if the control and motor are mounted in one frame.

Both sides of the shield have to be connected. To prevent stray current, the two earth connections of the controller, the motor earth connection as well as the cable shield, all have to be connected to one earthing pole (see fig. 2).

More motors can be wired in parallel, provided that the total current will not exceed 5 A rms.

EMC

The controller does have a built-in suppression filter and meets all required EC directives. Please note that when two or more EMC compliant components are built together the total system may not be compliant. To make the total system compliant is the responsibility of the producer.

Wiring input signal

The voltage input signal must be wired according to fig.2. (terminal A is zero, B0 is 0-10V signal). A 15 Vdc power supply for a transmitter (5 mA max.) is available on terminal C.



Warning

The input signal to the control may not become lower than 0 V.

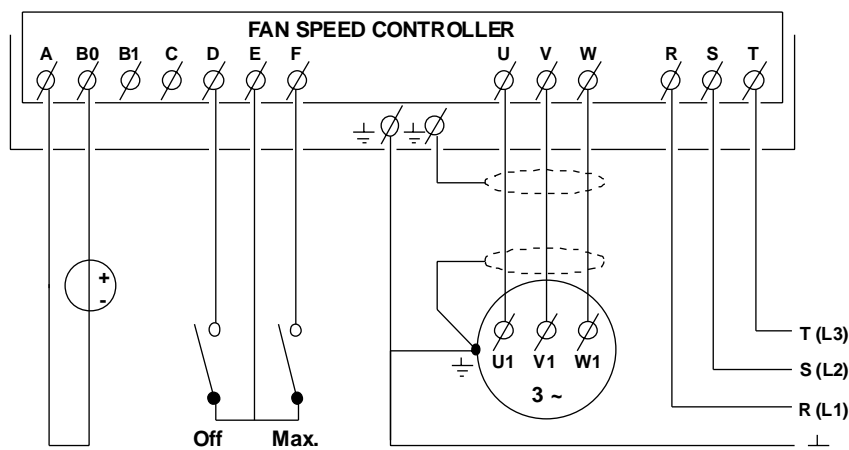

Fig. 2

Control action (direct/reverse)

The controller will be delivered for direct action (out-put voltage increases at increasing input signal voltage). If reverse action is desired this can be obtained by changing the direct/reverse switch to position "Reverse" (see fig. 4).

Max. speed / fan off

A potential free contact can be connected to the U255 to force the output to maximum (output $\geq 96\%$ of supply voltage) or to switch the fan off (see fig. 2).

Terminal E is the common. If E is connected to F the fan goes to max. speed. If E is connected to D the fan is switched off.

Measuring

For measuring amps or volts values a true rms meter should be used.

Caution

The U255 is not equipped with a power switch. Therefore an additional switch to isolate the device should be used in the power supply wiring to the U255.

For motor protection the use of thermal motor winding protection switches is preferred. If a thermal/current overload relay is used the max. current (between 50% and 75% of the speed) should be measured to set the overload relay. A larger difference between I_{nom} and I_{max} results in an insufficient motor protection.

Fuses

Controller damage, caused by too high load, will be prevented /limited by the built-in 10A glass fuses. In case of malfunctioning of the controller these fuses should be checked first.

For protection of the main power wiring external 400V NEOZED or 500V DIAZET fuses can be used. The required fuse amperage depends on the used wiring. See below table.

1 mm ²	6 Amp
1.5 mm ²	10 Amp
2.5 mm ²	16 Amp

Selection 50/60 Hz (see fig.4)

The control will be delivered for use on 50 Hz supply frequency. For 60 Hz selection the selector switch position must be changed to 60 Hz

Adjustments

The U255 gives a control characteristic according to fig. 3

The control characteristic is affected by the load and the supply voltage.

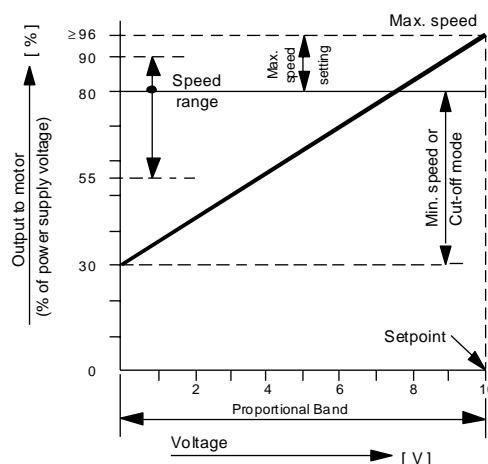

Fig. 3 Factory adjusted characteristic

Adjustable settings: (see Fig. 4 and 5)

Setpoint	0.5 to 10 V
Speed range	55 to 90% of supply voltage
Max. speed	55 to $\geq 96\%$ of supply voltage
Min. speed	30 to 90% of supply voltage
Cut-off	30 to 90% of supply voltage
Prop. band	0.7 to 10 V
Hysteresis	5 to 70% of adj. prop. band
Cos ϕ	0.6 to 1

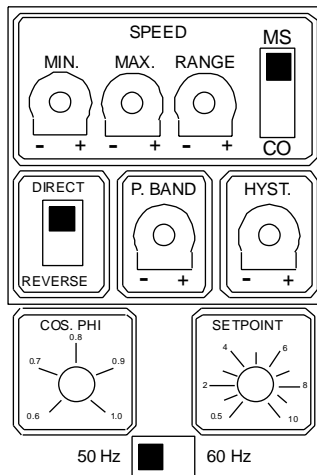

Fig. 4

Factory settings

Setpoint	10 V
Speed range	80%
Max. speed	$\geq 96\%$
Min. speed	30%
Prop. band	10 V
Hysteresis	5%
Cos ϕ	0.8
MS/CO switch position	MS
50/60 Hz switch position	50 Hz
Direct/reverse switch position	Direct

The controller will be delivered with these settings.

Setpoint

The setpoint (point A) at which the control delivers maximum output can be adjusted by the "SET POINT" potentiometer (see fig. 4) inside the controller between 0.5 to 10 Volt

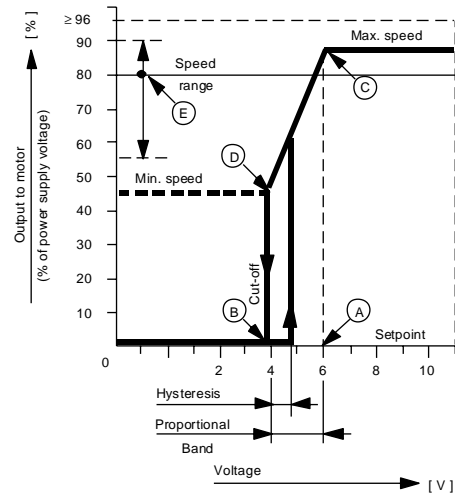

Fig. 5

Maximum speed limit

It is possible to adjust a maximum speed limit (point C). This means that the output to the motor will not increase above the adjusted setting. The maximum speed limit can be adjusted with potentiometer "MAX." inside the controller (see fig. 4). The maximum output voltage to the motor is adjustable from the adjusted speed range line up to $\geq 96\%$ of the power supply voltage.

Minimum speed

The minimum speed voltage setting (point D), to prevent fan speed reduction below desirable levels, can be adjusted from 30% of the power supply voltage up to the adjusted speed range line by means of potentiometer "MIN." inside the controller and selector switch MS/CO set to minimum speed mode MS (see fig. 4).

Speed range line

The max. speed adjustment is independent from the min. speed adjustment. To prevent that the min. speed is set to a higher value than max. speed (no output any more) the "speed range line" is introduced. This (imaginary) line divides the output characteristic into an upper part and lower part.

The maximum speed can be adjusted in the upper part (from $\geq 96\%$ down to the adjusted speed range value). The minimum speed/cut-off can be adjusted in the lower part (from 30% up to the adjusted speed range value). The speed range line (point E) can be adjusted with the speed "RANGE" potentiometer (see fig. 4) from 55% to 90% of the power supply voltage.

Cut-off mode

In the cut-off mode the output to the motor will drop to zero if the input signal decreases below point B. The fan stops.

The cut-off can be adjusted from 30% of the power supply voltage up to the adjusted speed range line by means of potentiometer "MIN." inside the controller and the selector switch MS/CO set to cut-off mode CO (see fig. 4).

Proportional band

The proportional band is the difference between the signal input voltage at which the output to the motor is 0 V (point B) or the minimum speed voltage (point D) and the signal input voltage value at setpoint (point A). The proportional band is adjustable with potentiometer "P-BAND" inside the controller (see fig. 4) from 0.7 V up to 10 V.

Hysteresis

A running fan can be controlled to a low speed. Sometimes it gives trouble starting at this low speed. Therefore it is possible to adjust the hysteresis which means the motor starts at a higher voltage. The hysteresis can be adjusted by potentiometer "HYST." between 5% and 70% of the adjusted proportional band (see fig. 4).

Cosφ

On the motor data plate the $\cos\phi$ of the motor is indicated. To get the most optimal control the "COSPHI" potmeter (see fig. 4) must be set to this value. If $\cos\phi$ is not known the potmeter can be set to 0.8

Repair and replacement

Repair is not possible. In case of an improperly functioning control, please check with your nearest supplier. When contacting the supplier for a replacement you should state the type-model number of the control. This number can be found on the data plate.

Type number selection

Order nr.	Supply voltage
U255ML-9100	230 V - 3 phase
U255MM-9100	400 V - 3 phase

Dimensions (mm)

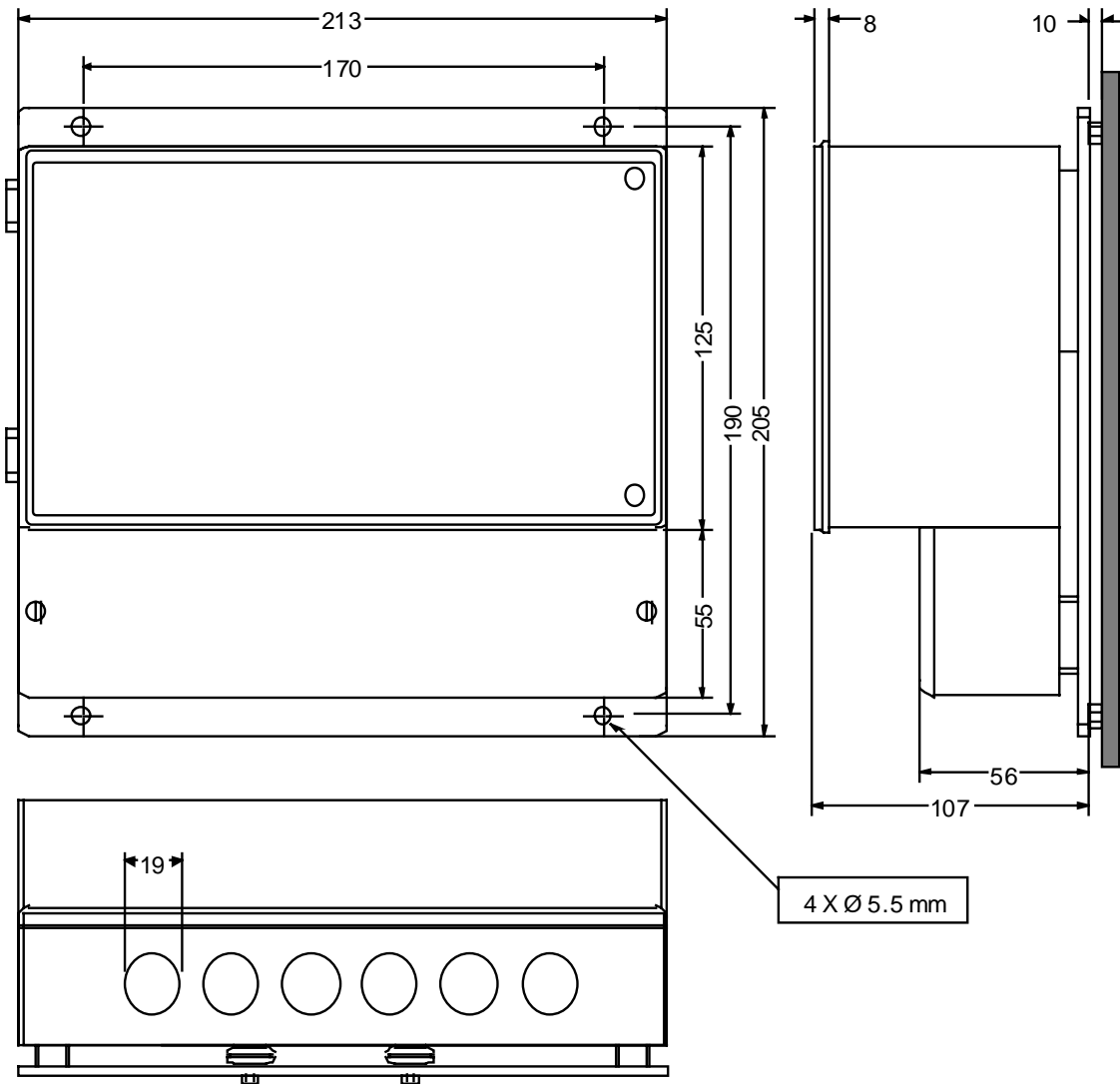

Fig. 6

Note

Specifications

Product type	U255MM/ML
Power supply for transmitter	15 V dc max. 5mA.
Input	Voltage input 0 to 10 V or within range 0 to 10 V. Input impedance 1 M Ohm
Control action	direct/reverse
Maximum output voltage	≥ 96% of supply voltage
Maximum current	5 A per phase (rms)
Minimum current	0.1 A per phase (rms)
Power factor (cosφ) motor	≥ 0.6
Power consumption	nominal 1.5 VA
Mains supply voltage	U255ML 230V 3 phase +10%/-15% U255MM 400V 3 phase +10%/-15%
Mains supply frequency	50/60 Hz
Operating ambient temp.	-25 to +50 °C
Operating /storage ambient humidity.	10 to 98 % R.H. (non-condensing)
Storage ambient Temp.	-40 to 70 °C
Max. speed adjustment	55 to ≥ 96 % of supply voltage
Min. speed/ cut-off adjustment	30 to 90 % of supply voltage
Prop. band	0.7 to 10 V
Hysteresis	5 to 70% of the adjusted prop. band
Enclosure	IP54
Fuses	10 Amp. slow blow glass fuse
Material: case and cover	Polystyrol
 heatsink	aluminium
Shipping weight	2.0 kg
Residual current motor	in cut-off mode ≤ 15 mA
Wiring connections	screw terminals 1 mm ² up to 2½ mm ²
Dimensions	213 x 205 x 117 (WxHxD)

The performance specifications are nominal and conform to acceptable industry standards. For applications at conditions beyond these specifications, consult the local Johnson Controls office or representative. Johnson Controls shall not be liable for damages resulting from misapplication or misuse of its products.



Johnson Controls International, Inc.

Headquarters: Milwaukee, WI, USA
 European Headquarters: Westendhof 8, 45143 Essen, Germany
 European Factories: Lomagna (Italy), Leeuwarden (The Netherlands) and Essen (Germany)
 Branch Offices: Principal European Cities.

This document is subject to change

Printed in Europe

Series A255MM/ML

Temperature Sensor Input Fan Speed Controllers For Three Phase Motors (incl. built-in RFI suppression filter)

Introduction

These controllers are designed for applications where the fan speed must be controlled by a temperature sensor input signal .

The controller varies the supply voltage to the motor from 30 % to at least 96 % over the proportional band using the phase cutting principle. Motors that will be controlled by the A255 should not draw more than 5 A per phase.



A255MM/ML
Fan Speed Controller

Feature and Benefits

<input type="checkbox"/> Various temperature sensor enclosures to match many applications.	Can be used with a wide range of Johnson Controls temperature sensors.
<input type="checkbox"/> Allows connection in both "Star" and "Delta" configurations.	3 wire motor connection for both "Star" and "Delta" connection.
<input type="checkbox"/> Built-in suppression filter.	The control meets the electro magnetic compatibility requirements of the 89/336/EEC directive.
<input type="checkbox"/> Contact input to force output to max. or off.	Control interrupt possibility.
<input type="checkbox"/> Built-in direct/reverse action selector switch.	Easy change over from direct to reverse control action
<input type="checkbox"/> IP54 enclosure.	Can be mounted outdoor.
<input type="checkbox"/> Built-in set point adjustment.	Easy set point adjustment on application.
<input type="checkbox"/> Minimum speed or cut-off selection.	Selection to keep the fan running on minimum speed or to switch it off.
<input type="checkbox"/> Adjustable minimum speed or cut-off.	Maximum flexibility to adjust cooling capacity and/or to get the best motor performance.
<input type="checkbox"/> Adjustable maximum speed limit.	
<input type="checkbox"/> Proportional band adjustment.	
<input type="checkbox"/> Adjustable hysteresis in cut-off mode.	Easy motor start by adjustable start voltage.
<input type="checkbox"/> Cosφ motor adjustment.	Optimum control and motor performance.

Electric motor selection

Care must be taken when selecting an electric motor as the controller uses the phase cutting principle for variation of motor speed. This will cause additional heat generation in the stator (motor winding) and the rotor of the motor, especially at medium speed.

At medium speed the current to the motor will be at its highest level whereas the cooling of the motor has already substantially decreased. Motors that are designed to handle this extra heat generation are preferred. The use of thermal motor winding protection switches is advised. Often (depending on the total application conditions) a class F motor should be used to handle the temperature increase. Motors with lower temperature classification might be interrupted by the temperature protection switches, which are embedded in the motor windings. Finally, the motor should have bearings that provide sufficient lubrication at lower RPM and possibly increased shaft temperatures.

It is recommended to confirm with the electric motor manufacturer, that the motor can be used with a controller, using the phase cutting principle for speed variation. You can also provide a copy of this A255 product data sheet to the motor manufacturer/supplier for review.

Note

At lower speeds (between 50% and 75% of rpm mentioned on the motor data plate), depending on motortype and load, the max. current can become higher than 1 nominal of the motor. In case the max. current increases above 5 Amp. the max. allowed ambient temperature will become lower as indicated in the diagram (see fig. 1).

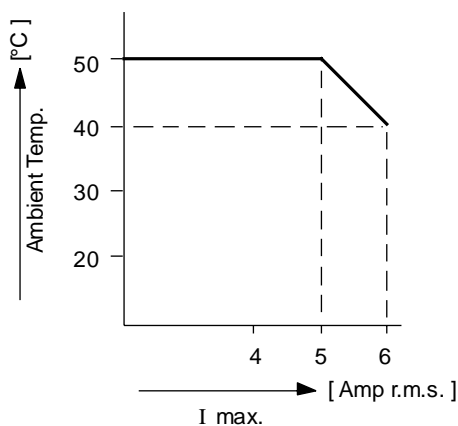

Fig. 1

Note

The A255MM/ML is intended to control equipment under normal operating conditions. Where failure or malfunction of the P255MM/ML could lead to an abnormal operating condition that could cause personal injury or damage to the equipment or other property, other devices (limit or safety controls) or systems (alarm or supervisory systems) intended to warn or protect against failure or malfunction of the P255MM/ML must be incorporated into and maintained as part of the control system.

Installation

Mount the controller in a vertical position. The controller is provided with spacers to create at least 10 mm distance between the mounting surface and the heatsink. For proper air-circulation there should be a clearance around the controller of at least 50 mm. When mounted inside a cabinet, holes for air-circulation should be provided. If the A255 cannot be mounted vertically, additional limitations apply. The maximum allowable current will be 3.5 A instead of 5 A or the maximum allowable ambient temperature is reduced to 35 °C instead of 50 °C

Wiring motor

The motor can be wired in Star or Delta. To meet the EMC directive shielded cable has to be used for motor wiring in case the distance between controller and motor is more than 2 meters. If the distance is less than 2 meters it is allowed to use non-shielded cable. (see fig. 2).

Non shielded cable may be used if the control and motor are mounted in one frame.

Both sides of the shield have to be connected. To prevent stray current, the two earth connections of the controller, the motor earth connection as well as the cable shield, all have to be connected to one earthing pole (see fig. 2).

More motors can be wired in parallel, provided that the total current will not exceed 5 A rms.

EMC

The controller does have a built-in suppression filter and meets all required EC directives. Please note that when two or more EMC compliant components are built together the total system may not be compliant. To make the total system compliant is the responsibility of the producer.

Wiring temperature sensor

All Johnson Controls A99X-91XX sensors, mentioned in A99 bulletin PD-A99, can be connected to the A255 (sensor has to be ordered separately). Sensor wires have to be connected to terminals A and B0. Sensor is not polarity sensitive (see fig. 2).

Sensor wiring should be separated from high voltage or wiring that supplies inductive loads (contactors, coils, motors, relays etc.). If not possible shielded cable must be used. Connect one side of the shield to earth (ground). Do not use sensor wire length above 200 m. When the sensor wiring is completely remote from high voltage or inductive wiring, unshielded cable can (may) be used. In those cases the wiring length must be limited to 50m

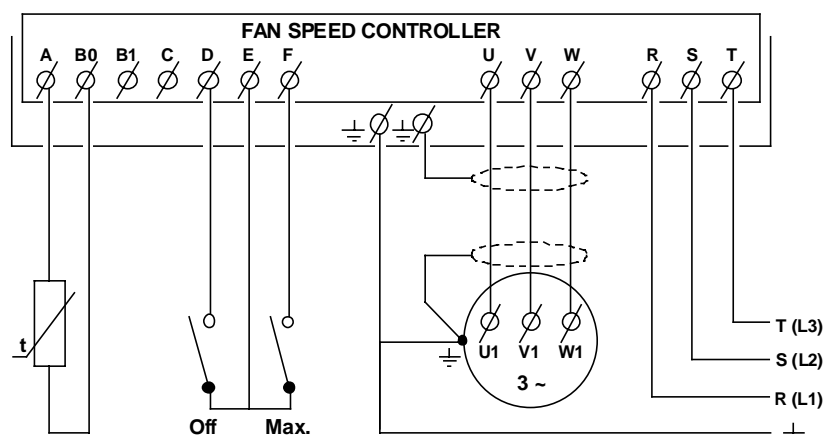

Fig. 2

Control action (direct/reverse)

The controller will be delivered for direct action (output voltage increases at increasing temperature). If reverse action is desired this can be obtained by changing the direct/reverse switch to position "Reverse" (see fig. 4).

Max. speed / fan off

A potential free contact can be connected to the A255 to force the output to maximum (output $\geq 96\%$ of supply voltage) or to switch the fan off (see fig. 2).

Terminal E is the common. If E is connected to F the fan goes to max. speed. If E is connected to D the fan is switched off.

Measuring

For measuring amps or volts values a true rms meter should be used.

Caution

The A255 is not equipped with a power switch. Therefore an additional switch to isolate the device should be used in the power supply wiring to the A255.

For motor protection the use of thermal motor winding protection switches is preferred. If a thermal/ current overload relay is used the max. current (between 50% and 75% of the speed) should be measured to set the overload relay. A larger difference between $I_{nom.}$ and $I_{max.}$ results in an insufficient motor protection.

Fuses

Controller damage, caused by too high load, will be prevented /limited by the built-in 10A glass fuses. In case of malfunctioning of the controller these fuses should be checked first.

For protection of the main power wiring external 400V NEOZED or 500V DIAZET fuses can be used. The required fuse amperage depends on the used wiring. See below table.

1 mm ²	6 Amp
1.5 mm ²	10 Amp
2.5 mm ²	16 Amp

Selection 50/60 Hz (see fig.4)

The control will be delivered for use on 50 Hz supply frequency. For 60 Hz selection the selector switch position must be changed to 60 Hz.

Adjustments

The A255 gives a control characteristic according to fig. 3

The control characteristic is affected by the load and the supply voltage.

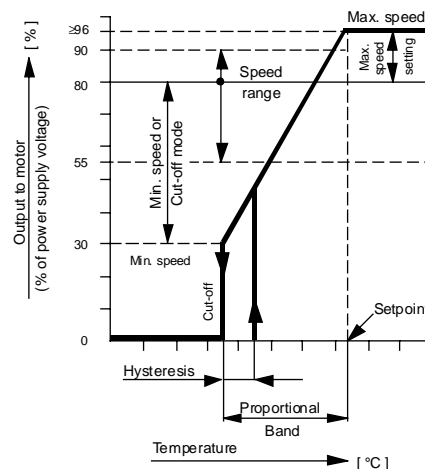

Fig. 3
Factory adjusted characteristic

Adjustable settings: (See Fig. 4 and 5)

Setpoint	0 to 65 °C
Speed range	55 to 90% of supply voltage
Max. speed	55 to $\geq 96\%$ of supply voltage
Min. speed	30 to 90% of supply voltage
Cut-off	30 to 90% of supply voltage
Prop. band	1 to 10 K
Hysteresis	5 to 70% of adj. prop. band
Cos ϕ	0.6 to 1

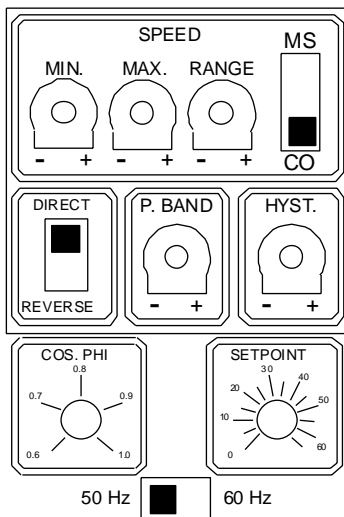

Fig.4

Factory settings

Setpoint	45 °C
Speed range	80%
Max. speed	$\geq 96\%$
Cut off	30%
Prop. band	10 K
Hysteresis	5%
Cos ϕ	0.8
MS/CO switch position	CO
50/60 Hz switch position	50 Hz
Direct/reverse switch position	Direct

The controller will be delivered with these settings.

Setpoint

The setpoint (point A) at which the control delivers maximum output can be adjusted by the "SET POINT" potentiometer (see fig. 4) inside the controller between 0 to 65 °C.

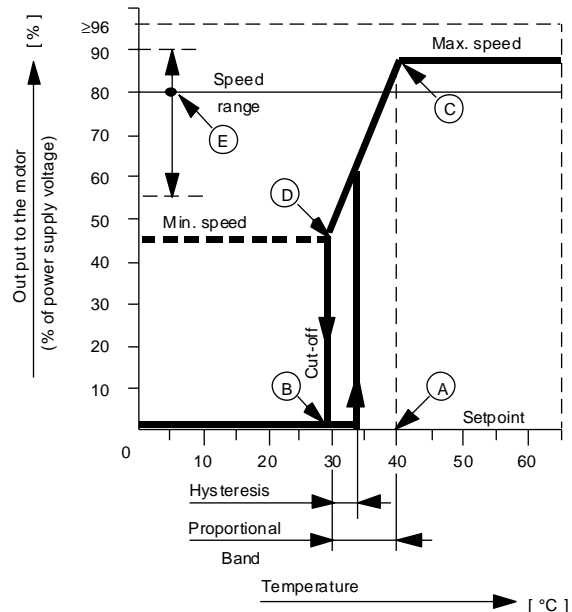

Fig. 5

Maximum speed limit

It is possible to adjust a maximum speed limit (point C). This means that the output to the motor will not increase above the adjusted setting. The maximum speed limit can be adjusted with potentiometer "MAX." inside the controller (see fig. 4). The maximum output voltage to the motor is adjustable from the adjusted speed range line up to $\geq 96\%$ of the power supply voltage.

Minimum speed

The minimum speed voltage setting (point D), to prevent fan speed reduction below desirable levels, can be adjusted from 30% of the power supply voltage up to the adjusted speed range line by means of potentiometer "MIN." inside the controller and selector switch MS/CO set to minimum speed mode MS (see fig. 4).

Speed range line

The max. speed adjustment is independent from the min. speed adjustment. To prevent that the min. speed is set to a higher value than max. speed (no output any more) the "speed range line" is introduced. This (imaginary) line divides the output characteristic into an upper part and lower part.

The maximum speed can be adjusted in the upper part (from $\geq 96\%$ down to the adjusted speed range value). The minimum speed/cut-off can be adjusted in the lower part (from 30% up to the adjusted speed range value). The speed range line (point E) can be adjusted with the speed "RANGE" potentiometer (see fig. 4) from 55% to 90% of the power supply voltage.

Cut-off mode

In the cut-off mode the output to the motor will drop to zero if the temperature decreases below point B. The fan stops.

The cut-off can be adjusted from 30% of the power supply voltage up to the adjusted speed range line by means of potentiometer "MIN." inside the controller and the selector switch MS/CO set to cut-off mode CO (see fig. 4).

Proportional band

The proportional band is the difference between the temperature at which the output to the motor is 0 V (point B) or the minimum speed voltage (point D) and the temperature at setpoint (point A).

The proportional band is adjustable with potentiometer "P-BAND" inside the controller (see fig. 4) from 1 up to 10 K.

Hysteresis

A running fan can be controlled to a low speed. Sometimes it gives trouble starting at this low speed. Therefore it is possible to adjust the hysteresis which means the motor starts at a higher voltage. The hysteresis can be adjusted by potentiometer "HYST." between 5% and 70% of the adjusted proportional band (see fig. 4).

Cosφ

On the motor data plate the $\cos\phi$ of the motor is indicated. To get the most optimal control the "COSPHI" potmeter (see fig. 4) must be set to this value. If $\cos\phi$ is not known the potmeter can be set to 0.8

Repair and replacement

Repair is not possible. In case of an improperly functioning control, please check with your nearest supplier. When contacting the supplier for a replacement you should state the type-model number of the control. This number can be found on the data plate.

Type number selection

Order nr.	Supply voltage
A255ML-9100	230 V - 3 phase
A255MM-9100	400 V - 3 phase

Dimensions (mm)

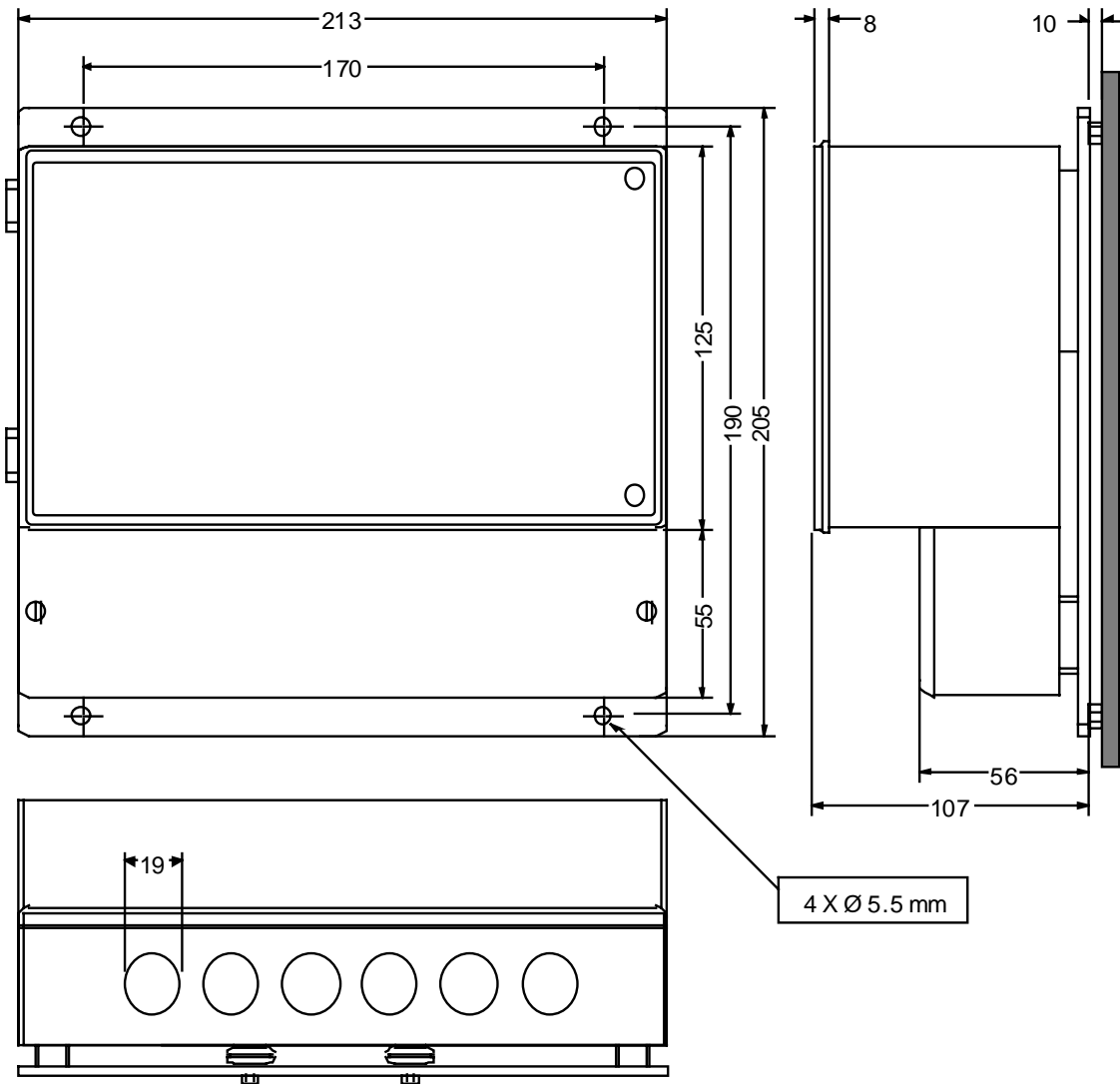

Fig. 6

Note

Specifications

Product type	A255MM/ML
Setpoint range	0 to 65 °C
Input	A99X-91XX sensors according to bulletin PD-A99
Control action	direct/reverse
Maximum output voltage	≥ 96% of supply voltage
Maximum current	5 A per phase (rms)
Minimum current	0.1 A per phase (rms)
Power factor (cosφ) motor	≥ 0.6
Power consumption	nominal 1.5 VA
Mains supply voltage	A255ML 230V 3 phase +10%/-15% A255MM 400V 3 phase +10%/-15%
Mains supply frequency	50/60 Hz
Operating ambient temp.	-25 to +50 °C
Operating /storage ambient humidity.	10 to 98 % R.H. (non-condensing)
Storage ambient Temp.	-40 to 70 °C
Max. speed adjustment	55 to ≥ 96 % of supply voltage
Min. speed/ cut-off adjustment	30 to 90 % of supply voltage
Prop. band	1 to 10 K
Hysteresis	5 to 70% of the adjusted prop. band
Enclosure	IP54
Fuses	10 Amp. slow blow glass fuse
Material: case and cover	Polystyrol
 heatsink	aluminium
Shipping weight	2.0 kg
Residual current motor	in cut-off mode ≤ 15 mA
Wiring connections	screw terminals 1 mm ² up to 2½ mm ²
Dimensions	213 x 205 x 117 (WxHxD)

The performance specifications are nominal and conform to acceptable industry standards. For applications at conditions beyond these specifications, consult the local Johnson Controls office or representative. Johnson Controls shall not be liable for damages resulting from misapplication or misuse of its products.



Johnson Controls International, Inc.

Headquarters: Milwaukee, WI, USA
 European Headquarters: Westendhof 8, 45143 Essen, Germany
 European Factories: Lomagna (Italy), Leeuwarden (The Netherlands) and Essen (Germany)
 Branch Offices: Principal European Cities.

This document is subject to change

Printed in Europe

Series V46

Pressure Actuated Modulating Valves

Introduction

These pressure actuated modulating valves control the quantity of water to a condenser by directly sensing pressure changes in a refrigerant circuit. The valves can be used in non-corrosive refrigerant systems. Ammonia power elements and valves designed for salt-water applications are available. The valves have a quick opening characteristic and open on pressure increase (direct acting). Reverse acting (close on pressure increase) is possible.



Series V46
Pressure Actuated Water Regulating Valve

Feature and Benefits	
<input type="checkbox"/> Pressure balanced valve design	Setpoint is independent from water inlet pressure
<input type="checkbox"/> High refrigerant pressure resistant bellows	Refrigeration pressure may increase up to 28 bar without bellow damage
<input type="checkbox"/> Pressure actuated	Direct and fast response to pressure variations
<input type="checkbox"/> 3/8, 1/2, 3/4" are angled body type valves with high Kv value	Small dimensions with high flow capacity
<input type="checkbox"/> 3/8" up to 2" pressure valves "all range" types	Reduces stock. One valve for all non-corrosive refrigerants
<input type="checkbox"/> Quick opening valve characteristics	Fast response to pressure increase
<input type="checkbox"/> No close fitting or sliding parts in water passages	No hysteresis increase or stuck valve caused by contamination
<input type="checkbox"/> Easy to disassemble. All parts can be replaced	Valve can easily be repaired "in line". Valve piece parts are available "world-wide"
<input type="checkbox"/> Special bronze bodies and monel parts	Used for sea water applications
<input type="checkbox"/> Power elements with stainless steel bellows available	For use on ammonia filled equipment
<input type="checkbox"/> Wide range of pressure connection styles	Possibility to meet the legislation in your country
<input type="checkbox"/> Nickel plated seats available for 3/8, 1/2, and 3/4" valves	High resistant against erosion/ corrosion and cavitation
<input type="checkbox"/> Direct/reverse action	Control action can be (factory) changed

Note

All series V46 water regulating valves are designed for use only as operating devices. Where system closure, improper flow or loss of pressure due to valve failure can result in personal injury and/or loss of property, a separate pressure relief or safety shut off valve, as applicable, must be added by the user.

Description

A pressure-balanced design employing rubber sealing diaphragms correctly proportioned to the valve port area, balances valve against both gradual and sudden water pressure changes, and seals water away from range spring, guides and sliding parts so these are not submerged in water where they would be subject to sedimentation and corrosion. Only five metal parts, made of corrosion resistant material, come in contact with the water. These are the valve disc holder, the disc stud, the valve seat, the valve stem, and the body.

Adjustments

The pressure at which the valve starts to open (= opening point) can be adjusted by the adjusting screw located at the top of the range spring housing. Valves may be adjusted with standard service valve wrenches or screwdrivers. (Valves are not factory set at a certain value.)

Manual flushing

Valves may be manually flushed by lifting the lower spring guide with screwdrivers at two sides of the pressure plate to open valve. This does not affect valve adjustment.

Valve size selection

The valve size is determined by three data:

- The required maximum flow (quantity of liquid = Q) that must pass the valve (in m³/h).
- The maximum allowed pressure drop (= ΔP) across the valve (in bar).
- The head pressure rise (= HPR) which is the difference between the pressure where the valve starts to open and the condenser operating pressure.

Note

At a certain pressure the valve starts to open. If the pressure decreases, the valve will close again at a $\approx 0,5$ bar lower pressure than the pressure where the valve starts to open.

Note

If the compressor operates in a high ambient temperature, the refrigerant pressure may at times remain high enough to cause the valve to partly open when the compressor is idle. In such conditions the valve opening point should be raised just enough to cause the valve to close during compressor standby periods. Take this into account when the head pressure rise (HPR) is calculated.

The valve size can be selected by the use of:

- the diagram (see page 3 and 4).
- K_V factors and calculation formulae (see page 3). This can only be used when the allowed head pressure rise is 3 bar or higher. At lower head pressure rises the diagram has to be used.

Valve size selection by the use of the diagram page 4

Q: The quantity of water (m³/h) is indicated on the left side of the upper diagram (= scale A).

P: The curves for the pressure drop across the valve are indicated in the lower diagram (0,1 up to 4 bar, see scale C).

HPR: The head pressure rise above the valve opening point is indicated at the left side of the lower diagram (max. 4 bar, see scale B).

Note

There are two vertical head pressure rise scales. The left side for range 5/18 bar valves and the right side for high ranges 5/23 and 10/23 bar valves.

Valve size: The valve size can be read from the right side of the upper diagram.

Valve size selection example:

$$\begin{aligned} Q &= 6,5 \text{ m}^3/\text{h} \\ \text{HPR} &= 2,7 \text{ bar} \\ \Delta P &= 0,5 \text{ bar} \end{aligned}$$

- Draw a horizontal line through the 6,5 m³/h point of scale A (see A).
- Draw a horizontal line through the 2,7 bar of scale B (see B). The intersection of this horizontal line with the delta P curve of 0,5 bar is used to draw a vertical line from this intersection point up to the horizontal line in scale A (see C).
- The intersection point of this vertical line with the horizontal line in scale A indicates the valve size. If the point falls on a size curve, this is the valve size needed. If it is between two sizes always take the largest valve size. In this example it is between size 1¹/₄" and 1¹/₂".
The selected valve is 1¹/₂".

Of course the same diagram can be used to read the pressure drop across a valve or to find the maximum capacity of a valve.

E.g. Pressure drop.

Q needed is 6 m³/h.
HPR is 2,5 bar.
The valve size available is 3/4".
What will be the pressure drop?

Solution:

- Draw a horizontal line through 6 m³/h (scale A) and determine the intersection of this line with the 3/4" valve curve.
 - Draw a vertical line from this intersection point to the 2,5 bar HPR line.
 - The found part is between the 2 and 3 bar pressure drop curves. Interpolate the point which gives 2,3 bar.
- If this is acceptable the valve can be used.

E.g. Maximum flow.

Valve size is 1"
HPR = 3 bar
Maximum ΔP = 2 bar
What is maximum Q?

Solution:

- Draw a horizontal line at 3 bar HPR (scale B) till intersection with 2 bar delta P curve.
- Draw a vertical line from this intersection point to the 1" valve curve.
- Draw from this point a horizontal line to the water flow scale A.
You find 9 m³/h.

Valve size selection by the use of the K_v factors and calculation formulae

For water:

The following K_v values can be used:

$$K_v = \frac{Q}{\sqrt{\Delta p}}$$

$$\Delta P = \left(\frac{Q}{K_v} \right)^2$$

$$Q = K_v \cdot \sqrt{\Delta p}$$

Valve size	K _v value
------------	----------------------

3/8"	1.8
1/2"	2.7
3/4"	4.5
1"	6.5
1 1/4"	9
1 1/2"	10.5
2"	18 (low range)
2"	17 (high range)
2 1/2"	22 (low range)
2 1/2"	20 (high range)

Q = quantity of liquid (in m³/h)
 ΔP = pressure drop across valve (in bar)
K_v = valve flow coefficient

The K_v factor is the quantity of 20°C water that will pass through the valve at one bar pressure drop and a valve opening which belongs by 3 bar head pressure rise (HPR) above the valve opening point.

Diagram for selecting the valve size corresponding with information on page 3

Note: Use dotted curves for high range 2" and 2½" valves

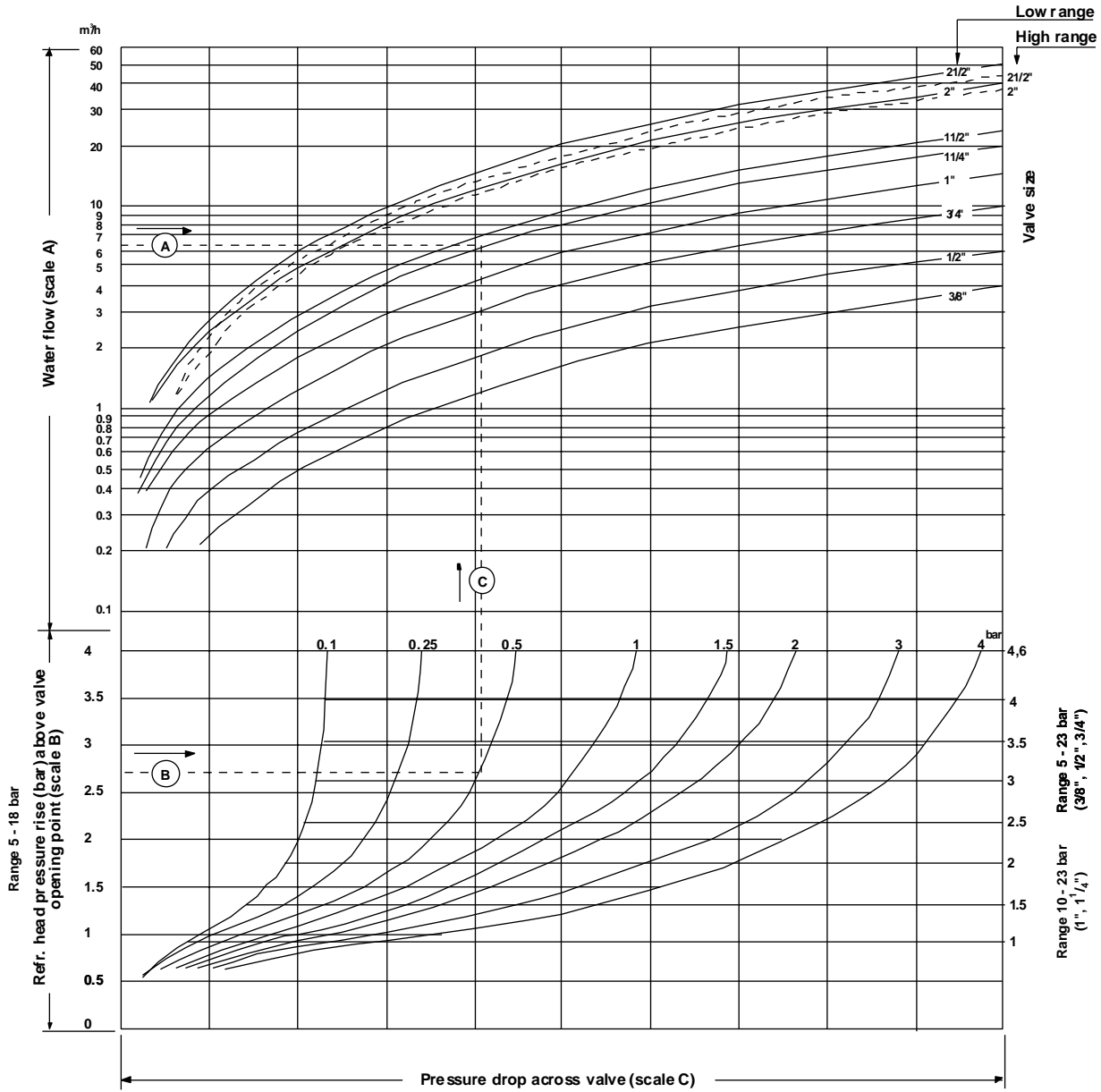

Note: 1 dm³/s = 3.6 m³/h = 15.8 U.S. gal./min. = 13.2 U.K. gal./min.
 1 bar = 100 kPa = 0.1 MPa ≈ 1.02 kp/cm² = 1.02 at ≈ 14.5 psi.

Fig. 1

Ammonia (NH₃) applications

For all larger valve types an ammonia element is available. These elements have style 15 pressure connection and consist of a stainless steel bellow in a steel cup (coated). The existing element can be replaced by this ammonia element. The pressure range does not change. For the high range valves (V46AS/AT/BS/BT) the spring inside the power element has to be placed in the ammonia element. If low pressure is needed this spring can be removed. For low quantities you have to order the selected valve and separate ammonia replacement power element (see valve type selection table). For quantity orders a special valve type can be set up. Then please contact the JC sales office in your region.

Repair and replacement

Diaphragm kits can be ordered for all valves. Also the complete power element can be replaced. For a total revision of the valve a renewal kit can be ordered.

For type numbers of replacement power elements, renewal kits and diaphragm kits see valve selection table.

If a replacement is ordered a "repair parts and service instruction" sheet will be included in which a step by step description is given to disassemble/assemble the valve.

Renewal KITS

Each KIT contains parts as indicated in the table below. The complete KIT must be ordered that contains part required.		Disc cup	Valve disc	Plunger disc	Seat guide	Disc stud	Valve stem	Valve disc holder	Extension sleeve	Valve seat	Diaphragms	Gasket	Valve seat wrench	Screw	Seal ring
Valve type:	KIT number:														
V46AA	STT002N600R	1	1	-	1	1	1	-	-	1	4	1	1	-	1
V46AB	STT003N600R	1	1	-	1	1	1	-	-	1	4	1	1	-	1
V46AC	STT004N600R	1	1	-	1	1	1	-	-	1	4	1	1	-	1
V46AD	STT17A609R	1	1	-	1	1	1	-	-	1	5	1	1	-	1
V46AE	STT17A610R	1	1	-	1	1	1	-	-	1	5	1	1	-	1
V46AR	STT17A610R	1	1	-	1	1	1	-	-	1	5	1	1	-	1
V46AS	STT18A600R	-	1	1	-	-	-	1	1	1	5	1	-	1	1
V46AT	STT18A601R	-	1	1	-	-	-	1	1	1	5	1	-	1	1
V46BA	STT14A601R	1	1	-	1	1	1	-	-	1	4	-	1	-	-
V46BB	STT15A603R	1	1	-	1	1	1	-	-	1	4	-	1	-	-
V46BC	STT17A613R	1	1	-	1	1	1	-	-	1	4	-	1	-	-
V46BD	STT17A611R	1	1	-	1	1	1	-	-	1	5	-	1	-	-
V46BE	STT17A612R	1	1	-	1	1	1	-	-	1	5	-	1	-	-
V46BR	STT17A612R	1	1	-	1	1	1	-	-	1	5	-	1	-	-
V46BS	STT18A602R	-	1	1	-	-	-	1	1	1	5	-	-	1	-
V46BT	STT18A602R	-	1	1	-	-	-	1	1	1	5	-	-	1	-

Pressure connections

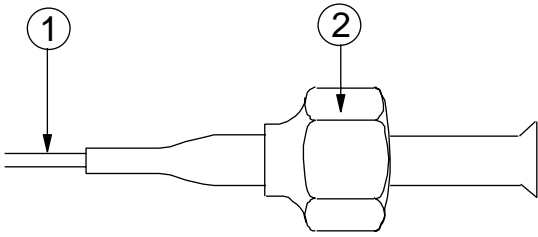

Fig. 2
Style 13 (excl. valve depressor)

- 1. 75 cm capillary
- 2. 7/16-20 UNF flare nut

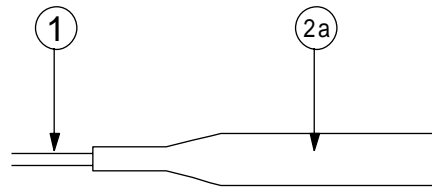

Fig. 3
Style 34

- 1. 75 cm capillary
- 2. 1/4" tube for braze connection

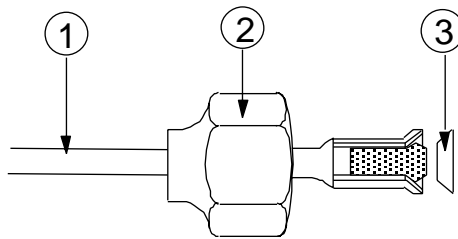

Fig. 4
Style 50 (incl. valve depressor mounted into machined flare)

- 1. 75 cm capillary.
- 2. 7/16 - 20 UNF flare nut.
- 3. copper sealring

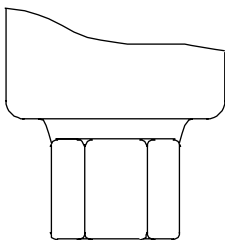

Fig. 5
Style 15
1/4-18NPT (female)

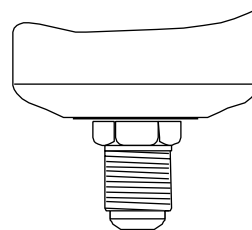

Fig. 6
Style 5
7/16-20 UNF

Dimensions (mm)

For valve type see specifications page 11

Angled type

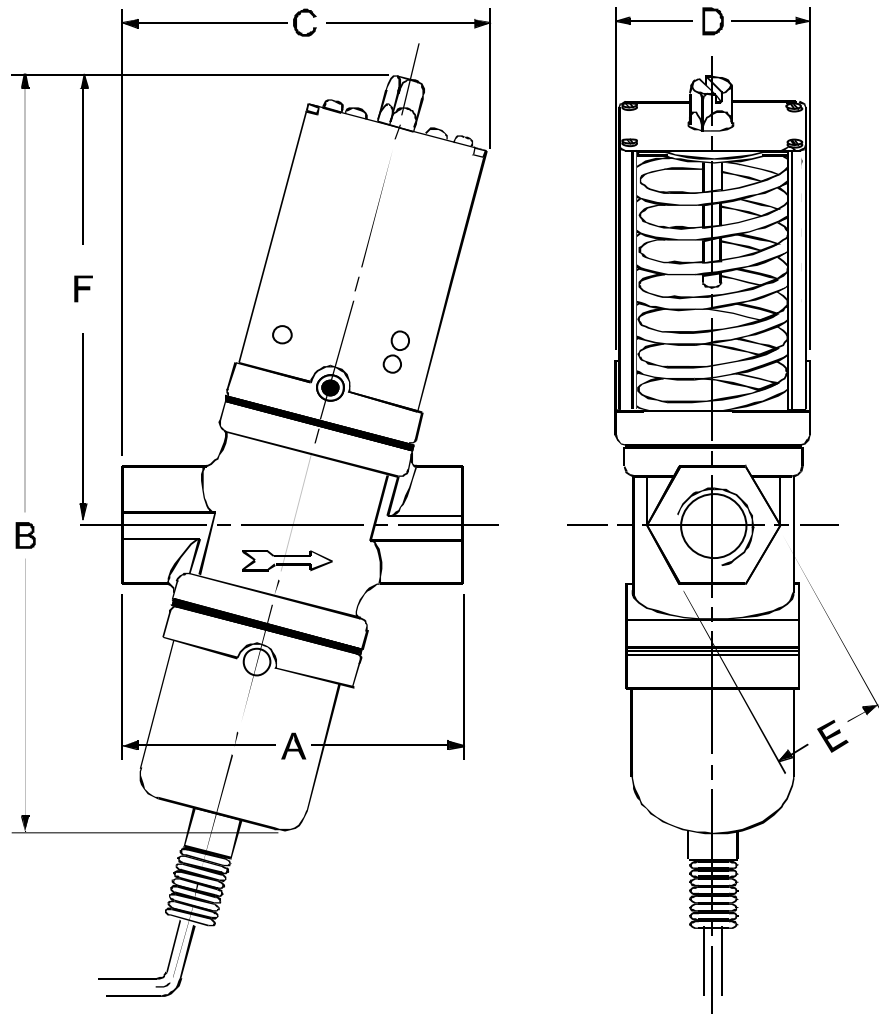

Fig. 7

Commercial Types

Valve type	Valve size	Dimensions in mm					
		A	B	C	D	E	F
V46AA	3/8"	69	153	66	43	18	89
V46AB	1/2"	80	170	86	51	27	100
V46AC	3/4"	91	183	95	55	36	110

Dimensions (mm)

For valve type see specifications page 11

Straight type

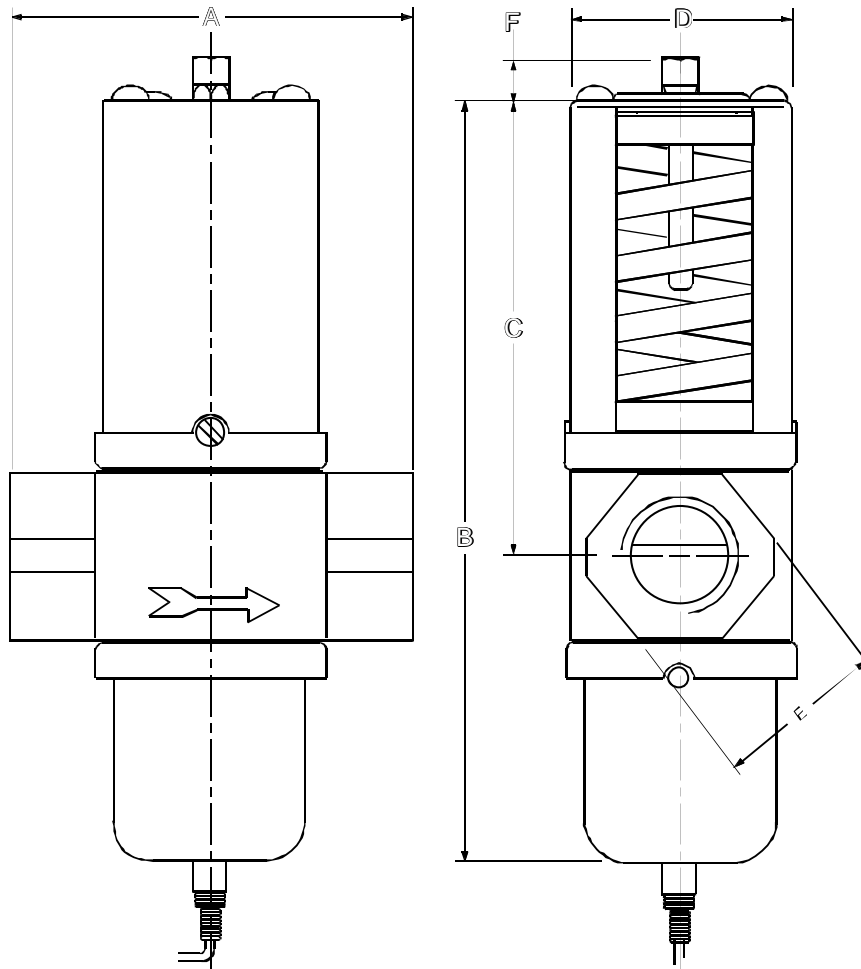

Fig. 8

Commercial Types

Valve type	Valve size	Dimensions in mm.					
		A	B	C	D	E	F
V46AD	1"	124	233	139	72	50	13
V46AE	1 1/4"	125	243	145	72	58	13

Sea-water Types

V46BA	3/8"	68	161	80	42	32	10
V46BB	1/2"	79	165	86	52	29	10
V46BC	3/4"	86	175	96	55	35	10
V46BD	1"	124	246	139	71	52	13
V46BE	1 1/4"	124	254	144	71	62	13

Dimensions (mm)

For valve type see specifications page 11

Flange type

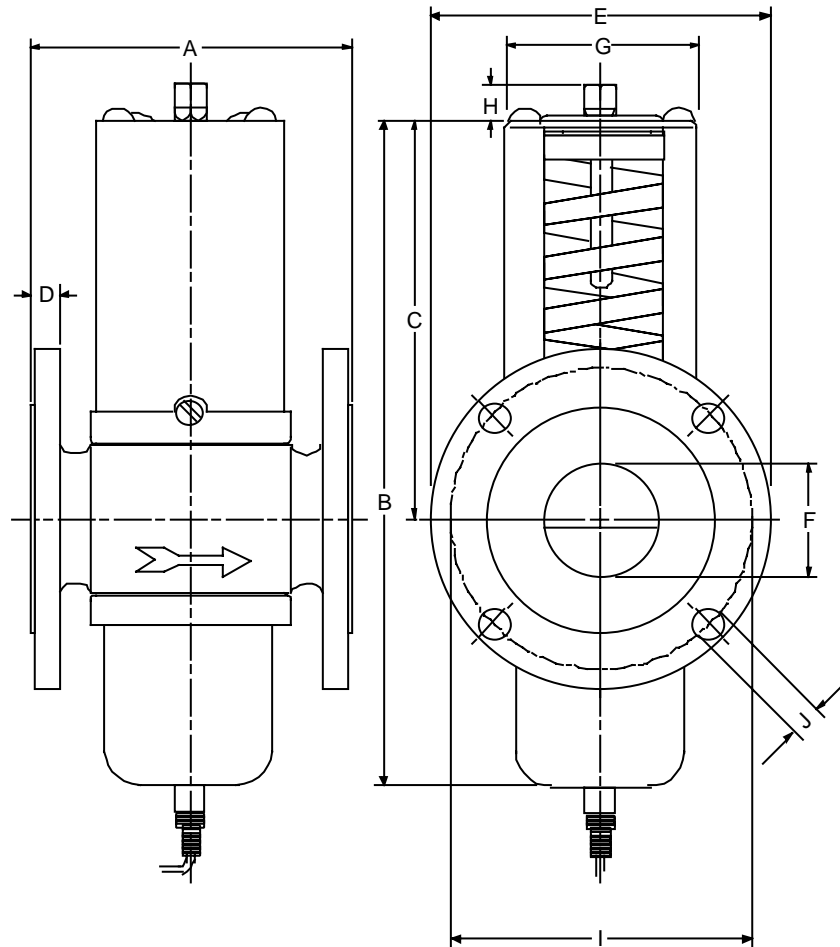

Fig. 9

Commercial Types

Valve type	Valve size	Dimensions in mm.									
		A	B	C	D	E	F	G	H	I	J
V46AR	1½"	137	244	144	18	150	47	67	13	110	18
V46AS	2"	168	304	164	20	165	57	90	18	125	18
V46AT	2½"	172	304	164	20	185	70	90	18	145	18

Sea-water Types

V46BR	1½"	135	244	144	14	150	47	67	13	110	18
V46BS	2"	162	304	164	16	165	57	90	18	125	18
V46BT	2½"	172	304	164	16	185	70	90	18	145	18

Valve selection table

Commercial types

Item	Size inch	Range bar	Refrig. connec. Style	Capil. length m	Connection thread/flange	Replacements			Ammonia element type	Weight single pack kg.	Qty per box	Weight per box kg.
						power element	renewal kit	diaphragm kit				
V46AA-9300	3/8	5/23	5	-	ISO 228 - G ³ / ₈	246-672R	STT002N600R	KIT016N600 (100)	-	0.9	24	22.0
V46AA-9301	3/8	5/23	5	-	ISO 228 - G ³ / ₈	246-672R	STT002N600R	KIT016N600 (100)	-	0.9	24	22.0
V46AA-9510	3/8	5/23	50	0.75	ISO 228 - G ³ / ₈	-	STT002N600R	KIT016N600 (100)	-	0.9	24	22.0
V46AA-9511	3/8	5/23	51	1.2	ISO 228 - G ³ / ₈	-	STT002N600R	KIT016N600 (100)	-	0.9	24	22.0
V46AA-9600	3/8	5/18	13	0.75	ISO 228 - G ³ / ₈	246-821R	STT002N600R	KIT016N600 (100)	-	0.9	24	22.0
V46AA-9602*	3/8	5/18	13	1.00	ISO 228 - G ³ / ₈	-	STT002N600R	KIT016N600 (100)	-	0.9	24	22.0
V46AA-9606*	3/8	5/23	13	0.75	ISO 228 - G ³ / ₈	246-821R	STT002N600R	KIT016N600 (100)	-	0.9	24	22.0
V46AA-9620	=	Bulkpack V46AA-9600									24	22.0
V46AA-9950*	3/8	5/18	34	0.75	ISO 228 - G ³ / ₈	-	STT002N600R	KIT016N600 (100)	-	0.9	24	22.0
V46AB-9300	1/2	5/23	5	-	ISO 228 - G ¹ / ₂	246-673R	STT003N600R	KIT016N601 (100)	-	1.3	18	24.0
V46AB-9510	1/2	5/23	50	0.75	ISO 228 - G ¹ / ₂	-	STT003N600R	KIT016N601 (100)	-	1.3	18	24.0
V46AB-9600	1/2	5/18	13	0.75	ISO 228 - G ¹ / ₂	246-824R	STT003N600R	KIT016N601 (100)	-	1.3	18	24.0
V46AB-9605*	1/2	5/23	13	0.75	ISO 228 - G ¹ / ₂	246-824R	STT003N600R	KIT016N601 (100)	-	1.3	18	24.0
V46AB-9950	1/2	5/18	34	0.75	ISO 228 - G ¹ / ₂	-	STT003N600R	KIT016N601 (100)	-	1.3	18	24.0
V46AB-9951*	1/2	5/23	34	0.75	ISO 228 - G ¹ / ₂	-	STT003N600R	KIT016N601 (100)	-	1.3	18	24.0
V46AC-9300	3/4	5/23	5	0.75	ISO 228 - G ³ / ₄	246-674R	STT004N600R	KIT016N602 (100)	-	1.7	14	25.5
V46AC-9510	3/4	5/23	50	0.75	ISO 228 - G ³ / ₄	-	STT004N600R	KIT016N602 (100)	-	1.7	14	25.5
V46AC-9600	3/4	5/18	13	0.75	ISO 228 - G ³ / ₄	246-825R	STT004N600R	KIT016N602 (100)	-	1.7	14	25.5
V46AC-9605*	3/4	5/23	13	0.75	ISO 228 - G ³ / ₄	246-825R	STT004N600R	KIT016N602 (100)	-	1.7	14	25.5
V46AC-9606	3/4	5/18	13	1.20	ISO 228 - G ³ / ₄	-	STT004N600R	KIT016N602 (100)	-	1.7	14	25.5
V46AC-9951	3/4	5/18	34	0.75	ISO 228 - G ³ / ₄	-	STT004N600R	KIT016N602 (100)	-	1.7	14	25.5
V46AD-9300	1	5/18	5	-	ISO 7 - Rc 1	246-675R	STT17A609R	KIT016N603 (50)	246-667R	3.5	1	3.5
V46AD-9510	1	5/18	50	0.75	ISO 7 - Rc 1	-	STT17A609R	KIT016N603 (50)	246-667R	3.5	1	3.5
V46AD-9511	1	10/23	50	0.75	ISO 7 - Rc 1	-	STT17A609R	KIT016N603 (50)	246-667R	3.5	1	3.5
V46AD-9600	1	5/18	13	0.75	ISO 7 - Rc 1	246-925R	STT17A609R	KIT016N603 (50)	246-667R	3.5	1	3.5
V46AE-9300	1 1/4	5/18	5	-	ISO 7 - Rc 1 1/4	246-675R	STT17A610R	KIT016N603 (50)	246-667R	3.8	1	3.8
V46AE-9510	1 1/4	5/18	50	0.75	ISO 7 - Rc 1 1/4	-	STT17A610R	KIT016N603 (50)	246-667R	3.8	1	3.8
V46AE-9512	1 1/4	10/23	50	0.75	ISO 7 - Rc 1 1/4	-	STT17A610R	KIT016N603 (50)	246-667R	4.0	1	3.8
V46AE-9513	1 1/4	10/23	50	1.50	ISO 7 - Rc 1 1/4	-	STT17A610R	KIT016N603 (50)	246-667R	4.0	1	3.8
V46AE-9600	1 1/4	5/18	13	0.75	ISO 7 - Rc 1 1/4	246-925R	STT17A610R	KIT016N603 (50)	246-667R	3.8	1	3.8
V46AE-9700	1 1/4	7/14	15	-	ISO 7 - Rc 1 1/4	246-667R	STT17A610R	KIT016N603 (50)	246-667R	3.8	1	3.8
V46AE-9950	1 1/4	5/18	34	1.30	ISO 7 - Rc 1 1/4	-	STT17A610R	KIT016N603 (50)	-	3.8	1	3.8
V46AR-9300	1 1/2	5/18	5	-	Flange 1 1/2 DIN2533	246-675R	STT17A610R	KIT016N603 (50)	246-667R	7.5	1	7.5
V46AR-9600	1 1/2	5/18	13	0.75	Flange 1 1/2 DIN2533	246-925R	STT17A610R	KIT016N603 (50)	246-667R	7.5	1	7.5
V46AR-9700	1 1/2	7/14	15	-	Flange 1 1/2 DIN2533	246-667R	STT17A610R	KIT016N603 (50)	246-667R	7.5	1	7.5
V46AS-9300	2	5/11.5	5	-	Flange 2 DIN2533	246-671R	STT18A600R	KIT016N604 (25)	246-781R	13.0	1	13.0
V46AS-9301	2	11/18	5	-	Flange 2 DIN2533	246-758R	STT18A600R	KIT016N604 (25)	246-781R	13.0	1	13.0
V46AS-9700	2	7/14	15	-	Flange 2 DIN2533	246-781R	STT18A600R	KIT016N604 (25)	246-781R	13.0	1	13.0
V46AT-9300	2 1/2	5/11.5	5	-	Flange 2 1/2 DIN2533	246-671R	STT18A601R	KIT016N604 (25)	246-781R	14.0	1	14.0
V46AT-9301	2 1/2	11/18	5	-	Flange 2 1/2 DIN2533	246-758R	STT18A601R	KIT016N604 (25)	246-781R	14.0	1	14.0
V46AT-9700	2 1/2	7/14	15	-	Flange 2 1/2 DIN2533	246-781R	STT18A601R	KIT016N604 (25)	246-781R	14.0	1	14.0

* nickel plated seat

Sea-water types

Item	Size inch	Range bar	Refrig. connec. style	Capil. length m	Connection thread/flange	Replacements			Ammonia element type	Weight single pack kg.	Qty per box	Weight per box kg.
						power element	renewal kit	diaphragm kit				
V46BA-9510	3/8	5/23	50	0.75	ISO 228 - G ³ / ₈	-	STT14A601R	KIT016N600 (100)	-	0.8	24	20.0
V46BA-9600	3/8	5/18	13	0.75	ISO 228 - G ³ / ₈	246-821R	STT14A601R	KIT016N600 (100)	-	0.8	24	20.0
V46BB-9510	1/2	5/23	50	0.75	ISO 228 - G ¹ / ₂	-	STT15A603R	KIT016N601 (100)	-	1.3	18	24.0
V46BB-9600	1/2	5/18	13	0.75	ISO 228 - G ¹ / ₂	246-824R	STT15A603R	KIT016N601 (100)	-	1.3	18	24.0
V46BC-9510	3/4	5/23	50	0.75	ISO 228 - G ³ / ₄	-	STT17A613R	KIT016N602 (100)	-	1.7	14	25.0
V46BC-9511	3/4	5/23	50	1.40	ISO 228 - G ³ / ₄	-	STT17A613R	KIT016N602 (100)	-	1.7	14	25.0
V46BC-9600	3/4	5/18	13	0.75	ISO 228 - G ³ / ₄	246-825R	STT17A613R	KIT016N602 (100)	-	1.7	14	25.0
V46BC-9601	3/4	5/18	13	1.20	ISO 228 - G ³ / ₄	-	STT17A613R	KIT016N602 (100)	-	1.7	14	25.0
V46BD-9510	1	10/23	50	0.75	ISO 228 - G1	-	STT17A611R	KIT016N603 (50)	246-667R	4.0	1	4.0
V46BD-9600	1	5/18	13	0.75	ISO 228 - G1	246-925R	STT17A611R	KIT016N603 (50)	246-667R	4.0	1	4.0
V46BD-9601	1	5/18	13	1.20	ISO 228 - G1	-	STT17A611R	KIT016N603 (50)	246-667R	4.0	1	4.0
V46BE-9510	1 1/4	5/18	50	0.75	ISO 228 - G1 1/4	-	STT17A612R	KIT016N603 (50)	246-667R	4.5	1	4.5
V46BE-9511	1 1/4	10/23	50	1.50	ISO 228 - G1 1/4	-	STT17A612R	KIT016N603 (50)	246-667R	4.5	1	4.5
V46BE-9600	1 1/4	5/18	13	0.75	ISO 228 - G1 1/4	246-925R	STT17A612R	KIT016N603 (50)	246-667R	4.5	1	4.5
V46BE-9601	1 1/4	5/18	13	1.20	ISO 228 - G1 1/4	-	STT17A612R	KIT016N603 (50)	246-667R	4.5	1	4.5
V46BR-9510	1 1/2	5/18	50	0.75	Flange 1 1/2 DIN86021	-	STT17A612R	KIT016N603 (50)	246-667R	7.5	1	7.5
V46BR-9600	1 1/2	5/18	13	0.75	Flange 1 1/2 DIN86021	246-925R	STT17A612R	KIT016N603 (50)	246-667R	7.5	1	7.5
V46BS-9300	2	5/11.5	5	-	Flange 2 DIN86021	246-758R	STT18A602R	KIT016N604 (25)	246-781R	13.5	1	13.5
V46BS-9301	2	11/18	5	-	Flange 2 DIN86021	246-758R	STT18A602R	KIT016N604 (25)	246-781R	13.5	1	13.5
V46BT-9300	2 1/2	5/11.5	5	-	Flange 2 1/2 DIN86021	246-758R	STT18A602R	KIT016N604 (25)	246-781R	14.5	1	14.5
V46BT-9301	2 1/2	11/18	5	-	Flange 2 1/2 DIN86021	246-758R	STT18A602R	KIT016N604 (25)	246-781R	15.0	1	15.0
V46BT-9700	2 1/2	7/14	15	-	Flange 2 1/2 DIN86021	246-781R	STT18A602R	KIT016N604 (25)	246-781R	15.0	1	15.0

Specifications

Commercial

	Size	3/8" - 3/4"	1" - 1 1/4"	1 1/2"	2" - 2 1/2"	2" - 2 1/2"
Operating range (bar)		5-18 / 5-23	5-18 / 10-23	5-18	5-11,5	11-18
Max. refrig. overrun press. (bar)		28	28	28	28	28
Max. water supply press. (bar)		10	10	10	10	10
Max. water supply temp.		90 °C	90 °C	90 °C	90 °C	90 °C
Min. water supply temp.*		-20 °C	-20 °C	-20 °C	-20 °C	-20 °C
Valve hysteresis (bar)		~ 0,5	~ 0,5	~ 0,5	~ 0,5	~ 0,5
Valve body style	angled	x				
	straight		x	x	x	x
Pipe connection**	thread ISO 228	x				
	thread ISO 7 - Rc		x			
	flange DIN 2533			x	x	x
Material	body	hot forged brass	cast iron***	cast iron***	cast iron***	cast iron***
	disc stud/disc cup	brass	brass	brass	brass	brass
	seat	alum. bronze	alum. bronze	alum. bronze	alum. bronze	alum. bronze
	diaphragms	BUNA-N	BUNA-N	BUNA-N	BUNA-N	BUNA-N
	bellows	ph. bronze	ph. bronze	ph. bronze	tombac	monel
	stem/extension sleeve	brass	brass	brass	brass	brass
	disc	BUNA-N	BUNA-N	BUNA-N	BUNA-N	BUNA-N

Sea-water

	Size	3/8" - 3/4"	1" - 1 1/4"	1 1/2"	2" - 2 1/2"	2" - 2 1/2"
Operating range (bar)		5-18 / 5-23	5-18 / 10-23	5-18	5-11,5	11-18
Max. refrig. overrun press. (bar)		28	28	28	28	28
Max. water supply press. (bar)		10	10	10	10	10
Max. water supply temp.		90 °C	90 °C	90 °C	90 °C	90 °C
Min. water supply temp.*		-20 °C	-20 °C	-20 °C	-20 °C	-20 °C
Valve hysteresis (bar)		~ 0,5	~ 0,5	~ 0,5	~ 0,5	~ 0,5
Valve body style	straight	x	x	x	x	x
Pipe ** connection	thread ISO 228	x	x			
	flange DIN86021			x	x	x
Material	body	bronze	bronze	bronze	bronze	bronze
	disc stud/disc cup	monel	monel	monel	monel	monel
	seat	monel	monel	monel	monel	monel
	diaphragms	BUNA-N	BUNA-N	BUNA-N	BUNA-N	BUNA-N
	bellows	ph. bronze	ph. bronze	ph. bronze	monel	monel
	stem/extension sleeve	monel	monel	monel	monel	monel
	disc	BUNA-N	BUNA-N	BUNA-N	BUNA-N	BUNA-N
Pressure connection style		See selection table.				
Capillary length		See selection table.				
Ammonia element style 15 press. connection		Stainless steel bellow in steel cup.				
Shipping weights		See valve selection table.				

* Care should be taken the valve does not freeze up.
 ** Thread ISO 7 - Rc = DIN2999-RC thread/ISO 228 = DIN259-Rp thread
 *** Cast iron bodies are executed with rust resisting finish

The performance specifications are nominal and conform to acceptable industry standards. For application at conditions beyond these specifications, consult the local Johnson Controls office. Johnson Controls, Inc. shall not be liable for damages resulting from misapplication or misuse of its products.



Johnson Controls International, Inc.

Headquarters: Milwaukee, Wisconsin, USA
 European Customer Service Center: Westendhof 3, D-45143 Essen, Germany
 European Factories: Essen (Germany), Leeuwarden (The Netherlands) and Lomagna (Italy)
 Branch Offices: Principal European Cities.
 This document is subject to change

www.johnsoncontrols.com
 Printed in Europe

PRODUCT BULLETIN

Series V46SA

Pressure Actuated "Low Flow" Water Regulating Valve

Introduction

The V46SA is a direct acting, "all range", pressure actuated modulating valve, used to control the waterflow to a condenser by directly sensing pressure changes in a non-corrosive refrigerant circuit. The V46SA is specially designed for use on equipment requiring a low condenser waterflow such as icemakers, small heatpumps and watercoolers.

The springhousing and power element are rolled to the valve body.

Rubber diaphragms seal the water away from the range spring and bellows part so these are not submerged in water where they would be subject to sedimentation and corrosion.

The valve can be ordered style 5 (without capillary), style 13, style 34 and style 50 (incl. 75 cm capillary).

The capillary part will be delivered separated from the valve.



V46SA Pressure Actuated "Low Flow,"
Water Regulating Valve

Feature and Benefits

<input type="checkbox"/> Valve designed for low flow.	Designed to prevent cavitation and water hammer at low water flow applications.
<input type="checkbox"/> "All range" power element and spring housing.	Reduces stock. Only one valve for all non-corrosive refrigerants.
<input type="checkbox"/> Small dimensions.	Easy to fit in "small dimension" equipment.
<input type="checkbox"/> Pressure actuated	Fast response to pressure increase.
<input type="checkbox"/> Various pressure connection styles.	Possibility to meet the legislation in your country.
<input type="checkbox"/> High refrigerant pressure resistant bellows.	Refrigerant pressure may increase up to 28 bar without bellow damage.

Note

All series V46 water regulating valves are designed for use only as operating devices. Where system closure, improper flow or loss of pressure due to valve failure can result in personal injury and/or loss of property, a separate pressure relief or safety shut off valve, as applicable must be added by the user.

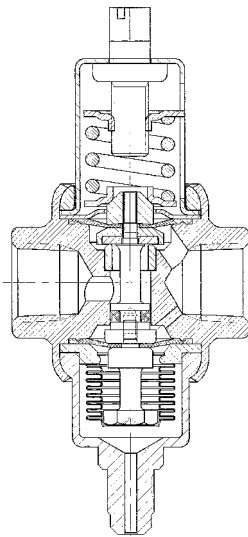

Fig. 1
Cross-Section of V46SA

Mounting

Style 5 valves may be mounted in any position. For capillary types it is recommended that the pressure connection be made below the mounting plane of the valve to minimize the possibility of slow response due to oil accumulating in the capillary.

Adjustment

The pressure at which the valve starts to open (opening point) can be adjusted by the adjusting screw located at the top of the spring housing. Clockwise will lower and counter clockwise will raise the opening point (Valve is not factory set at a certain value).

Valve Capacity

The valve capacity is determined by three data:

1. The required max. flow.
2. The max. allowed pressure drop across the valve ($= \Delta p$ bar).
3. The head pressure rise which is the difference between the pressure where the valve starts to open and the condenser operating pressure ($= HPR$).

The valve operating conditions can be determined by use of the flow diagram or K_v calculation formulae.

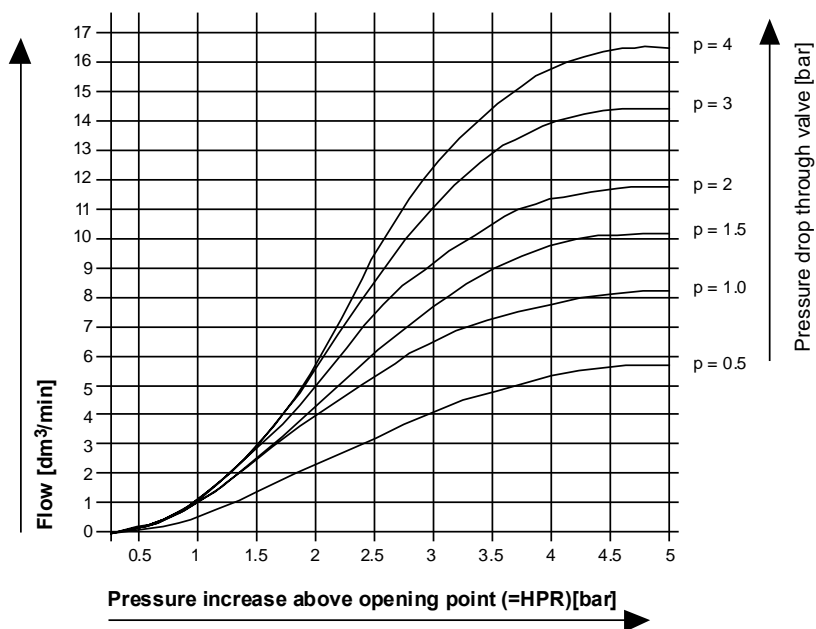

Fig. 2
Flow Diagram

For water the following formulae can be used to calculate the quantity of water (Q in m³/h) or the pressure drop across the valve (Δp in bar).

$$K_v = \frac{Q}{\sqrt{\Delta p}} \quad \Delta p = \left(\frac{Q}{K_v}\right)^2 \quad Q = K_v \cdot \sqrt{\Delta p}$$

The (V46SA) K_v -value= 0.5

The K_v factor is the quantity of 20°C water that will pass through the valve at one bar pressure drop and maximum valve opening.

Note

If the compressor operates in a high ambient temperature, the refrigerant pressure may at times remain high enough to cause the valve to partly open when the compressor is idle. In such conditions the valve opening point should be raised just enough to cause the valve to close during compressor standby periods. Take this into account when flow is calculated..

Pressure Connections

In the valve selection table the following connection styles are given.

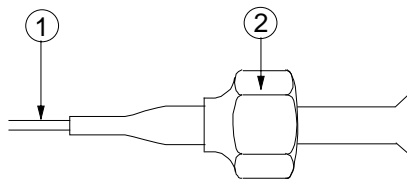

Fig. 3
Style 13 (excl. valve depressor)

1. 75 cm capillary
2. 7/16-20 UNF flare nut

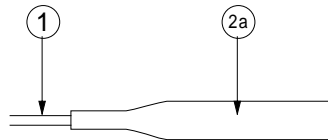

Fig. 4
Style 34

1. 75 cm capillary
2. 1/4" tube for braze connection

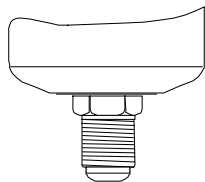

Fig. 5
Style 5
7/16-20 UNF

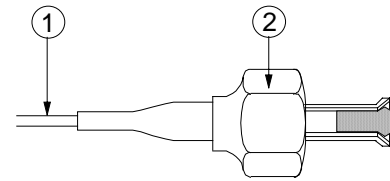

Fig. 6
Style 45A (incl. valve depressor mounted into flare)

1. 75 cm capillary.
2. 7/16 - 20 UNF flare nut.

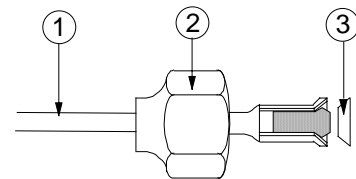

Fig. 7
Style 50 (incl. valve depressor mounted into machined flare)

1. 75 cm capillary.
2. 7/16 - 20 UNF flare nut.
3. copper sealing

Type Number Selection Table

V46SA-9101	75 cm capillary style 45A soldered to power element
V46SA-9110	75 cm capillary style 50 (separate)
V46SA-9111	Nickel plated seat, 75 cm capillary style 50 (separate)
V46SA-9300	Style 5
V46SA-9600	75 cm capillary style 13 (separate)
V46SA-9950	75 cm capillary style 34 (separate)
V46SA-9951	75 cm capillary style 34 soldered to power element

Repair and Replacement

Repair is not possible. In case of an improperly functioning control, please check with your nearest supplier. When contacting the supplier for a replacement you should state the type-model number which can be found on the data plate.

Dimensions

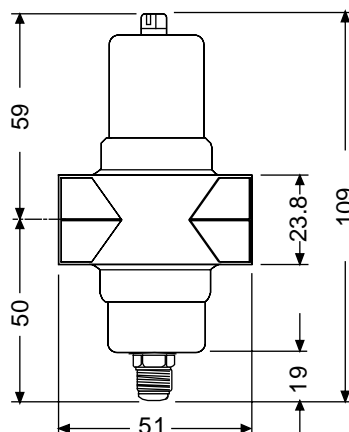

Fig. 7

Specifications

Size	3/8"
Control action	direct (open on pressure increase)
Operating pressure range	5-23 bar (non-corrosive refr.)
Max. refig. overrun pressure	28 bar
Max. water pressure	23 bar
Operating water pressure max.	10 bar
Max. Δp across valve	6 bar
Max. water supply temp.	90°C
Min. water supply temp.	-20°C (care should be taken, the valve does not freeze up)
Valve hysteresis	≈ 2.5 bar at 10 bar setting
K_v value	0.5
Pipe connection	ISO 228 (ISO 228 = DIN 259-Rp = BSPP)
Pressure connections	Style 5 Style 13 incl. 75 cm capillary Style 50 incl. 75 cm capillary Style 34 incl. 75 cm capillary Style 45A incl. 75 cm capillary
Materials	body : brass seat : alum. bronze disc : BUNA-N disc cup : brass stem : brass diaphragms : BUNA-N bellows : phosphor bronze bellows cup : brass
Package	individual pack
Weight	0,45 kg

The performance specifications are nominal and conform to acceptable industry standards. For applications at conditions beyond these specifications, consult the local Johnson Controls office or representative. Johnson Controls shall not be liable for damages resulting from misapplication or misuse of its products.



Johnson Controls International, Inc.

Headquarters: Milwaukee, WI, USA
 European Headquarters: Brussels, Belgium
 European Factories: Lomagna (Italy), Leeuwarden (The Netherlands) and Essen (Germany)
 Branch Offices: Principal European Cities.

This document is subject to change

www.johnsoncontrols.com
 Printed in Europe

Series V47

Temperature Actuated Modulating Valves

Introduction

The V47 modulating water valves regulate the flow of water to maintain a desired temperature. The valves have a quick opening characteristic and OPEN on a temperature increase at the bulb.

The V47 temperature valves are used for heating applications. It has a heating element, this means that the bulb temperature always must be higher than that of the valve body (the power element).



Series V47
Temperature Actuated Water Regulating Valve

Feature and Benefits	
<input type="checkbox"/> Pressure balanced valve design	Setpoint is independent from water inlet pressure
<input type="checkbox"/> 3/8, 1/2, 3/4" are angled body type valves with high Kv value	Small dimensions with high flow capacity
<input type="checkbox"/> No close fitting or sliding parts in water passages	No hysteresis increase or stuck valve caused by contamination
<input type="checkbox"/> Easy to disassemble. All parts can be replaced	Valve can easily be repaired "in line". Valve piece parts are available "world-wide"
<input type="checkbox"/> Special bronze bodies and monel parts	Used for sea water applications

Note

All Series V47 water regulating valves are designed for use only as operating devices. Where system closure, improper flow or loss of pressure due to valve failure can result in personal injury and/or loss of property, a separate pressure relief or safety shutoff valve, as applicable, must be added by the user.

Description

A pressure-balanced design employing rubber sealing diaphragms correctly proportioned to the valve port area, balances valve against both gradual and sudden water pressure changes, and seals water away from range spring, guides and sliding parts so these are not submerged in water where they would be subject to sedimentation and corrosion. Only five metal parts, made of corrosion resistant material, come in contact with the water. These are the valve disc holder, the disc stud, the valve seat, the valve stem, and the body.

Adjustments

The temperature at which the valve starts to open (= opening point) can be adjusted by the adjusting screw located at the top of the range spring housing. Valves may be adjusted with standard service valve wrenches or screwdrivers. (Valves are not factory set at a certain value.)

Manual flushing

Valves may be manually flushed by lifting the lower spring guide with screwdrivers at two sides of the pressure plate to open valve. This does not affect valve adjustment.

Valve size selection

The valve size can be selected by the use of:

- the diagram (see page 3).
- K_V factors and calculation formulae

Refer to the Diagram for selection of valves sizes. Carefully follow the steps as outlined below.

1. Determine the maximum water flow required and draw a horizontal line across upper half of Flow Chart through this flow (e.g. 65 l/min, see line A)
2. Determine the temperature rise above the valve opening point.
 - a. Valve closing point is the lowest temperature at which it is desired to have no flow through the valve.

- b. Valve opening point will be about 3 K above the valve closing point.
 - c. Determine the temperature the valve is to maintain.
 - d. Subtract the temperature opening point from the operating temperature. This gives the temperature rise.
3. Draw a horizontal line across lower half of Flow Chart through this value (e.g. 8 K, see line B)
4. Determine the allowable pressure drop through the valve. This is the pressure actually available to force liquid through the valve.
5. On lower half of curve, mark point on drawn-in horizontal temperature line at pressure determined in Step 4 (e.g. Δp of 2 bar, see line B). Interpolate between curves, or pick curve for nearest lower pressure drop for which curve is drawn (this gives a reserve maximum load capacity).
6. From this point draw line vertically upward until it intersects drawn-in horizontal water flow line in upper half of Flow Chart (see line C).
7. If intersection falls on a valve size curve this is the valve size.
8. If intersection falls between two curves the required valve size is the larger of the two (for given example it becomes a 1" valve) .

Valve size selection by the use of the K_V factors and calculation formulae

For water:

$$K_V = \frac{Q}{\sqrt{p}}$$

$$\Delta P = \left(\frac{Q}{K_V} \right)^2$$

$$Q = K_V \cdot \sqrt{p}$$

Q = quantity of liquid (in m³/h)

ΔP = pressure drop across valve (in bar)

K_V = valve flow coefficient

The K_V factor is the quantity of 20°C water that will pass through the valve at one bar pressure drop and a valve opening which belongs by 14 K temperature rise above the valve opening point.

The following K_V values can be used:

Valve size	K_V value
3/8"	1.8
1/2"	2.7
3/4"	4.5
1"	6.5
1 1/4"	9
1 1/2"	10.5
2"	18
2 1/2"	22

Diagram for selecting the valve size corresponding with information on page 2

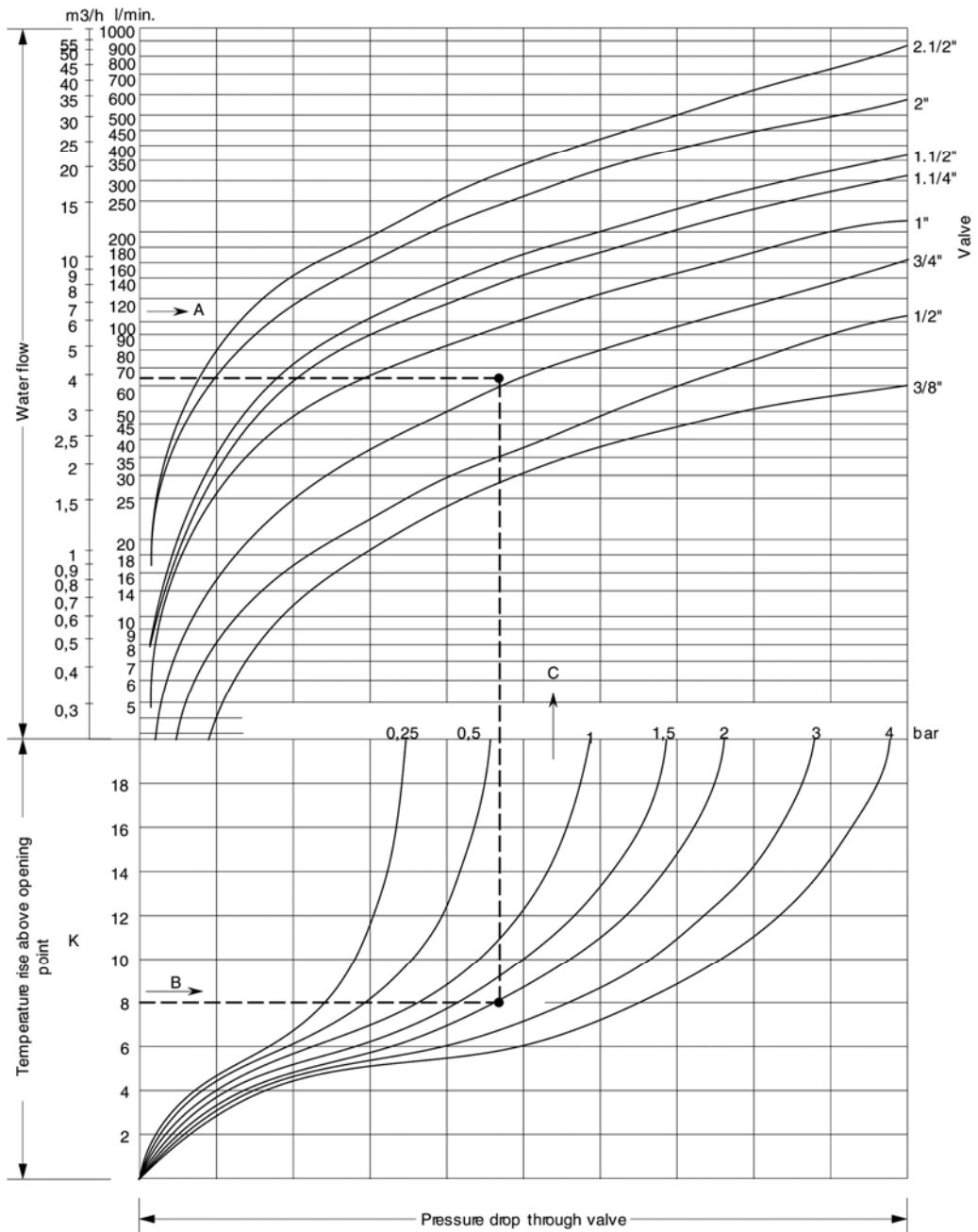

Note: $1 \text{ dm}^3/\text{s} = 3.6 \text{ m}^3/\text{h} = 15.8 \text{ U.S. gal./min.} = 13.2 \text{ U.K. gal./min.}$
 $1 \text{ bar} = 100 \text{ kPa} = 0.1 \text{ MPa} \approx 1.02 \text{ kp/cm}^2 = 1.02 \text{ at} \approx 14.5 \text{ psi.}$

Fig. 1

Repair and replacement

Diaphragm kits can be ordered for all valves. Also the complete power element can be replaced. For a total revision of the valve a renewal kit can be ordered.

For type numbers of replacement power elements, renewal kits and diaphragm kits see valve selection table.

If a replacement is ordered a "repair parts and service instruction" sheet will be included in which a step by step description is given to disassemble/assemble the valve.

Bulb

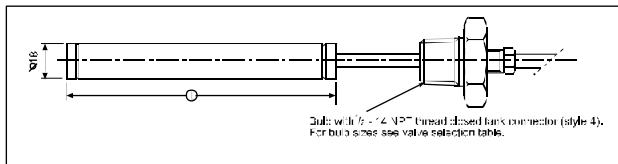

Note:

To provide satisfactory operation, always install valve with bellows down and spring cage up. Capillary end of temperature bulb should always be higher than plugged-end of bulb, or if horizontal, the word TOP (marked on the surface of the sensor) should be at the top or uppermost surface of bulb.

Bulb Wells

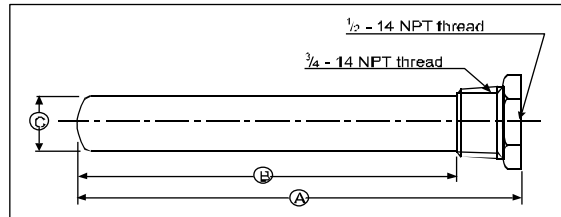

Note:
Never subject temperature bulb to temperatures in excess of 11°C above maximum range temperature. E.g. for range 24 to 57°C the maximum bulb temperature not to exceed 68°C.

Part Number	Dimensions (mm)			Material	
	A	B	C	Connect	Tube
WEL17A-600	285	265	21	Steel	Copper
WEL17A-601	240	220	21	Steel	Copper
WEL18A-602	110	90	21	Steel	Brass

Renewal KITS

Each KIT contains parts as indicated in the table below. The complete KIT must be ordered that contains part required.		Disc cup	Valve disc	Plunger disc	Seat guide	Disc stud	Valve stem	Valve disc holder	Extension sleeve	Valve seat	Diaphragms	Gasket	Valve seat wrench	Screw	Seal ring
V47AA	STT002N600R	1	1	-	1	1	1	-	-	1	4	1	1	-	1
V47AB	STT003N600R	1	1	-	1	1	1	-	-	1	4	1	1	-	1
V47AC	STT004N600R	1	1	-	1	1	1	-	-	1	4	1	1	-	1
V47AD	STT17A609R	1	1	-	1	1	1	-	-	1	5	1	1	-	1
V47AE	STT17A610R	1	1	-	1	1	1	-	-	1	5	1	1	-	1
V47AR	STT17A610R	1	1	-	1	1	1	-	-	1	5	1	1	-	1
V47AS	STT18A600R	-	1	1	-	-	-	1	1	1	5	1	-	1	1
V47AT	STT18A601R	-	1	1	-	-	-	1	1	1	5	1	-	1	1
V47BB	STT15A603R	1	1	-	1	1	1	-	-	1	4	-	1	-	-
V47BC	STT17A613R	1	1	-	1	1	1	-	-	1	4	-	1	-	-
V47BD	STT17A611R	1	1	-	1	1	1	-	-	1	5	-	1	-	-
V47BE	STT17A612R	1	1	-	1	1	1	-	-	1	5	-	1	-	-
V47BR	STT17A612R	1	1	-	1	1	1	-	-	1	5	-	1	-	-
V47BS	STT18A602R	-	1	1	-	-	-	1	1	1	5	-	-	1	-

Dimensions (mm)

Angled type

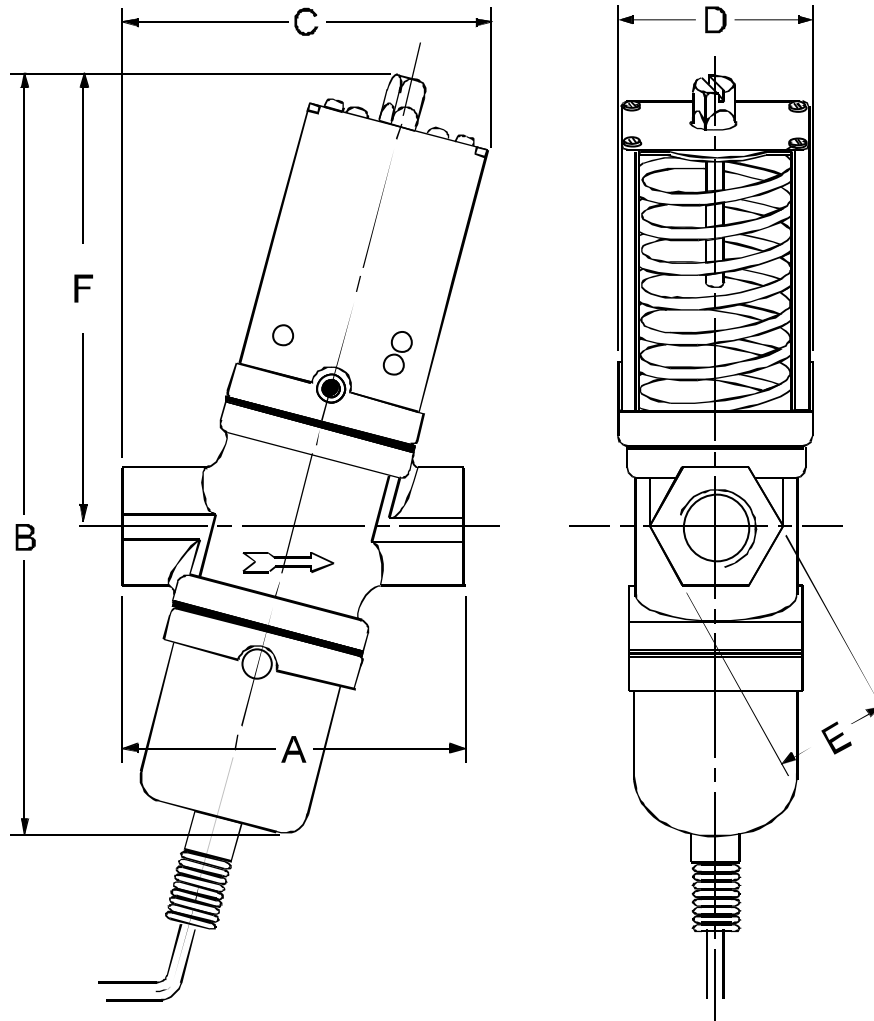

Commercial Types

Valve type	Valve size	Dimensions in mm					
		A	B	C	D	E	F
V47AA	3/8"	69	153	66	43	18	89
V47AB	1/2"	80	170	86	51	27	100
V47AC	3/4"	91	183	95	55	36	110

Dimensions (mm)

Straight type

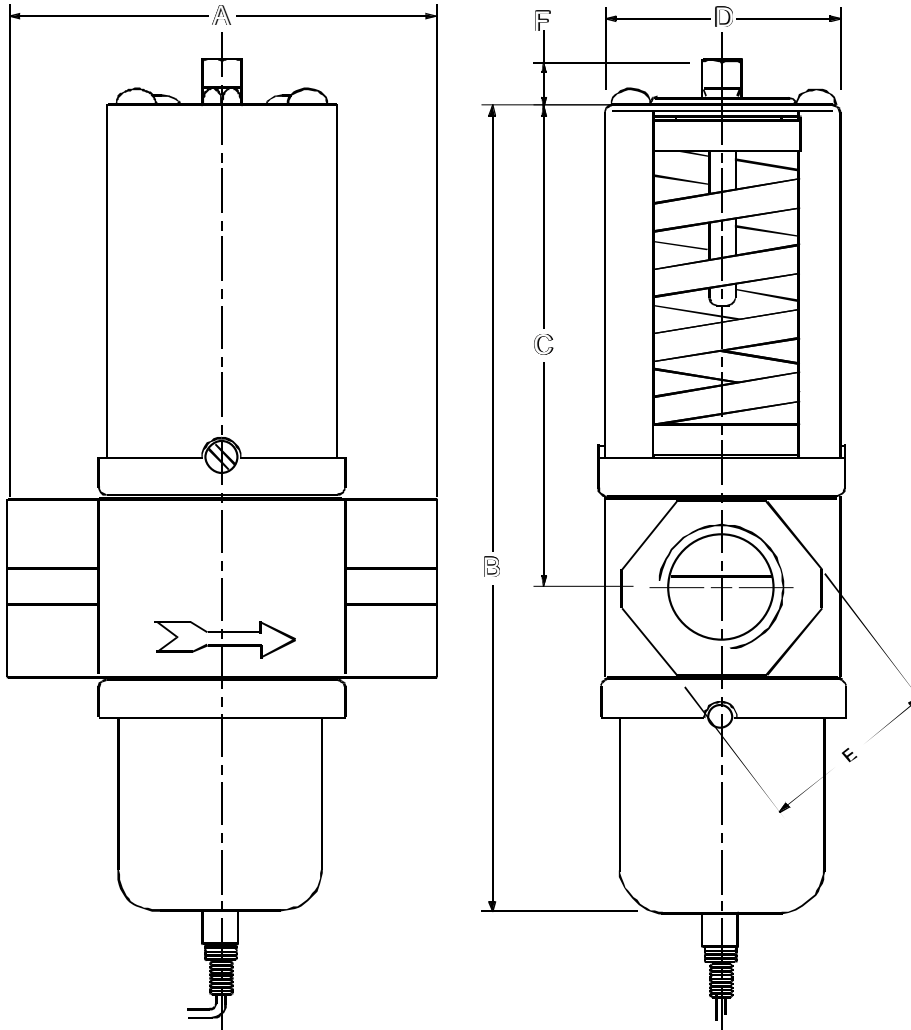

Commercial Types

Valve type	Valve size	Dimensions in mm.					
		A	B	C	D	E	F
V47AD	1"	124	233	139	72	50	13
V47AE	1 1/4"	125	243	145	72	58	13

Sea-water Types

V47BB	1/2"	79	165	86	52	29	10
V47BC	3/4"	86	175	96	55	35	10
V47BD	1"	124	246	139	71	52	13
V47BE	1 1/4"	124	254	144	71	62	13

Dimensions (mm)

Flange type

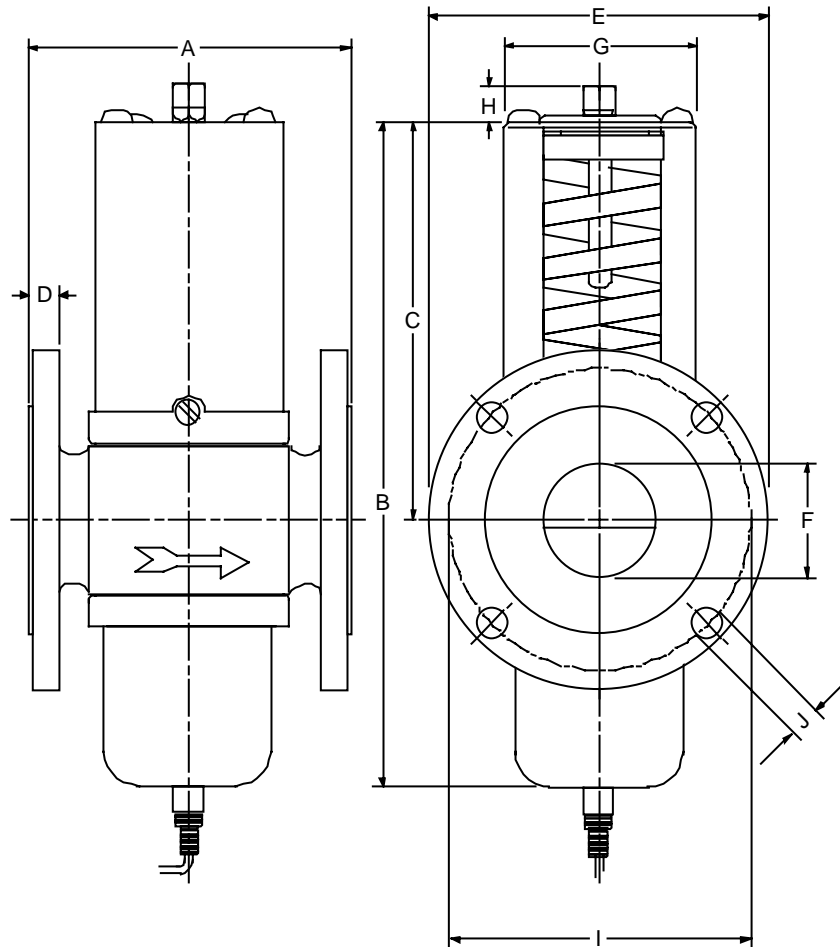

Commercial Types

Valve type	Valve size	Dimensions in mm.									
		A	B	C	D	E	F	G	H	I	J
V47AR	1 1/2"	137	244	144	18	150	47	67	13	110	18
V47AS	2"	168	304	164	20	165	57	90	18	125	18
V47AT	2 1/2"	172	304	164	20	185	70	90	18	145	18

Sea-water Types

V47BR	1 1/2"	135	244	144	14	150	47	67	13	110	18
V47BS	2"	162	304	164	16	165	57	90	18	125	18
V47BT	2 1/2"	172	304	164	16	185	70	90	18	145	18

Valve selection table

Commercial types

Item	Size inch	Range °C	Bulb Size mm	Max. Bulb Temp. °C	Connection body	Replacements			Weight single pack kg.	Bulb Well Order separately
						power element	renewal kit	diaphragm kit		
V47AA-9160	3/8	24/57	ø18 x 83	68	ISO 228 - G3/8	SET98A632R	STT002N600R	KIT016N600 (100)	1,40	WEL18A-602
V47AA-9161	3/8	46/82	ø18 x 83	93	ISO 228 - G3/8	SET98A636R	STT002N600R	KIT016N600 (100)	1,40	WEL18A-602
V47AB-9160	1/2	24/57	ø18 x 83	68	ISO 228 - G1/2	SET98A617R	STT003N600R	KIT016N601 (100)	2,00	WEL18A-602
V47AB-9161	1/2	46/82	ø18 x 83	93	ISO 228 - G1/2	SET98A640R	STT003N600R	KIT016N601 (100)	2,00	WEL18A-602
V47AC-9160	3/4	24/57	ø18 x 83	68	ISO 228 - G3/4	SET98A624R	STT004N600R	KIT016N602 (100)	2,60	WEL18A-602
V47AC-9161	3/4	46/82	ø18 x 83	93	ISO 228 - G3/4	SET98A641R	STT004N600R	KIT016N602 (100)	2,60	WEL18A-602
V47AD-9160	1	24/57	ø18 x 152	68	ISO 7 - Rc 1	SET29A648R	STT17A609R	KIT016N603 (50)	4,50	WEL17A-601
V47AD-9161	1	46/82	ø18 x 152	93	ISO 7 - Rc 1	SET29A629R	STT17A609R	KIT016N603 (50)	4,50	WEL17A-601
V47AE-9160	1 1/4	24/57	ø18 x 152	68	ISO 7 - Rc 1 1/4	SET29A648R	STT17A610R	KIT016N603 (50)	5,50	WEL17A-601
V47AE-9161	1 1/4	46/82	ø18 x 152	93	ISO 7 - Rc 1 1/4	SET29A629R	STT17A610R	KIT016N603 (50)	5,50	WEL17A-601
V47AR-9160	1 1/2	24/57	ø18 x 152	68	Flange 1 1/2 DIN2533	SET29A648R	STT17A610R	KIT016N603 (50)	8,00	WEL17A-601
V47AR-9161	1 1/2	46/82	ø18 x 152	93	Flange 1 1/2 DIN2533	SET29A629R	STT17A610R	KIT016N603 (50)	8,00	WEL17A-601
V47AS-9160	2	24/46	ø18 x 254	57	Flange 2 DIN2533	SET29A662R	STT18A600R	KIT016N604 (25)	12,30	WEL17A-600
V47AS-9161	2	46/71	ø18 x 254	82	Flange 2 DIN2533	SET29A-632R	STT18A600R	KIT016N604 (25)	12,30	WEL17A-600
V47AT-9160	2 1/2	24/46	ø18 x 254	57	Flange 2 1/2 DIN2533	SET29A662R	STT18A601R	KIT016N604 (25)	15,00	WEL17A-600
V47AT-9161	2 1/2	46/71	ø18 x 254	82	Flange 2 1/2 DIN2533	SET29A-632R	STT18A601R	KIT016N604 (25)	15,00	WEL17A-600

Sea-water types

Item	Size inch	Range °C	Bulb Size mm	Max. Bulb Temp. °C	Connection body	Replacements			Weight single pack kg.	Bulb Well Order separately
						power element	renewal kit	diaphragm kit		
V47BB-9161	1/2	46/82	ø18 x 83	93	ISO 228 - G1/2	SET98A640R	STT15A603R	KIT016N601 (100)	2,00	WEL18A-602
V47BC-9160	3/4	24/57	ø18 x 83	68	ISO 228 - G3/4	SET98A624R	STT17A613R	KIT016N602 (100)	2,60	WEL18A-602
V47BC-9161	3/4	46/82	ø18 x 83	93	ISO 228 - G3/4	SET98A641R	STT17A613R	KIT016N602 (100)	2,60	WEL18A-602
V47BD-9160	1	24/57	ø18 x 152	68	ISO 228 - G1	SET29A648R	STT17A611R	KIT016N603 (50)	4,50	WEL17A-601
V47BD-9161	1	46/82	ø18 x 152	93	ISO 228 - G1	SET29A629R	STT17A611R	KIT016N603 (50)	4,50	WEL17A-601
V47BE-9160	1 1/4	24/57	ø18 x 152	68	ISO 228 - G1 1/4	SET29A648R	STT17A612R	KIT016N603 (50)	5,50	WEL17A-601
V47BR-9160	1 1/2	24/57	ø18 x 152	68	Flange 1 1/2 DIN86021	SET29A648R	STT17A612R	KIT016N603 (50)	9,00	WEL17A-601
V47BS-9161	2	46/71	ø18 x 254	82	Flange 2 DIN86021	SET29A-632R	STT18A602R	KIT016N604 (25)	14,00	WEL17A-600

Specifications

Commercial

	Size	3/8" - 3/4"	1" - 1 1/4"	1 1/2" - 2 1/2"
Max. water supply press. (bar)		10	10	10
Max. water supply temp.		90 °C	90 °C	90 °C
Min. water supply temp.*		-20 °C	-20 °C	-20 °C
Valve body style	angled	x		
	straight		x	x
Pipe connection**	thread ISO 228	x		
	thread ISO 7 - Rc		x	
	flange DIN 2533			x
Capillary length (m)		1.8 plain	1.8 armored	1.8 armored
Material	body	hot forged brass	cast iron***	cast iron***
	disc stud/disc cup	brass	brass	brass
	seat	alum. bronze	alum. bronze	alum. bronze
	diaphragms	BUNA-N	BUNA-N	BUNA-N
	bulb	copper	copper	copper
Closed tank connector		brass	brass	brass
stem/extension sleeve		brass	brass	brass
	disc	BUNA-N	BUNA-N	BUNA-N

Sea-water

	Size	3/8" - 3/4"	1" - 1 1/4"	1 1/2" - 2 1/2"
Max. water supply press. (bar)		10	10	10
Max. water supply temp.		90 °C	90 °C	90 °C
Min. water supply temp.*		-20 °C	-20 °C	-20 °C
Valve body style	straight	x	x	x
Pipe connection**	thread ISO 228	x	x	
	flange DIN86021			x
Capillary length (m)		1.8 plain	1.8 armored	1.8 armored
Material	body	bronze	bronze	bronze
	disc stud/disc cup	monel	monel	monel
	seat	monel	monel	monel
	diaphragms	BUNA-N	BUNA-N	BUNA-N
	bulb	copper	copper	copper
Closed tank connector		brass	brass	brass
stem/extension sleeve		monel	monel	monel
	disc	BUNA-N	BUNA-N	BUNA-N

- * Care should be taken the valve does not freeze up.
 ** Thread ISO 7 - Rc = DIN2999-RC thread/ISO 228 = DIN259-Rp thread
 *** Cast iron bodies are executed with rust resisting finish

The performance specifications are nominal and conform to acceptable industry standards. For application at conditions beyond these specifications, consult the local Johnson Controls office. Johnson Controls, Inc. shall not be liable for damages resulting from misapplication or misuse of its products.



Johnson Controls International, Inc.

Headquarters: Milwaukee, Wisconsin, USA
 European Customer Service Center: Westendhof 3, D-45143 Essen, Germany
 European Factories: Essen (Germany), Leeuwarden (The Netherlands) and Lomagna (Italy)
 Branch Offices: Principal European Cities.
 This document is subject to change

www.johnsoncontrols.com
 Printed in Europe

Series V48

3-way Pressure Actuated Modulating Valves

Introduction

These watervalves are especially designed for condensing units cooled either by atmospheric or forced draft cooling towers. They may be used on single, or multiple condenser hook-ups to the tower. The type V48 valve senses the compressor head pressure and allows cooling water to flow to the condenser, to by-pass the condenser, or to allow waterflow to both condenser and by-pass line in order to maintain correct refrigerant head pressure. A further advantage of this system is that the 3-way valve permits a continuous water flow to the tower so the tower can operate efficiently with a minimum of maintenance on nozzles and wetting surfaces. The valves can be used in non-corrosive refrigerant systems. Ammonia power elements and valves designed for salt-water applications are available. The valves have a quick opening characteristic.



**Series V48
Pressure Actuated Three-way Valve**

Feature and Benefits

<input type="checkbox"/> Pressure balanced design	The valve setpoint and performance are independent of liquid inlet pressure. Valve can withstand severe hydraulic shock-waves without damage.
<input type="checkbox"/> Free movement of all parts	Provides smooth pressure modulation.
<input type="checkbox"/> Easy manual flushing	Does not affect valve adjustment.
<input type="checkbox"/> High Kv values	Small dimensions with very high capacity
<input type="checkbox"/> Pressure actuated	Direct and fast response to pressure variations
<input type="checkbox"/> Can be used as mixing or diverting valve	Reduces stock. One type for different applications.

Note

All series V48 water regulating valves are designed for use only as operating devices. Where system closure, improper flow or loss of pressure due to valve failure can result in personal injury and/or loss of property, the user must add a separate safety device.

Description

A pressure-balanced design employing rubber sealing diaphragms correctly proportioned to the valve port area, balances valve against both gradual and sudden water pressure changes, and seals water away from range spring, guides, and sliding parts so these are not submerged in water where they would be subject to sedimentation and corrosion.

Adjustment

The pressure at which the valve starts to open (= opening point port 1 to port 2) can be adjusted by the adjusting screw located at the top of the range spring housing. Valves may be adjusted with standard service valve wrenches or screwdrivers. (Valves are not factory set at a certain value.)

Manual flushing

Valves may be manually flushed by lifting the lower spring guide with screwdrivers at two sides of the pressure plate to open valve. This does not affect valve adjustment.

Installation

At a certain (adjustable) pressure, port 1 to port 2 starts to open, while port 1 to port 3 starts to close. This so called "opening point" is adjustable with the screw on the top of the spring housing and results in an equal amount change in both condenser and by-pass settings.

Valve size selection

The valve size is determined by three data:

- The required maximum flow (quantity of liquid = Q) that must pass the valve (in m³/h).
- The maximum allowed pressure drop (= ΔP) across the valve (in bar).
- The head pressure rise (= HPR) which is the difference between the pressure where port 1 to port 2 starts to open and the condenser operating pressure.

Note

At a certain pressure port 1 to port 2 starts to open. If the pressure decreases, it will close again at a $\approx 0,5$ bar lower pressure than the pressure where it starts to open.

The valve size can be selected by the use of:

- the diagrams on pages 4 and 5.
- k_V factors and calculation formulae (see page 3). This can only be used when the allowed head pressure rise is ≥ 2 bar for 1.5/7.5 bar range valves and ≥ 3 bar for 4/16, 4/20 and 6/20 bar range valves. At lower head pressure rises the diagram has to be used.

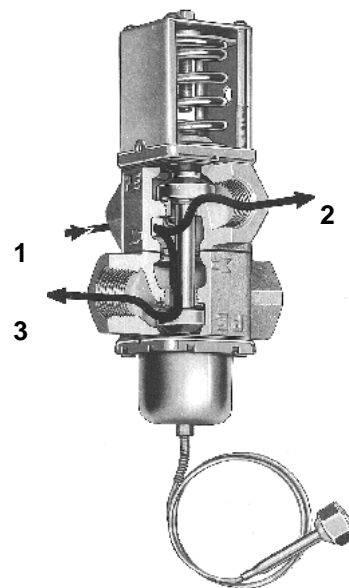
Cut-away section V48

- 1 From cooling system
- 2 To condenser
- 3 By-pass

Fig. 1

Valve size selection by the use of the diagrams pages 4 and 5

Q: The quantity of water (m³/h) is indicated on the left side of the upper diagram (= scale A).

Δ P: The curves for the pressure drop across the valve are indicated in the lower diagram (0,25 up to 1 bar, see scale C).

HPR: The head pressure rise above the valve opening point is indicated in the lower part of the diagrams on pages 4 and 5 (see scale B).

Note

On page 4 there are two vertical head pressure rise scales. The left side for low range (1.5/7.5 bar) valves and the right side for high range (4/16 bar) valves. On page 5 for range 4/20 and 6/20 bar valves.

Valve size:

The valve size can be read from the right side of the upper diagram.

Valve size selection example (see page 4):

Q = 5.1 m³/h
HPR = 3.2 bar
Δ P = 0.5 bar
Refrigerant = R22
Valve range = 4/16 bar

- Draw a horizontal line through the 5.1 m³/h point of scale A (see A).
- Draw a horizontal line through the 3.2 bar of scale B (see B). The intersection of this horizontal line with the delta P curve of 0.5 bar is used to draw a vertical line from this intersection point up to the horizontal line in scale A (see C).
- The intersection point of this vertical line with the horizontal line in scale A indicates the valve size. If the point falls on a size curve, this is the valve size needed. If it is between two sizes always take the largest valve size. In this example it is between size 3/4" and 1". The selected valve is 1".

Of course the same diagram can be used to read the pressure drop across a valve or to find the maximum capacity of a valve.

E.g. Pressure drop.

Q needed is 6 m³/h.
HPR is 2.5 bar.
The valve size available is 1".
What will be the pressure drop?

Solution:

- Draw a horizontal line through 6 m³/h (scale A) and determine the intersection of this line with the 1" valve curve.
- Draw a vertical line from this intersection point to the 2.5 bar HPR line.
- The found part is between the 0.5 and 0.75 bar pressure drop curves. Interpolate the point which gives 0.7 bar.

If this is acceptable the valve can be used.

E.g. Maximum flow.

Valve size is 1"
HPR = 3 bar
Maximum Δ P = 0.25 bar
What is maximum Q?

Solution:

- Draw a horizontal line at 3 bar HPR (scale B) till intersection with 0.25 bar delta P curve.
- Draw a vertical line from this intersection point to the 1" valve curve.
- Draw from this point a horizontal line to the water flow scale A.
You find 4.0 m³/h

Valve size selection by the use of the K_v factors and calculation formulae

For water:

The following K_v values can be used:

$$K_v = \frac{Q}{\sqrt{\Delta p}}$$

Valve size	K _v value
------------	----------------------

$$\Delta P = \left(\frac{Q}{K_v} \right)^2$$

1/2"	2.3
3/4"	4.7
1"	8.0
1 1/4"	10.2
1 1/2"	16.5

$$Q = K_v \cdot \sqrt{\Delta p}$$

Q = quantity of liquid (in m³/h)
Δ P = pressure drop across valve (in bar)
K_v = valve flow coefficient

The Kv factor is the quantity of 20°C water that will pass through the valve at one bar pressure drop (port 1 to port 2) and a valve opening which belongs by 2.2 bar (for low range valves) or 3 bar (for high range valves) head pressure rise (HPR) above the valve opening point.

Diagram for selecting the valve size corresponding with information on page 2 and 3

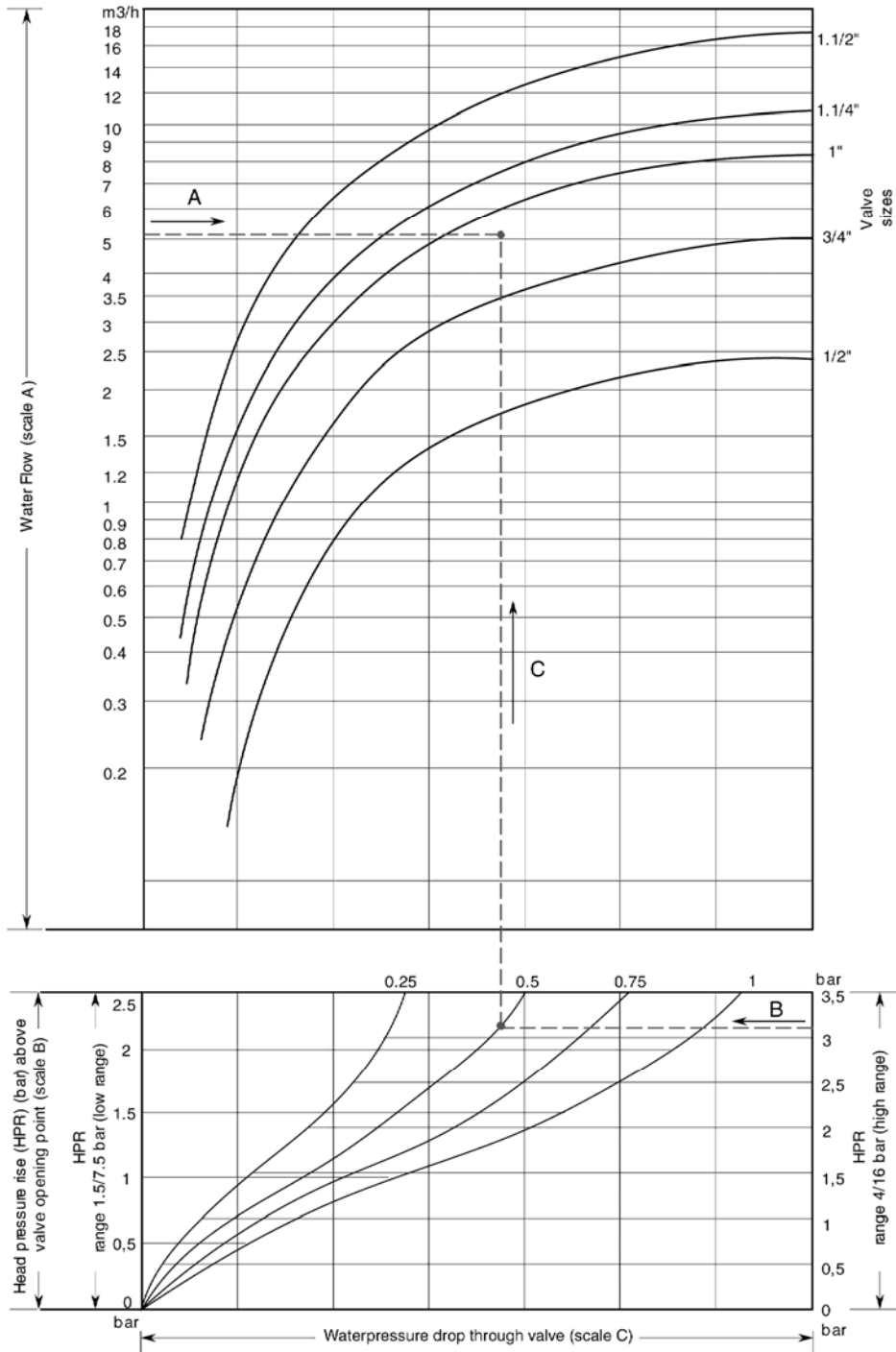

Note: 1 dm³/s = 3.6 m³/h = 15.8 U.S. gal./min. = 13.2 U.K. gal./min.

1 bar = 100 kPa = 0.1 MPa ≈ 1.02 kp/cm² = 1.02 at ≈ 14.5 psi.

Fig. 2a

Diagram for selecting the valve size corresponding with information on page 2 and 3

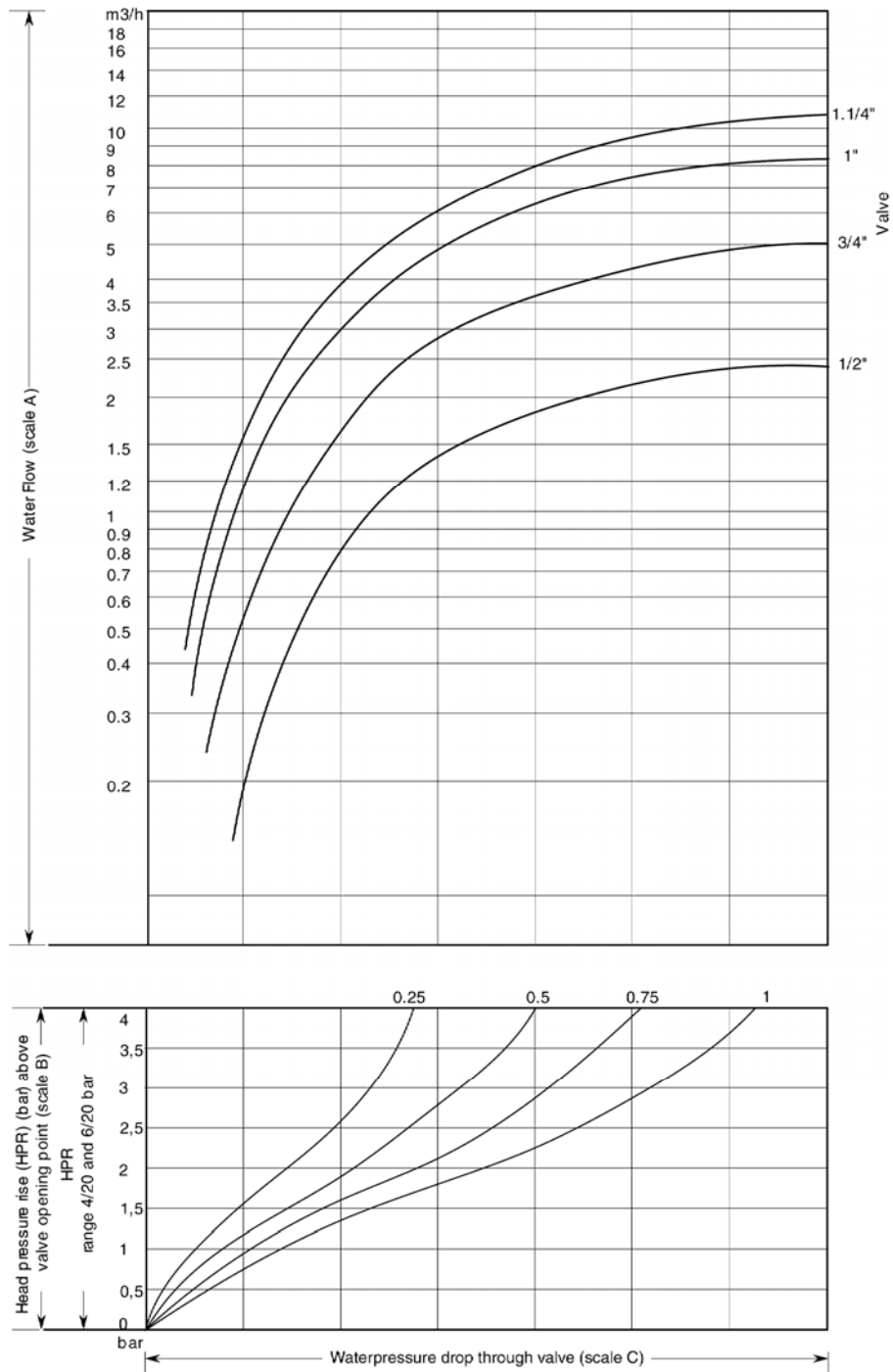

Fig.2b

Ammonia (NH₃) applications

For all larger valve types an ammonia element is available. These elements have style 15 pressure connection and consist of a stainless steel bellow in a steel cup (coated). The existing element can be replaced by this ammonia element. The pressure range does not change. For the high range valves the spring inside the power element has to be placed in the ammonia element. If low-pressure range is needed this spring can be removed. For low quantities you have to order the selected valve and separate ammonia replacement power element (see valve type selection table). For quantity orders a special valve type can be set up. Then please contact the JC sales office in your region.

Repair and replacement

Diaphragm kits can be ordered for all valves. Also the complete power element can be replaced. For a total revision of the valve a renewal kit can be ordered. For type numbers of replacement power elements, renewal kits and diaphragm kits see valve selection table.

If a replacement is ordered a "repair parts and service instruction" sheet will be included in which a step by step description is given to disassemble/assemble the valve.

Renewal KITs

Each KIT contains parts as indicated in the table below. The complete KIT must be ordered that contains part required.		Disc cup	Valve disc	Valve spacer	Seat guide	Disc stud	Valve stem	Valve seat	Diaphragms	Gasket	Valve seat wrench	Screw	Seal ring	O-ring	Lock-washer
Valve type	KIT number														
V48AB	STT15A605R	2	2	-	1	2	1	2	4	2	1	-	1	-	-
V48AC	STT16A604R	2	2	-	1	2	1	2	4	2	1	-	1	-	-
V48AD	STT17A616R	2	2	-	1	2	1	2	6	1	1	-	1	1	-
V48AE	STT17A617R	2	2	-	1	2	1	2	6	1	1	-	1	1	-
V48AF	STT17A604R	-	1	2	-	-	-	2	6	1	-	1	1	2	1
V48BC	STT16A605R	2	2	-	-	2	1	2	4	2	1	-	-	-	-

Type number selection table and replacement parts

Commercial types

Item	Size inch	Range bar	Refrig. connec.	Capil. length	Connection thread	Weight single pack kg.	Quantity per box	Weight per box kg.
V48AB-9510	1/2	4 / 20	style 50	0.75	ISO 228 - G ¹ / ₂	2.3	1	2.3
V48AB-9600	1/2	4 / 16	style 13	0.75	ISO 228 - G ¹ / ₂	2.3	1	2.3
V48AB-9601	1/2	1.5/ 7.5	style 13	0.75	ISO 228 - G ¹ / ₂	2.3	1	2.3
V48AC-9510	3/4	4 / 20	style 50	0.75	ISO 228 - G ³ / ₄	3.0	1	3.0
V48AC-9600	3/4	4 / 16	style 13	0.75	ISO 228 - G ³ / ₄	3.0	1	3.0
V48AC-9601	3/4	1.5/ 7.5	style 13	0.75	ISO 228 - G ³ / ₄	3.0	1	3.0
V48AD-9510	1	6 / 20	style 50	0.75	ISO 7 - Rc1	5.5	1	5.5
V48AD-9600	1	4 / 16	style 13	0.75	ISO 7 - Rc1	5.5	1	5.5
V48AD-9601	1	1.5/ 7.5	style 13	0.75	ISO 7 - Rc1	5.5	1	5.5
V48AE-9510	1 ¹ / ₄	6 / 20	style 50	0.75	ISO 7 - Rc1 ¹ / ₄	7.5	1	7.5
V48AE-9600	1 ¹ / ₄	4 / 16	style 13	0.75	ISO 7 - Rc1 ¹ / ₄	7.5	1	7.5
V48AE-9601	1 ¹ / ₄	1.5/ 7.5	style 13	0.75	ISO 7 - Rc1 ¹ / ₄	7.5	1	7.5
V48AF-9300	1 ¹ / ₂	6 / 14	style 5	-	ISO 7 - Rc1 ¹ / ₂	11.5	1	11.5
V48AF-9301	1 ¹ / ₂	1.5/ 9	style 5	-	ISO 7 - Rc1 ¹ / ₂	11.5	1	11.5

Item	Replacements			Ammonia element type
	power elem.	renewal kit	diaphragm kit	
V48AB-9510	Not available	STT15A605R	KIT016N601 (100)	Not available
V48AB-9600	246-824R	STT15A605R	KIT016N601 (100)	Not available
V48AB-9601	246-824R	STT15A605R	KIT016N601 (100)	Not available
V48AC-9510	Not available	STT16A604R	KIT016N602 (100)	Not available
V48AC-9600	246-825R	STT16A604R	KIT016N602 (100)	Not available
V48AC-9601	246-825R	STT16A604R	KIT016N602 (100)	Not available
V48AD-9510	Not available	STT17A616R	KIT016N603 (50)	246-667R
V48AD-9600	246-925R	STT17A616R	KIT016N603 (50)	246-667R
V48AD-9601	246-925R	STT17A616R	KIT016N603 (50)	246-667R
V48AE-9510	Not available	STT17A617R	KIT016N603 (50)	246-667R
V48AE-9600	246-925R	STT17A617R	KIT016N603 (50)	246-667R
V48AE-9601	246-925R	STT17A617R	KIT016N603 (50)	246-667R
V48AF-9300	246-758R	STT17A604R	KIT016N604 (25)	246-781R
V48AF-9301	246-671R	STT17A604R	KIT016N604 (25)	246-781R

Sea-water types

Item	Size inch	Range bar	Refrig. connec.	Capil. length	Connection thread	Weight single pack kg.	Quantity per box	Weight per box kg.
V48BC-9600	3/4	4 / 16	13	0.75	ISO 228 - G ³ / ₄	3.0	1	3.0

Item	Replacements			Ammonia element type
	power elem.	renewal kit	diaphragm kit	
V48BC-9600	246-825R	STT16A605R	KIT016N602 (100)	Not available

Pressure connections

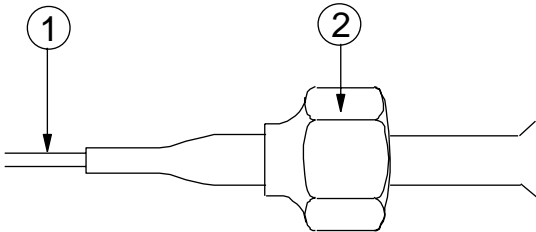

Fig. 3

Style 13 (excl. valve depressor)

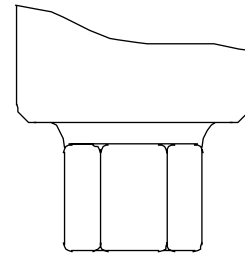

Fig. 5

Style 15 1/4-18NPT (female)

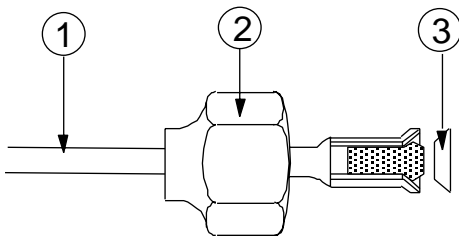

Fig. 4

Style 50 (incl. valve depressor mounted into machined flare)

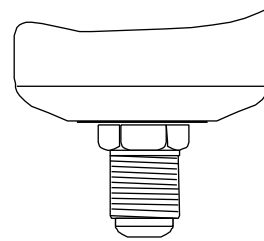

Fig. 6

Style 5 7/16-20 UNF

1. 75 cm capillary.
2. 7/16 - 20 UNF flare nut.
3. copper sealing

Dimensions (mm)

For valve type see specifications page 11

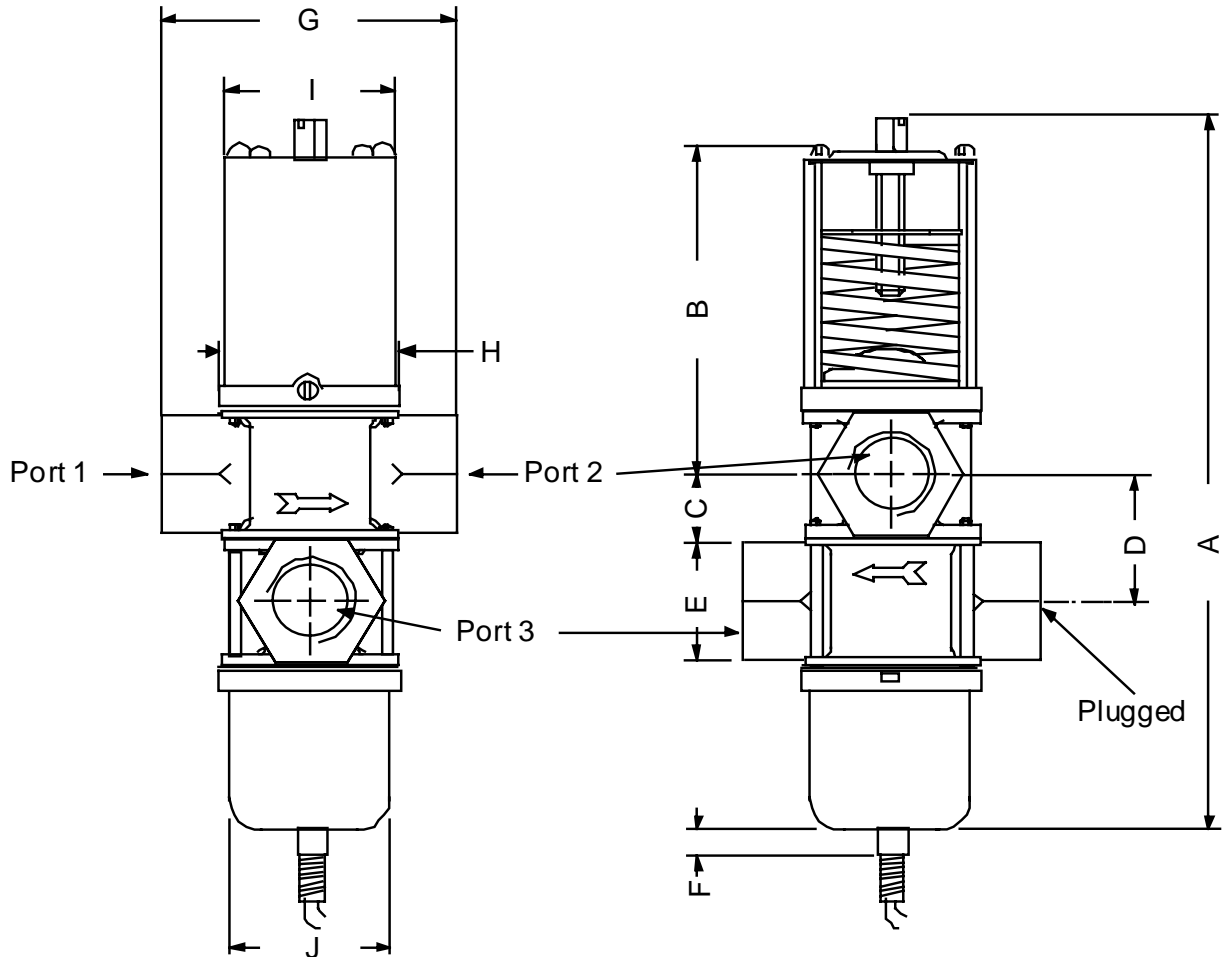

Commercial Types

Valve type	Valve size	A mm	B mm	C mm	D mm	E mm	F mm	G mm	H mm	I mm	J mm
V48AB	1/2"	192	91	19	41	30	8	82	52	48	52
V48AC	3/4"	208	100	23	45	36	8	88	56	52	56
V48AD	1"	287	142	25	51	50	8	124	71	67	72
V48AE	1 1/4"	296	141	31	61	58	8	127	71	67	71

Sea-water Types

V48BC	3/4"	203	97	22	45	35	9	95	55	52	55
-------	------	-----	----	----	----	----	---	----	----	----	----

Size 1/2" - 1 1/4"

Fig. 7

Dimensions (mm)

For valve type see specifications page 11

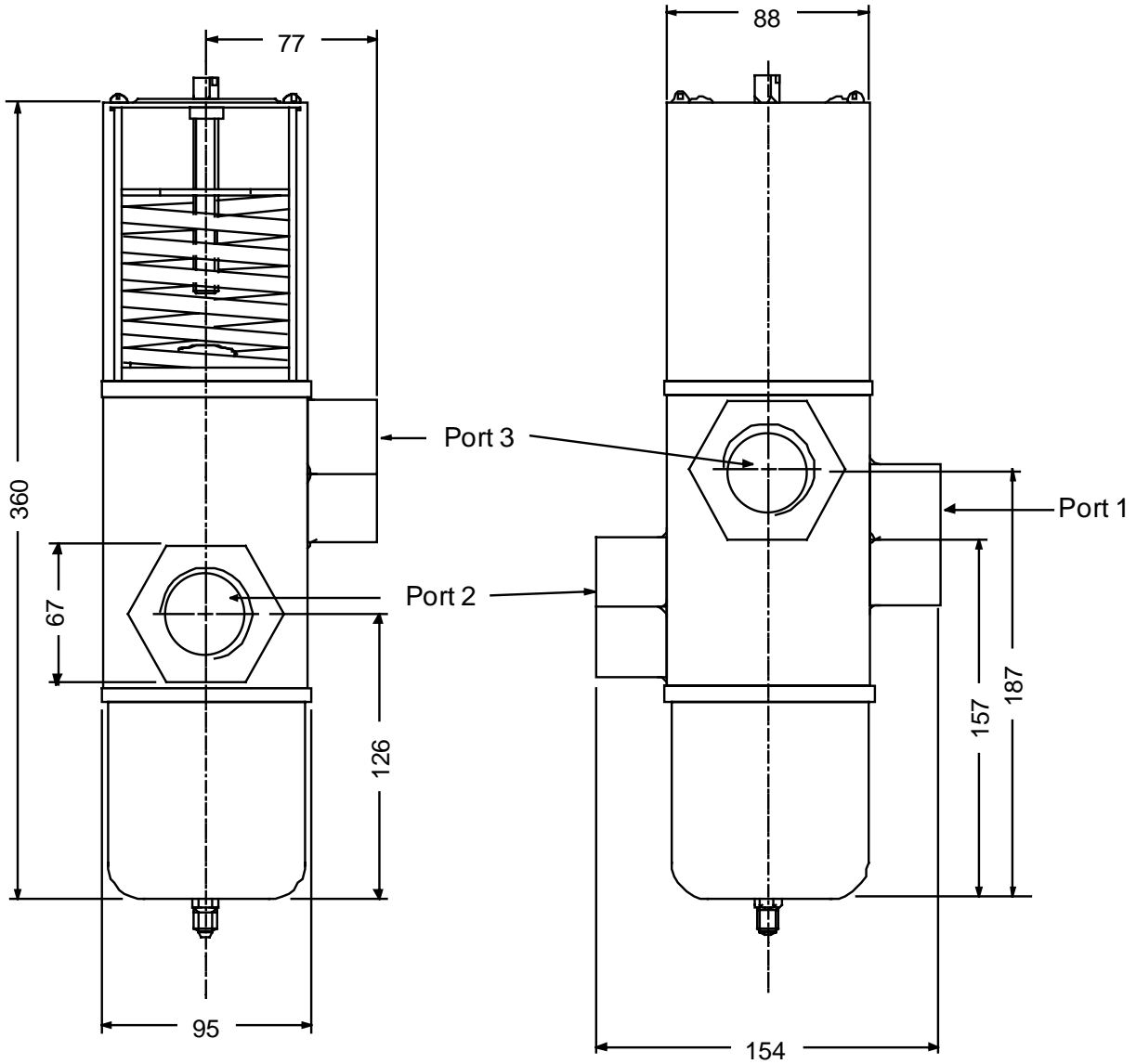

V48AF

Size 1 1/2"
Fig. 8

Specifications

	Commercial				Sea-water
	Size	1/2" - 3/4"	1" - 1 1/4"	1 1/2"	1 1/2"
Operating range (bar)	1.5-7.5 4-16 4-20	1.5-7.5 4-16 6-20	1.5-9	6-14	4-16
Max. refrig. overrun press. (bar)	28	28	28	28	28
Max. water supply press. (bar)	10	10	10	10	10
Max. water supply temp.	90 °C	90 °C	90 °C	90 °C	90 °C
Min. water supply temp. *	-20 °C	-20 °C	-20 °C	-20 °C	-20 °C
Valve hysteresis (bar)	~ 0.5	~ 0.5	~ 0.5	~ 0.5	~ 0.5
Pipe ** thread ISO 228	x				x
connection thread ISO 7 - Rc		x	x	x	
Material body	brass	cast iron***	cast iron***	cast iron***	bronze
disc stud/disc cup	brass	brass	brass	brass	monel
seat	alum. bronze	alum. bronze	alum. bronze	alum. bronze	monel
diaphragms	BUNA-N	BUNA-N	BUNA-N	BUNA-N	BUNA-N
bellows	ph. bronze	ph. bronze	tombac	monel	ph. bronze
stem/spacers	brass	brass	brass	brass	monel
disc	BUNA-N	BUNA-N	DURONZE	DURONZE	BUNA-N
Pressure connection style	See selection table.				
Capillary length	See selection table.				
Ammonia element style 15 press. connection	Stainless steel bellow in steel cup.				
Shipping weights	See valve selection table.				

* Care should be taken the valve does not freeze up.

** Thread ISO 7 - Rc = DIN2999-RC thread / ISO 228 = DIN259-Rp thread

*** Cast iron bodies are executed with rust resisting finish

The performance specifications are nominal and conform to acceptable industry standards. For application at conditions beyond these specifications, consult the local Johnson Controls office. Johnson Controls, Inc. shall not be liable for damages resulting from misapplication or misuse of its products.



Johnson Controls International, Inc.

Headquarters: Milwaukee, WI, USA
 European Headquarters: Brussels, Belgium
 European Factories: Lomagna (Italy), Leeuwarden (The Netherlands) and Essen (Germany)
 Branch Offices: Principal European Cities.

This document is subject to change

www.johnsoncontrols.com
 Printed in Europe